



2023 RESEARCH SUMMARY

PRECISION TECHNOLOGY INSTITUTE
PONTIAC, IL



2023 PTI Farm Research Summary

Table of Contents:

Introduction and Guide to Summary Report	5
Corn Summary of 2023 FurrowJet® Applications	128
Corn Summary of 2023 Conceal® Applications	142
Soybeans Table of Contents	179
Soybeans Summary of 2023 FurrowJet® & Conceal® Application	242
Wrap Up	262-264
Acknowledgments and Legal Statement	265

Corn Planting Principles:

Planting Date	6
Starter Fertilizer Response by Date	7-8
vSet® Planter Singulation	9
SmartDepth® Planting Depth	10-12
Keeton® Seed Firmer	13
Reveal® Residue Management	14-15
Multi-Year Day of Emergence	16
High Speed Planting	17
SeedTube Planting	18
Closing Wheel/Tillage	19-23
Caselh FurrowForce® Retrofit	24
Downforce Management	25-27
Planter "All-Wrong"	28
Multi-Genetic Planting	29-30
Leaf Orientation	31
Corn Directional Planting	32
15" Row Corn Seeding Rate	33-34
20" Row Corn Seeding Rate	35-36
Multi-Year Row Width Corn	37
30" vs 20" Row Short Corn	39-40
REVLIN® HOPPER THROTTLE™	41-42
Rosen's Stride Bio™ Hopper Box	43
Rootella® F Inoculant	44
TerraMax MicroAZ-ST Dry™ Inoculant	45
Terrasym® 450 + Dust™ Hopper Box	46
Hopper Box CRW Mitigation	47
Corn Strip Planting	145-152

Corn Dry Fertilizer Studies:

Broadcast vs Banding	48-50
Corn Fertilizer Rate Efficiency	51-53
Broadcast vs Banding Rate Efficiency	54-55
Mosaic® Sulfur/Boron Dry Fertilizer	56-57
Liquid vs Dry Fall Strip-Till	58-60
Calcium Products™ 98G™	61
Calcium Products™ SO4™	62
Planter Applied Micro-Nutrient	63-64
AQUASORB	65

Corn Nitrogen Programs:

Narrow Row At-Plant Nitrogen	38
Pivot Bio PROVEN40® Nitrogen Mgt.	110-111
Pivot Bio PROVEN40®OS Nitrogen Mgt.	112-113
Envita® Nitrogen Mgt.	114-116
Source™ Foliar V4 Application	117
Source™ Foliar VT Application	118
QLF BOOST™ Nitrogen Inclusion	119-120
At-Plant Conceal® vs. Weed-N-Feed	129
Single vs. Dual Band Conceal® Nitrogen	130
Nitrogen Rate/Placement	131-133
Nitrogen Sealer	134

Corn FurrowJet® Programs:

Marco QuickGrow™ LTE FurrowJet®	108
Nachurs® imPulse® FurrowJet®	109
Aqua-Yield® NanoCS®	121-122
10-34-0 FurrowJet®	123
Ethos™ XB In-Furrow	124
Xyway® LFR® FurrowJet®	125-126
FurrowJet® Side-Wall	127

Corn Cover Crop Studies:

Continuous Corn Cover Crop	143
Corn after Soybean Cover Crop	144

Corn Conceal® Programs:

At-Plant Conceal® vs. Weed-N-Feed	129
Single vs. Dual Band Conceal® Nitrogen	130
Nitrogen Rate/Placement	131-133
Conceal® K-Fuse® Potassium	135
Aqua-Yield® Nano N+®	136-137
Aqua-Yield® NanoPack®	138-139
PhycoTerra®	140-141

Corn Foliar Programs:

Veltyma® Foliar Fungicide	153
TopGuard® EQ Foliar Fungicide	154
Miravis® Neo Foliar Fungicide	155
Ground vs. UAV Foliar Application	156-157

Aqua-Yield® NanoK®	158-159
Aqua-Yield® NanoPro®	160

Corn Harvest Studies:

Chopping Corn Head	161
Phantom Yield Loss	162-165
On-Farm Drying and Storage	166-173

Corn Tillage Studies:

Corn Tillage	174-176
Summers Variable Rate Tillage	177
Strip-Till Freshener	178

Corn Intensive Management Studies:

High Management NETAFIM® Irrigation	66
NETAFIM® Sub-Surface vs Surface	67-68
Tile Drainage & Sub-Irrigation	69-71
High Management Strip Cropping	72-74
Irresponsible Nitrogen Rate	75-76
High Management AgroLiquid®	77-80
High Management Marco	81-84
High Management Stoller® USA	85-88
Irrigated vs Dryland ROI Analysis	89
Ultra High Management Nachurs®	90-92
High Management Nachurs®	93-94
High Management New Fields/NMS LL	95-98
Organic Corn	99-101
High Management Ocean Blue Ag	102-104
Short Corn Fertility/Plant Height	105-107

Soybean Planting Principles:

Planting Date	180
Multi-Year Early Plant Date	181
Soybean Early Plant Maturity	182
Starter Fertilizer Response by Date	183-184
SmartDepth® Planting Depth	185-187
Reveal® Residue Management	188-190
Downforce Management	191-193
Keeton® Seed Firmer	194
Singulation	195
SeedRight Bundle Drop Singulation	196
High Speed	197
Tillage/Closing Wheels	198-200

Planting Direction	201
REVLIN® HOPPER THROTTLE®	202
Cover Crop Study	203-205
Rolling	243
Strip Cropping	244-249
Strip Cropping System Summary	250
Chopping Corn Head	261

Soybean Dry Fertilizer Studies:

Broadcast vs Banding	206-207
Broadcast vs Banding Rate Efficiency	208-210
Liquid vs Dry Fall Strip-Till	211-213
Calcium Products 98G®	214

Soybean FurrowJet® Programs:

Aqua-Yield® NanoCS®	234-235
Nachurs Triple Option	236
Xyway® LFR®	237-238
Zironar™	239-240
FurrowJet® Side-Wall	241

Soybean Foliar Programs:

Revvytek™ Foliar Fungicide	251
Miravis® Neo™ Foliar Fungicide	252
Ground vs UAV	253-254
Aqua-Yield® NanoPack®	255-256

Soybean Conceal® Programs:

Marco Fertilizer Conceal® 14-12-4-6S	233
--------------------------------------	-----

Soybean Tillage Studies:

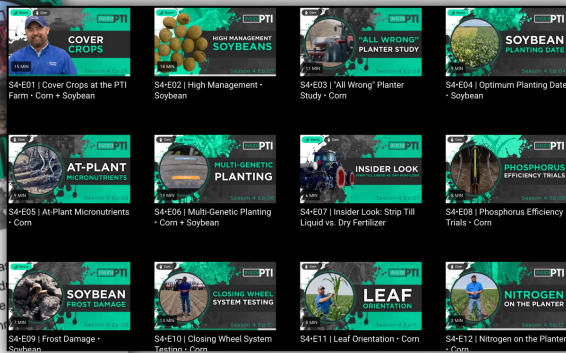
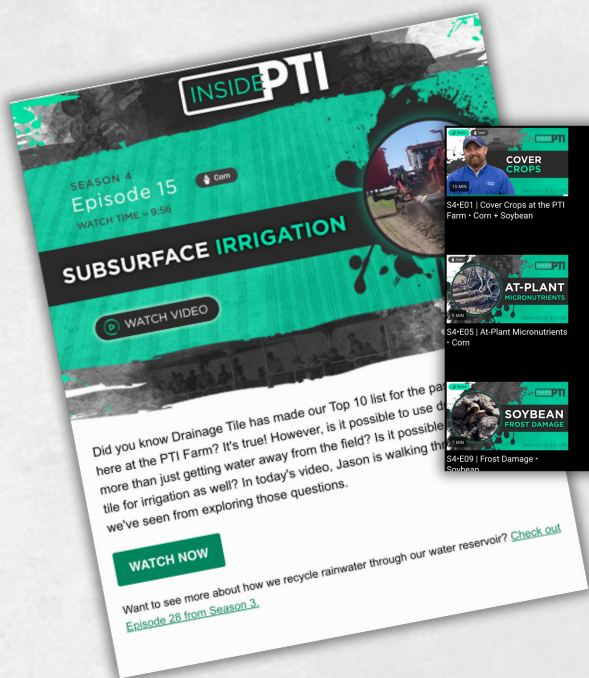
Soybean Tillage	257-259
Pre-Strip Vertical Tillage	260

Soybean Intensive Mgt. Studies:

NETAFIM™ Irrigation Study	215
Soybean Seed Size	216
High Management Nachurs®	217-218
High Management AgroLiquid®	219-222
Irrigated vs Dryland ROI Analysis	223
High Management Marco	224-225
High Management Stoller® USA	226-227
High Management NewFields Ag/ NMS	228-229
High Management Ocean Blue Ag	230-232

INSIDEPTI

Get trial results sent directly to your inbox with added agronomy explanations. The PTI team sends videos via email packed with agronomy insights, exclusive insider info, farm updates, and lessons they've learned at the PTI Farm!



Join
InsidePTI



insidepti.com

Introduction and Guide to Summary Report

Precision Planting is excited to share our 6th year of PTI research farm results and findings. We hope they provide useful insights that help drive thoughtful consideration around future crop management decisions. This publication is intended to summarize and explain the many agronomic trials that were implemented in 2023. This year we added new and interesting new agronomy trials to our testing program, and we are excited to release our findings in this report.

During the summer of 2023, the PTI Farm hosted thousands of growers from throughout the United States as well as international countries including Australia, Germany, Canada, Argentina, Brazil, Hungary and the Ukraine. Farmers visited the PTI research farm to dive into agronomy field trials, see and understand real world agronomic problems, and were even able to experience some of the latest and greatest state-of-the-art technology in our ride and drive “SandBox” area. Field days started in July and lasted until the 3rd week of September.

For the 2023 PTI Yield Summary Data, net returns are calculated with corn prices of \$5.31/Bu. and soybeans at \$13.09/Bu. These prices represent average **cash** prices for new crop 2023 corn and soybeans from the period of October 1st 2022, through October 1st, 2023. This simulates how growers could sell new crops throughout the year.

At the bottom of each trial summary page, a brief explanation is listed to show Planting Date, Hybrid or Variety, Population, Row Width, Crop Rotation, and Commodity Price/Bu. and Pricing information that pertains to the products being evaluated. Most starter fertilizer trials at the PTI Farm have a \$30 to \$40 re-allocation credit applied to each product in testing. This approach allows us to use the total intended fertility needed for soil test build-up and yield maintenance but allows the planned use of both dry fertilizer in the fall and liquid product on the planter without over-spending or over-applying more nutrients than needed. To accomplish this, we have reduced our dry fertilizer rates by \$30 to \$40/A. to account for the reallocation. All control tests in each study get the additional fertilizer to achieve a typical 100% program without starter fertilizer on the planter.

Fall Dry Fertilizer: \$30-40 Reduction + At-Plant Liquid Starter

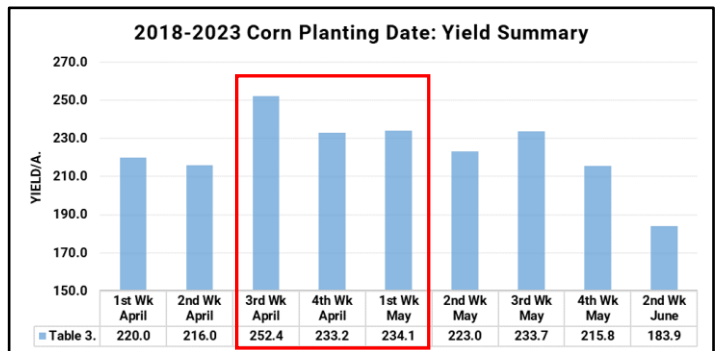
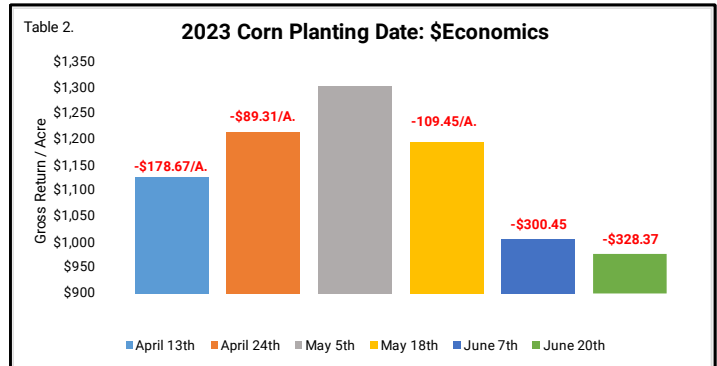
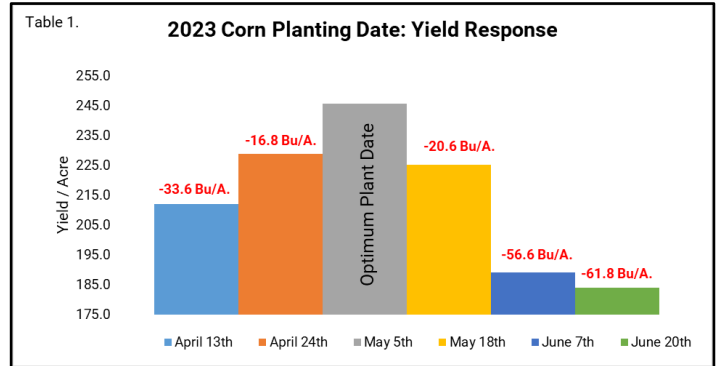


Corn Planting Date Study

Objective: To evaluate various corn planting dates throughout the spring to determine the optimum planting date. Once optimum planting date is discovered, economics can then be analyzed to determine yield loss and cost per acre when planting dates were not implemented within the optimum planting window.

Results: Later corn planted on May 5th achieved this year's optimum plant date at 245.7 Bu/A. (Table 1). Early planting dates of April 13th and April 24th suffered yield losses of **-33.6** to **-16.8 Bu/A.** Pushing planting date later to May 18th offered losses of **-20.6 Bu/A.**, June 7th losses of **-56.6 Bu/A.** while the latest plant date of June 20th was **-61.8 Bu/A.** off the pace from optimum plant date. Table 2. illustrates losses of **-\$89.31** to **-\$178.67** when pushing planting dates too early. Late planting dates suffered net losses of **-\$109.45** in the late may planting however June plantings suffered the largest losses in the study of **-\$300.45** to **-\$328.37.**

Table 3. summarizes the average yield from week-to-week plantings over a six-year time-period from 2018-2023. Over this timeframe, the ideal planting date for corn has been the 3rd week of April through 1st week of May. Highest yield losses have been ultra-early planting dates (1st and 2nd week April) with losses of **-9.5 Bu/A.** to **-13.5 Bu/A.**, as well as the 2nd week of June with losses of nearly **-45.6 Bu/A.**



Corn Starter Fertilizer Response by Planting Date Study

Objective: To monitor the performance of starter fertilizer at various planting dates. When does starter fertilizer give the highest returns? Does starter fertilizer respond differently at earlier planted dates versus later? In this study we evaluate five planting dates consisting of April 13th, April 24th, May 5th, May 18th and June 7th with and without a starter fertilizer, monitoring its performance throughout the planting season.

The starter fertilizer program used for this study consists of the following:



<u>Product</u>	<u>Fertilizer Analysis</u>	<u>Placement of Fertilizer</u>
6 Gal/A. Nachurs® Triple Option®	4-13-17-1S	FurrowJet® 3-Way
1Qt/A. Nachurs® Face Off®	1-0-1-.3Cu-.6Mn-.005Mo-3Zn	FurrowJet® 3-Way
2 Qt/A. Nachurs® K-fuel®	0-0-24	FurrowJet® 3-Way
5 Gal/A. Nachurs® Throwback®	9-27-4-4S	Conceal® Single Band
20 Gal/A.UAN	32-0-0	Conceal® Single Band
3 Gal/A. Nachurs® K-Fuse®	6-0-12-12S	Conceal® Single Band

Figure 1. FurrowJet® Placement

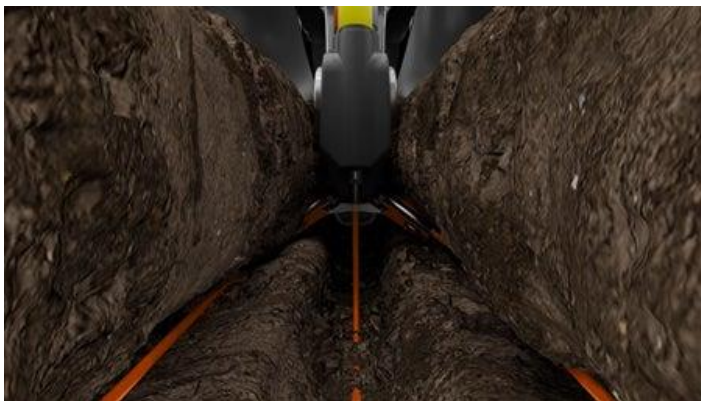


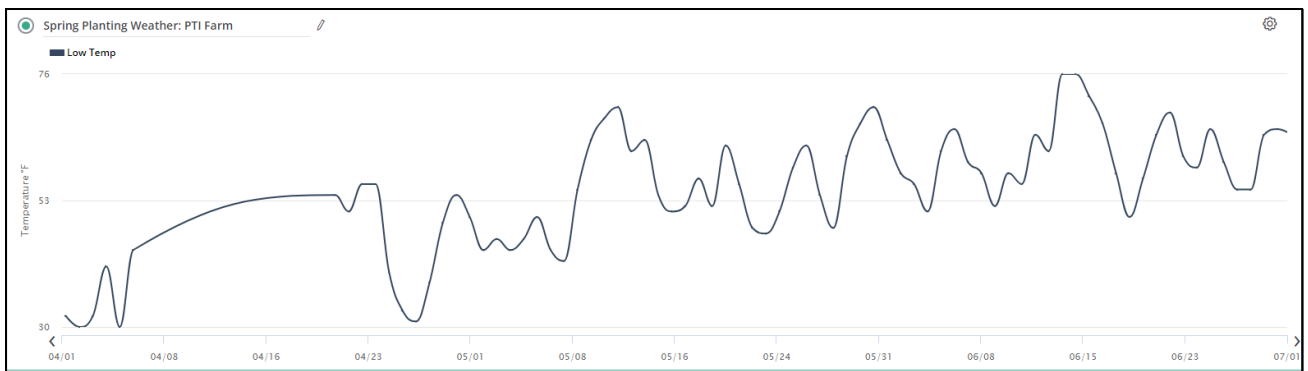
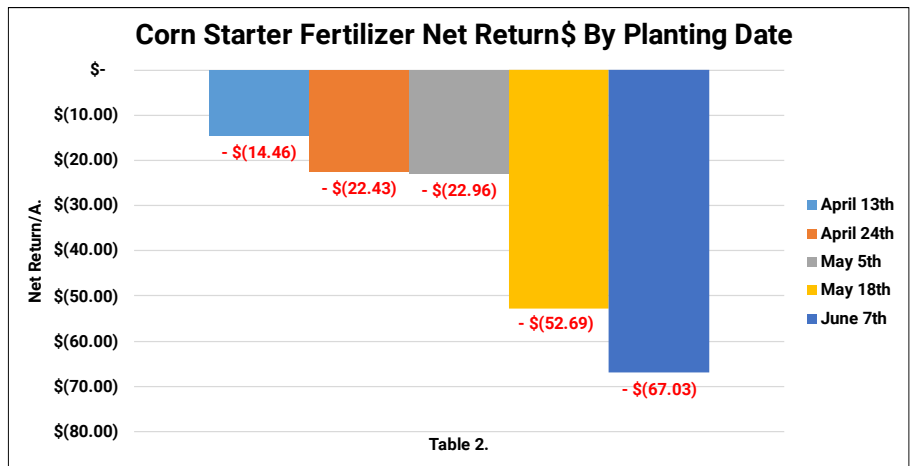
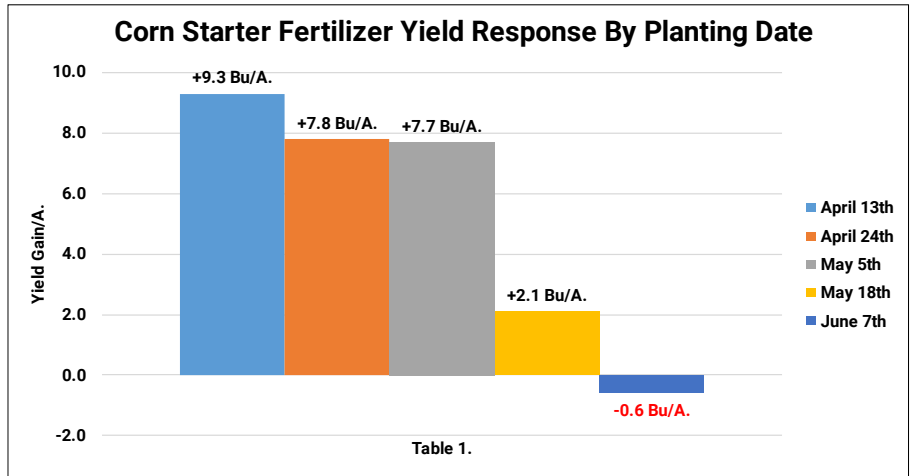
Figure 2. Conceal® Placement



Corn Starter Fertilizer Response by Planting Date Study Continued

Results: Table 1. illustrates that every planting date achieved yield gains from starter fertilizer, except the late June planting date. All other April and May planting dates resulted in yield gains of +2.1 to +9.3 Bu/A.

Weather data (listed below) proved cold soil temperatures that did allow for a perfect environment for excellent starter fertilizer response, however, economics indicate negative return on investment for all planting dates. Losses ranged from **-\$14.46/A.** on the earliest planting date, to increased losses of **-\$22.43** to **-\$67.03/A.** These disappointing revenue losses are all the result of the on-going high cost of fertilizer.

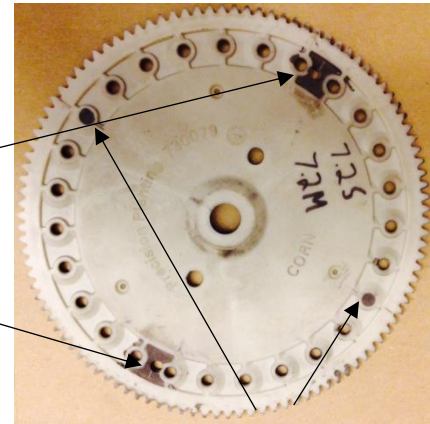


Planting Date: Varied Hybrid: GH10L16 Population: 36K Row Width: 30" Rotation: CAB Corn Price: \$5.31
 Starter Program Cost: \$103.85 \$40 Fertilizer Reallocation

vSet® Planter Singulation Study

Objective: To evaluate how improper seed singulation affects corn yield. Modified vSet® seed plates with plugged and extra holes were used to create skips and doubles. These “goof” plates created an average of 95% spacing accuracy vs. the control at 99.5%.

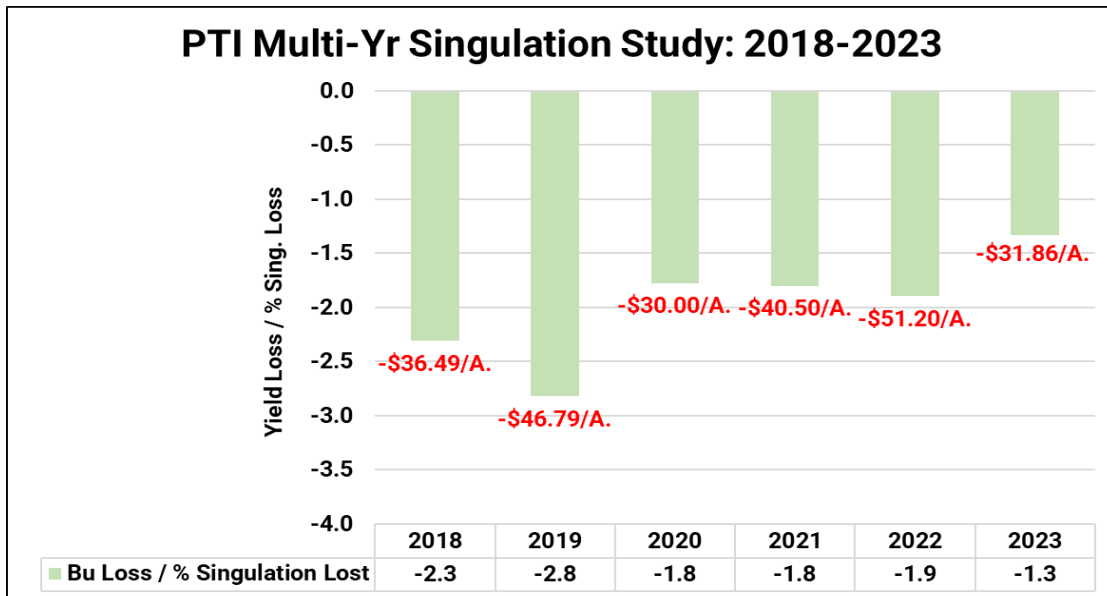
Extra Holes = Doubles



Plugged Holes = Skips

Results: The table below illustrates 95% seed singulation resulted in economic losses of **-\$39.47/A.** over a 6-yr period of 2018-2023.

Over this same time period, for each percentage of singulation lost, yield was decreased by an average of **-1.98 Bu/A.**



SmartDepth® Corn Planting Depth Study

Objective: To evaluate yield and economic performance of various manual corn planting depths consisting of 1" to 3" in ¼" increments, compared to automated variable depth planting using SmartDepth® control.

Digging seeds is a time consuming yet important task at planting time (Figure 1). Getting your eyes on the furrow where the seeds are placed will allow you to understand if those seeds are in an environment to thrive. Is the seed being planted in adequate moisture? Until now, we didn't know this for every seed, and we were unfortunately simply guessing.

With a SmartFirmer® sensor (Figure 2.) you can now have virtual eyes in the furrow. Soil moisture is a critical component for seed germination, uniform plant emergence, and ultimately crop yield. SmartFirmer® sensors give row-by-row visibility to soil moisture in the seed furrow, allowing farmers to choose the right planting depth as soil conditions change. Currently, the recommendation for ideal furrow moisture levels to achieve adequate corn emergence, is near 32%. Using the 20|20® monitor (Figure 3.) in tandem with SmartFirmer® sensors, we now have the ability to evaluate furrow moisture in real-time. Based on this real-time information, growers can make decisions based on live sensing data.

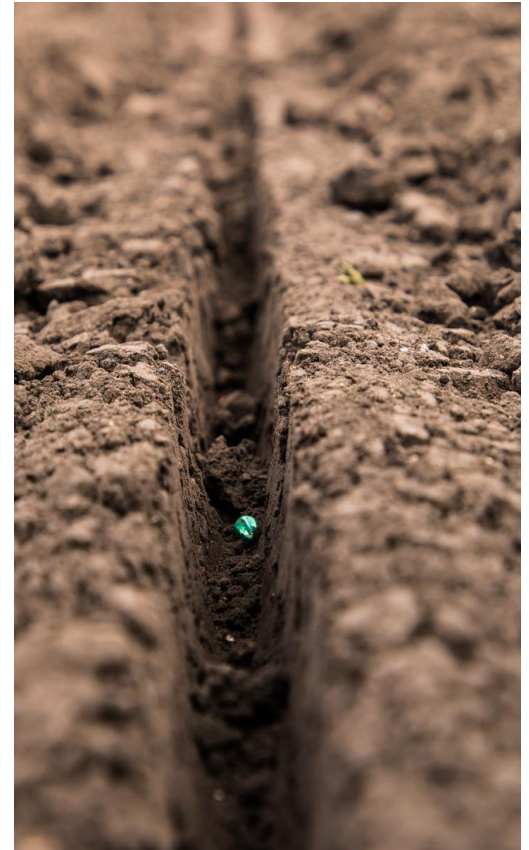


Figure 1. Seed Furrow



Figure 3. 20|20® Monitor System



Figure 2. SmartFirmer® Sensor

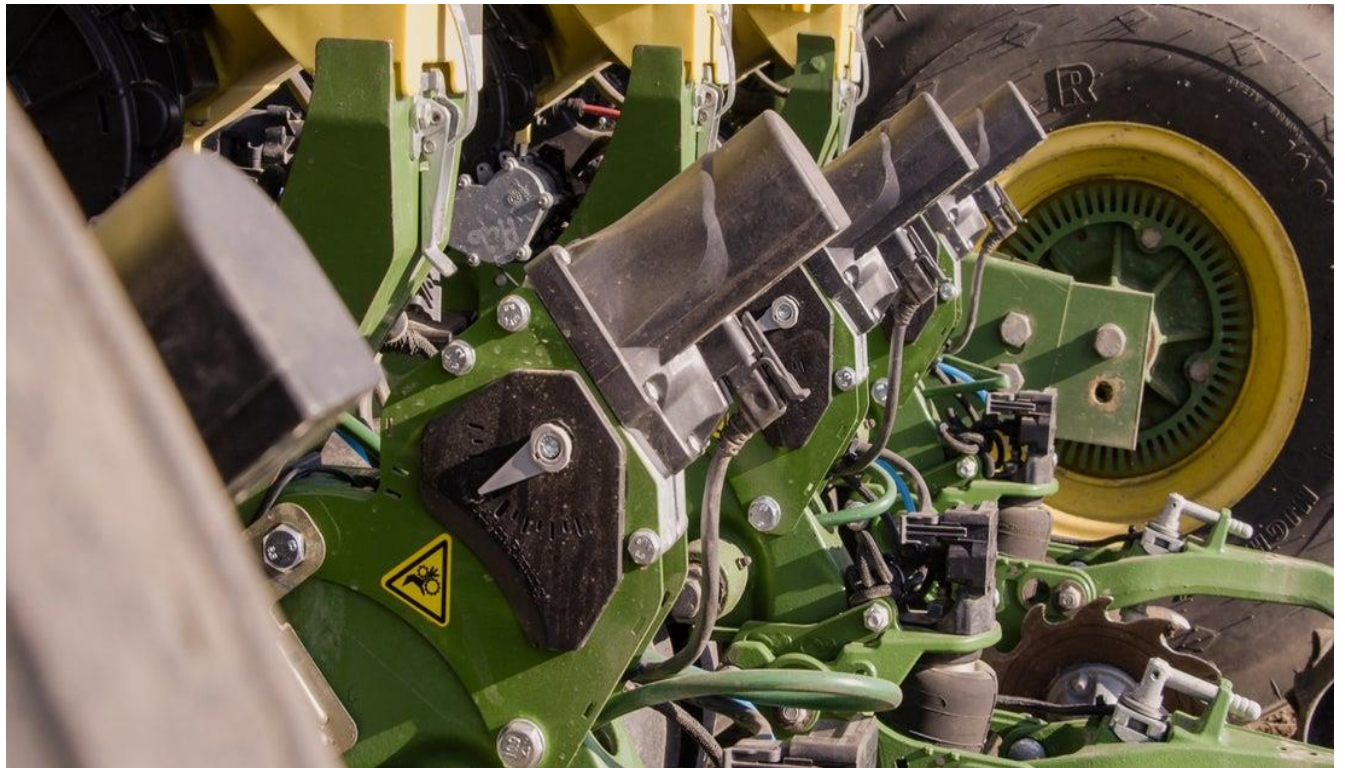
SmartDepth® Corn Planting Depth Study Continued

Figure 4. illustrates SmartDepth®, a unique product that takes the technology one additional step further, allowing planting depth to be changed on a planter, by section or individual row basis. This can be done manually from the tractor cab and 20|20® console, or automatically using furrow moisture values from SmartFirmer® sensors. Growers can customize their own settings to optimize both furrow moisture and planting depth values (Figure 5). This control allows growers to measure, react, and take control of planting depth to optimize emergence timing.



Figure 5. SmartDepth® Customization Screen

Figure 4. SmartDepth® Control System

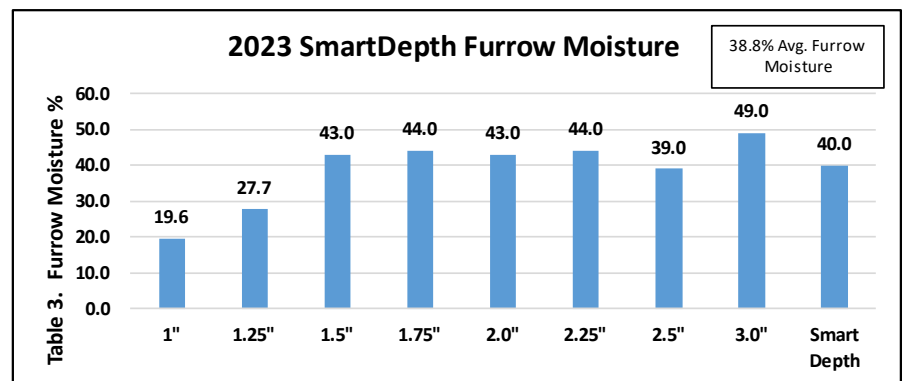
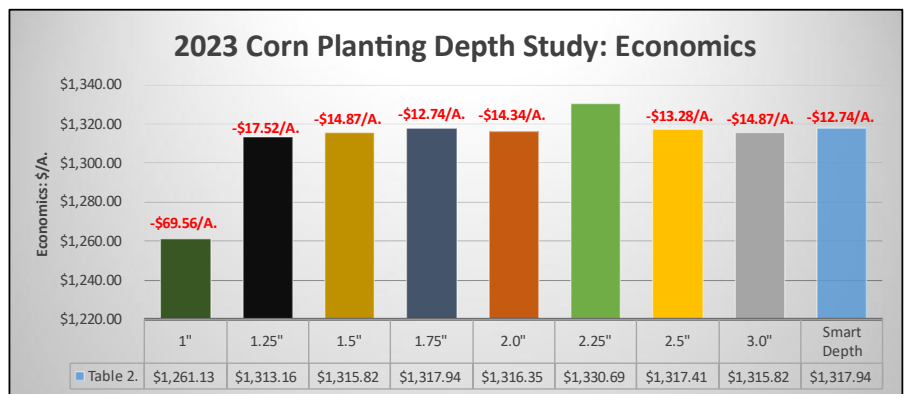
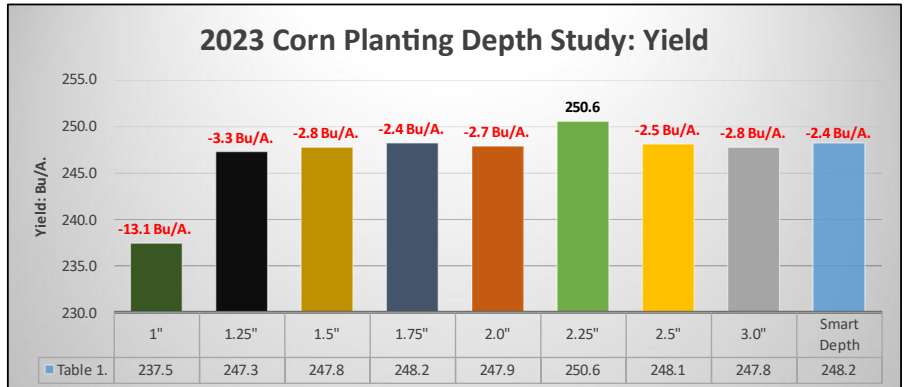


SmartDepth® Corn Planting Depth Study Continued

Results: Tables 1-2. reveal that SmartDepth® achieved corn yield within 2.4 Bu/A. of the optimum planting depth of 2.25" and economic variance of only \$12.74/A.

The telling story in this study is furrow moisture levels. Table 3. illustrates average furrow moisture of 38.8% Currently, the recommendation for ideal furrow moisture levels to achieve adequate corn emergence is near 32%. Table 3. indicates all planting depths deeper than 1.25" had furrow moisture over 32%. This indicated good field moisture and deep planting depths were not needed. At 1", and 1.25" planting depths we lacked moisture, and that's why we saw big yield losses at those depths.

By using SmartDepth®, SmartFirmer® and a 20|20® monitor system, growers can obtain perfect planting depths just below the furrow moisture line.



Keeton® Seed Firmer Study

Objective: This study evaluates the benefits of Keeton® Seed Firmers (Figure 1). Seeds don't always land right in the bottom of the trench where they belong. With its unique, in-the-trench design, the Keeton® Seed Firmer gently firms those seeds to the bottom of the V-trench (Figure 2). The result is even depth, correct seed-to-soil contact, and most importantly, uniform germination.

Results: Table 1. illustrates multi-year yield data over the time period of 2018 – 2023 at the PTI Farm. The presence of Keeton® Seed Firmers resulted in average yield gains of +2.8 Bu/A. As for economics, this yield gain equates to additional economic gains of +\$12.61/A. compared to not using a seed firmer.

At a cost of \$40/row for Keeton® Seed Firmers and quick attach brackets for a 16-row planter, using the +\$12.61/A. increase in revenue, break-even occurs at only 51 acres.

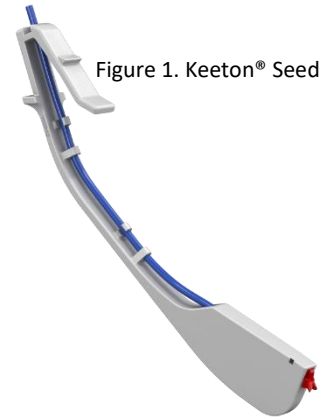
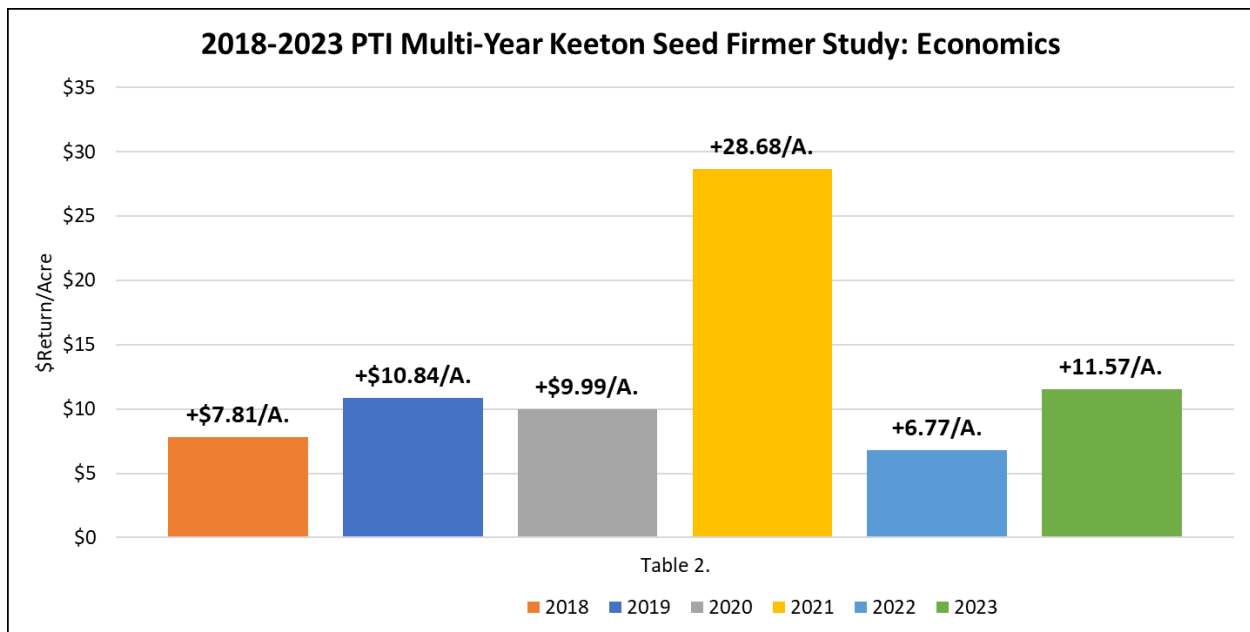


Figure 1. Keeton® Seed Firmer

Figure 2. Good Seed-to-Soil Contact from Keeton® Firmer



Planting Date: 5/15 Hybrid: DKC 66-17RIB Population: 36K Row Width: 30 Rotation: CAB Corn Price: \$5.31

Reveal® Residue Management Study

Objective: This study evaluates the yield and economic benefit of Reveal®, a frame mounted row cleaner system in a corn after corn strip-till environment.

Residue management is a necessary part of today’s operation to maximize profitability. Tougher stalks and more corn-on-corn acres mean a heavier load of residue that needs to be controlled. Residue in the seed trench competes with seedlings for moisture and can harbor diseases.

Reveal® (Figure 1-2.) is frame mounted, so unlike other row cleaners, it gets rid of that row unit chatter. It has an internal gauge wheel that precisely controls the depth of the cleaning tines. It also has an airbag that makes sure the depth that it’s set at, stays consistent. The pressure of the airbag can be controlled on the 20|20® monitor or utilizing a manual controller in the cab.

Figure 1. Reveal® System



In this agronomic study, we compared the absence of row cleaners, and floating row cleaners to that of Reveal® at the following notch and PSI settings:

1. Reveal® Notch 1 10# Down
2. Reveal® Notch 1 20# Down
3. Reveal® Notch 1 30# Down
4. Reveal® Notch 1 40# Down

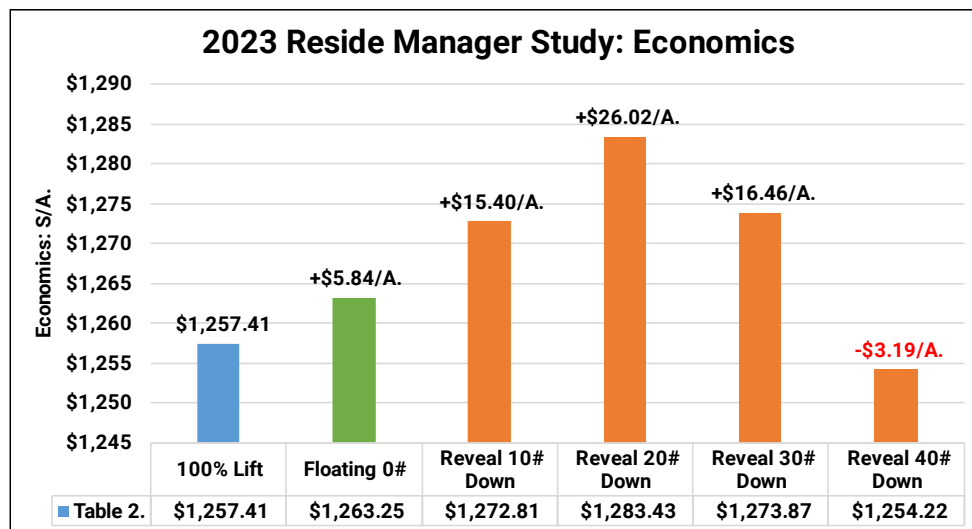
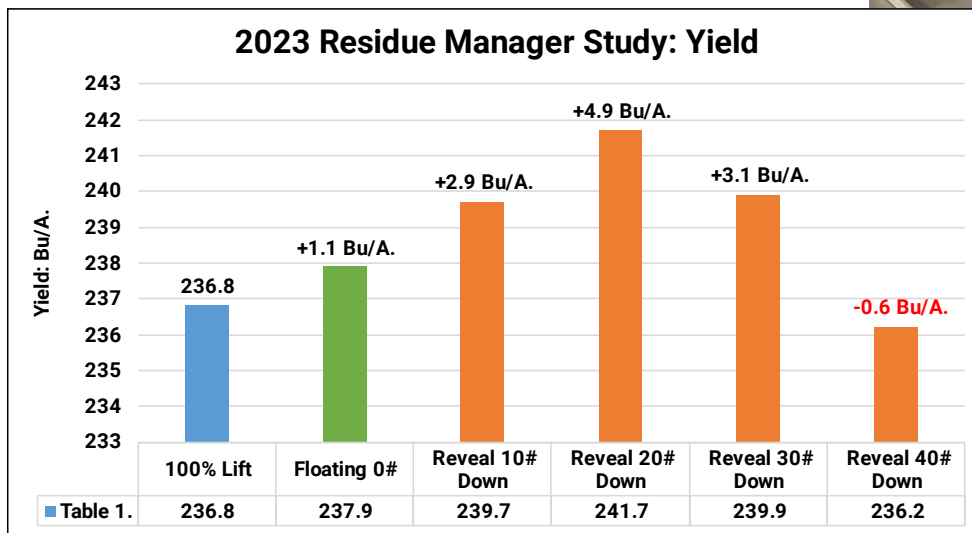


Figure 2. 20|20® System



Reveal® Residue Management Study Continued

Results: Table 1. illustrates the summary of all residue manager systems. Compared to the control of 100% lift, the Reveal® residue management system at 20# PSI down in notch 1, wheel settings, provided the highest yield gains in the study, with gains of +4.9 Bu/A, and corresponding return on investment of +\$26.02/A. Reveal® in general provided +2.9 to +3.1 yield gains at the 10# and 30# PSI down setting. However, as PSI increased to 40#, yield response fell to losses of only **-0.6 Bu/A.** compared to 100% lift. Floating row cleaners realized +1.1 Bu/A. gain to that of the control.



Multi-Year Day of Emergence Study

Objective: This multi-year study illustrates the impact of yield loss when corn plants emerge from the soil surface on an inconsistent basis. Flag testing implementation (Figure 1.) was used to monitor the emergence timing of young plants each year. As corn first started to emerge from the soil surface, flags were placed at five different timings to identify the emergence of all plants within the study.

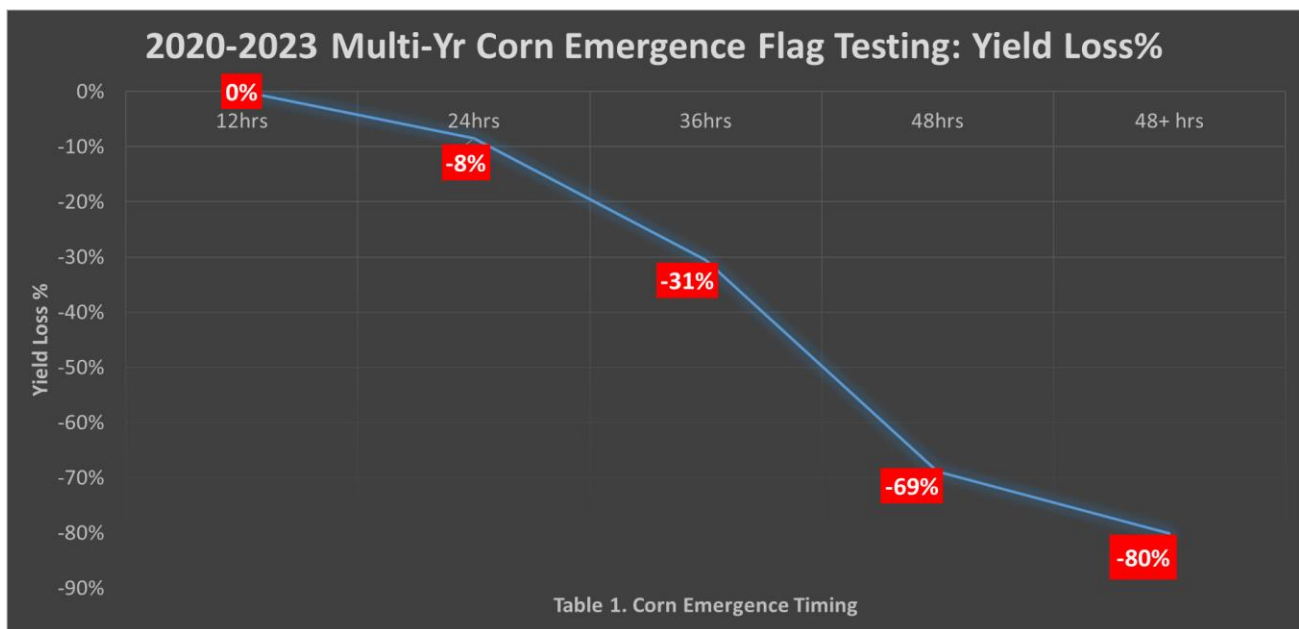
Figure 1.



Protocol:

- 12 hours =** 1st initial plants to emerge
- 24 hours =** Plants that emerged 24 hours later
- 36 hours =** Plants that emerged 36 hours later
- 48 hours =** Plants that emerged 48 hours later
- 48+hours=** Plants that emerged >48 hours later

Results: Manual ear checks were completed to calculate potential yield loss from late emerging plants. Table 1. below summarizes yield loss as emergence varied over the 4-year study. Plants that emerge in the first 12 hours are considered the best achievable performance and therefore used as the baseline control with 100% yield potential. As plants emerged 24 hours later, **-8%** yield losses were realized compared to the first emergers. As emergence continued to 36-hour delay, yield fell to **-31%** losses. The 48-hour delay in emergence resulted in yield deficits of **-69%** and finally, the latest emergers that came up >48-hours proved devastating losses of **-80%**.



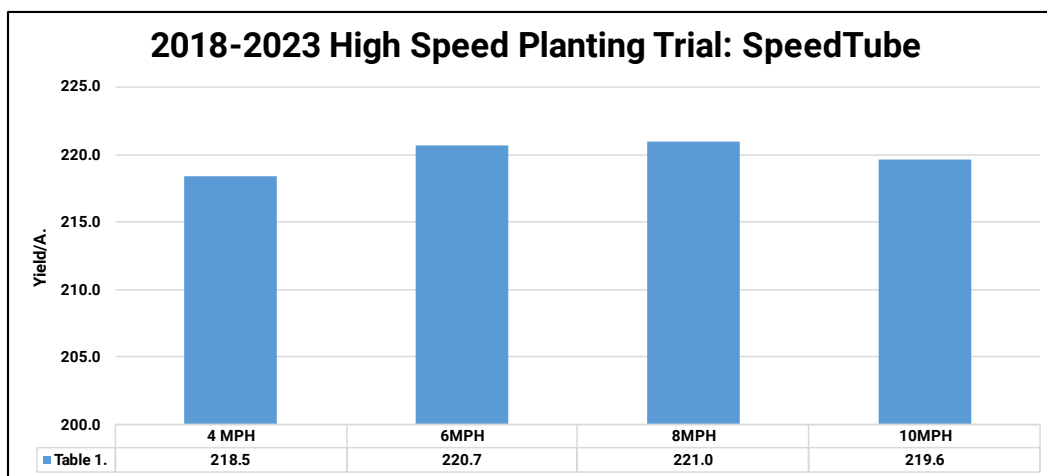
SpeedTube® Corn High Speed Planting Study

Objective: To evaluate yield response of planting speeds of 4, 6, 8, and 10 MPH with a SpeedTube® system. This high-speed planting technology takes the place of conventional seed tubes and consists of a flighted belt. By transporting each seed to the furrow, there is no opportunity for seeds to ricochet into the trench. Even at twice normal planting speeds, seed arrives safely at the bottom of the trench, spaced evenly, every time.



Results: Table 1. summarizes multi-year data from 2018-2023, with SpeedTube® planting at speeds of 4, 6, 8, and 10 MPH only varying 2.5 Bu/A.

With traditional planting speeds typically near 5 mph, this data would suggest that growers could plant twice as fast without sacrificing planter performance. Being able to plant almost twice as fast this would allow farmers to wait until planting conditions are perfect to plant, resulting in the best yields.



Planting Date: May 15th Hybrid: DKC 65-95RIB Population: 36K Row Width: 30" Rotation: CAB Corn Price: \$5.31

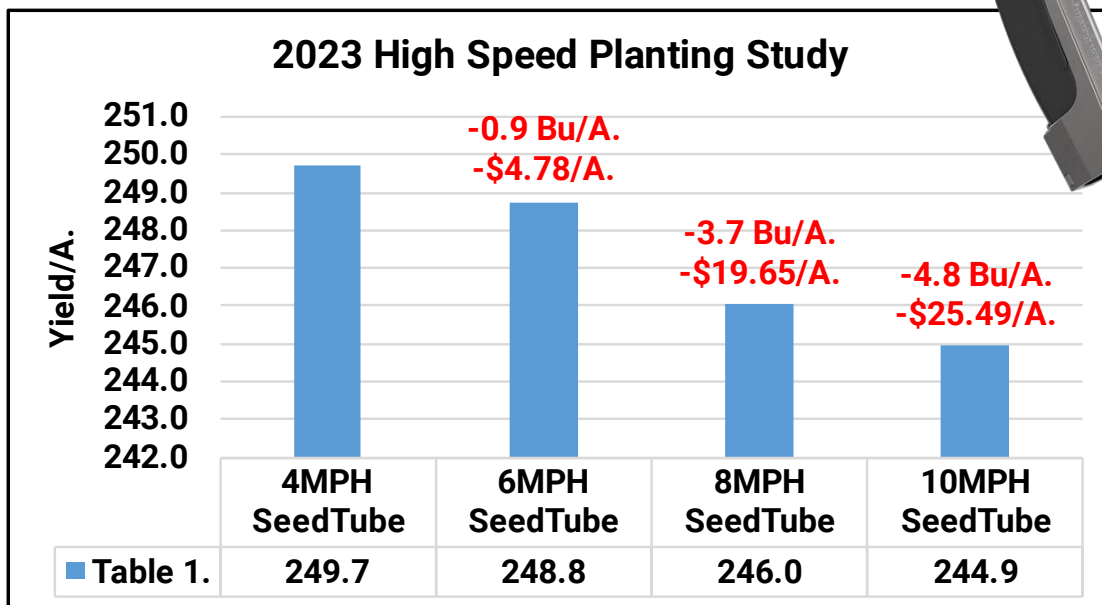
WaveVision® SeedTube Corn High Speed Planting Study

Objective: To evaluate yield response of planting speeds of 4, 6, 8, and 10 MPH with a WaveVision® Seed tube system. Seed tubes are designed for typical planting speeds of 4 to 6 MPH.

Figure 1. WaveVision® SeedTube

WaveVision® is a seed sensor within the seed tube that counts only seeds and not dust, giving you confidence that the population you see on your monitor is the population that you're planting. WaveVision® does not incorporate an optical sensor in the housing, meaning there is no opportunity for seeds to ricochet into the trench. Instead, high-frequency radio waves measure mass instead of shape.

Results: Table 1. illustrates seed tube performance fell by **-4.8 Bu/A.** when increasing planting speed from 4MPH to 10MPH, resulting in losses of **-\$25.49/A.**



Corn Tillage/Closing Wheel Study

Objective: To evaluate the performance of non-sensing single-stage and two-stage automatic sensing closing systems in four different tillage practices including conventional, strip, vertical, and no-till.

Closing systems are designed to close the seed trench, eliminate sidewall smear, compaction and to remove air pockets, all while achieving good seed-to-soil contact.

Two Goals of Proper Closing

1. Remove Air Pockets
2. Lift and Fracture Side-Walls

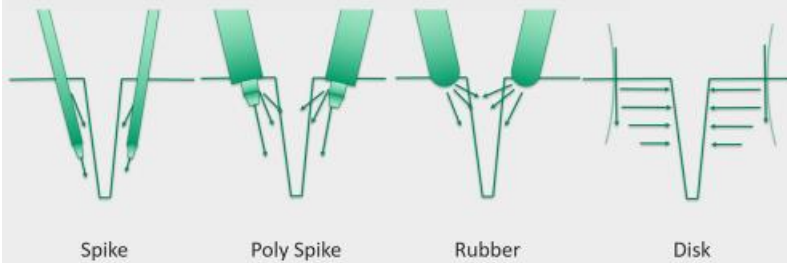


Figure 1. Air Pocket Causing Poor Seed to Soil Contact



Figure 2. Good Seed to Soil Contact

Corn Tillage/Closing Wheel Study Continued

This tillage/closing study evaluates yield and economics of six distinctly different types of closing wheel systems, in four different tillage systems including the following:



FurrowForce® Closing and Manual Control System:

- Advantages:
- Lifts and fractures sidewall compaction/smear
 - 2nd stage stitching and removal of air pocket
 - Ability for automatic sensing/control of soil variability
- Disadvantages:
- Rocks can be problematic, increased cost



Non-Sensing Traditional Dual Rubber Closing System:

- Advantages:
- Sealing or "Pinching" in dry conditions
- Disadvantages:
- Difficult to lift/fracture sidewalls, struggles to close furrow



Non-Sensing Dual Yetter Poly Twister® Closing System:

- Advantages:
- Lifts and fractures sidewall compaction/smear
 - Center ring acts as depth maintainer
- Disadvantages:
- Lightweight wheels require increased tension



Non-Sensing Martin-Till® fCrusher Closing System:

- Advantages:
- Tapered tooth design – Lightweight Cast
 - Allows firming and crumbling.
- Disadvantages:
- Single Stage, Potential to Overpack



Non-Sensing Dual Germinator® System:

- Advantages:
- Ring-only option for easy installation
 - Center ring acts as depth maintainer
- Disadvantages:
- Single Stage, Potential to Overpack

Corn Tillage/Closing Wheel Study Continued



Non-Sensing Martin-Till® Two Stage System:

- Advantages:
- Lifts and fractures sidewall compaction/smear
 - 2nd stage removal of air pocket
 - Multiple Manual Settings for easy adjustment
- Disadvantages:
- Manual control – no sensing

Four tillage systems were evaluated in the study to evaluate the difference in closing performance.

Vertical-Till (Figure 1.) In the fall after harvest, vertical tillage was used to mix, cut, and level residue in a 3” depth tillage pass. Herbicide was used as a burndown to control early season weeds in the absence of spring tillage.

No-Till: (Figure 2.) Planting directly into last year’s corn stalks with no tillage activity performed. Herbicide was used as a burndown to control early season weeds in the absence of tillage.

Conventional-Till (Figure 3.) In the fall after harvest, deep 13” ripping with aggressive cutting and mixing of residue. A spring soil finisher leveled before planting.

Strip-Till (Figure 4.) In the fall after harvest, 10” deep strips were created with a strip-till unit. Herbicide was used as a burndown to control early season weeds in the absence of spring tillage.

Figure 1. Kuhn® EXCELERATOR® XT 8010 Vertical Tillage



Figure 2. No-Till Planter



Figure 4. Kuhn® Krause® 1200 Gladiator® w/ Montag® Fertilizer Cart



Corn Tillage/Closing Wheel Study Continued

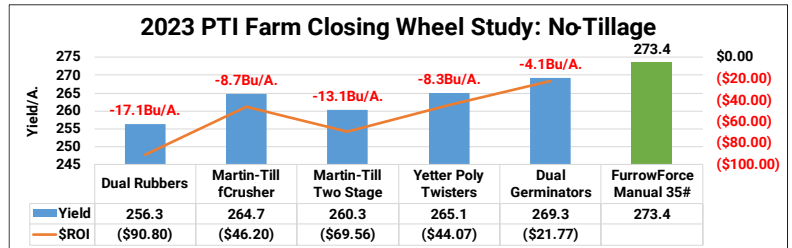
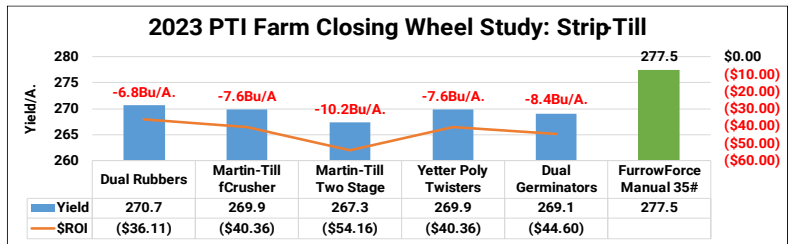
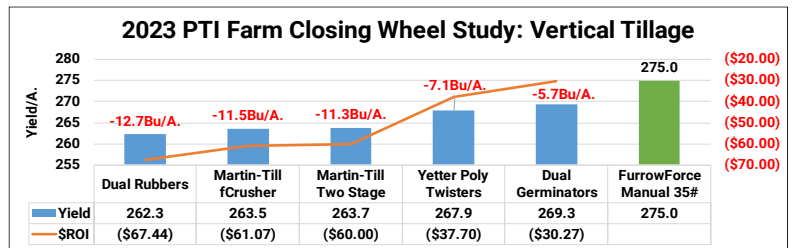
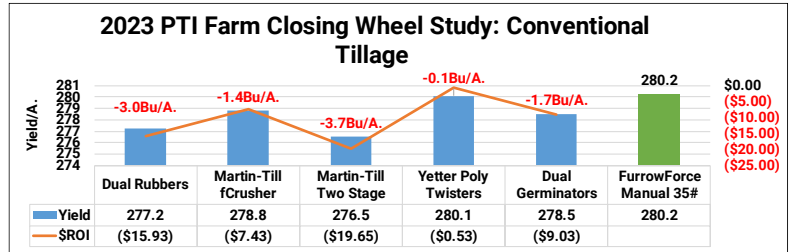
Results:

Conventional Till: Minimal yield variance occurred within all closing systems with a spread of only 3.7 Bu/A. Manual FurrowForce® outperformed all other closing systems in conventional tillage. Martin Manual 2-Stage system had the highest loss in this tillage losing **-3.7 Bu/A.** compared to Manual FurrowForce®

Vertical-Till: Manual FurrowForce® outperformed all other closing systems in vertical tillage. FurrowForce® proved positive yield gains compared to all other closing systems by +5.7 to +12.7 Bu/A. In this difficult to close planting environment, dual traditional rubbers proved highest yield losses of **-12.7 Bu/A.** with revenue losses of **-\$67.44/A.** All other closing systems resulted in revenue losses of **-\$30.27** to **-\$61.07/A.**

Strip-Till: FurrowForce® proved positive yield gains compared to all other closing systems by +6.8 to +10.2 Bu/A. All other closing systems performed similarly in this tillage system with revenue variance of **-\$36.11** to **-\$54.16/A.**

No-Till: FurrowForce® outperformed all closing systems with yield gains of +4.1 to +17.1 Bu/A. In this tougher to close type environment, all closing systems suffered, however dual traditional rubbers and the Martin Two Stage provided the largest discrepancy with yield losses of **-17.1** and **-13.1 Bu/A.** with economic losses of **-\$90.80** to **-\$46.20/A.**

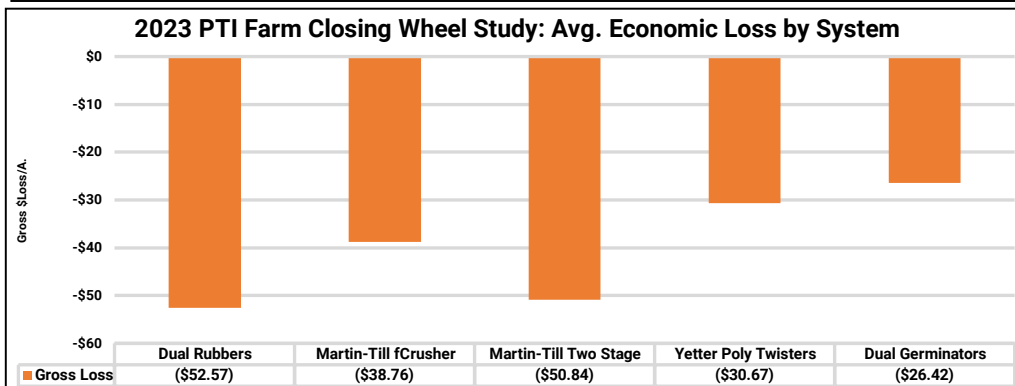
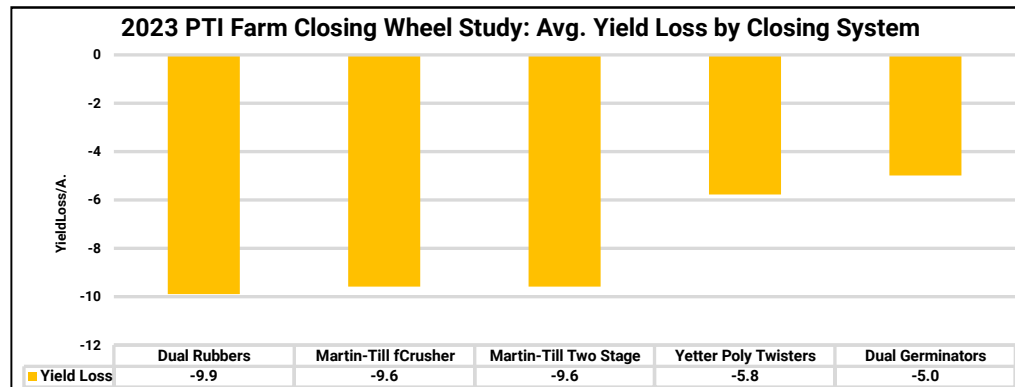


Corn Tillage/Closing Wheel Study Continued

Overall, FurrowForce® two-stage manual closing system resulted in average yield gains of +6.66 Bu/A. and additional revenue of +\$32.94/A. across all tillage environments.

However, the clear advantage for FurrowForce® occurred in reduced tillage environments such as no-till and vertical tillage. In these programs, average yield gains of up to +10.3 to +9.66 Bu/A. with increased revenue of +\$54.48 to +\$51.30/A. clearly indicate that in tougher closing situations, a more robust system is needed to effectively close the furrow.

In summary, for years planters have struggled with closing systems with manual settings that offered the inability to account for and change for varying soil conditions. Today, we are excited that technology finally exists



where farmers can use sensing technology on the planter row unit to determine how much force is needed on closing systems to address soil variability. By using a robust 2-stage closing system, load pin and sensing architecture, partnered with a 20|20® monitor, farmers can be confident of closing the seed trench, eliminating sidewall compaction/smearing, and removing air pockets all while planting through various seedbed conditions on a pass-pass basis.

Case IH 2150 FurrowForce® Retrofit

Objective: To evaluate the performance of a Case planter with a traditional Case 2-Stage Manual closing system (Figure 1.) compared to retrofitting the planter with Automated FurrowForce. (Figure 2.)

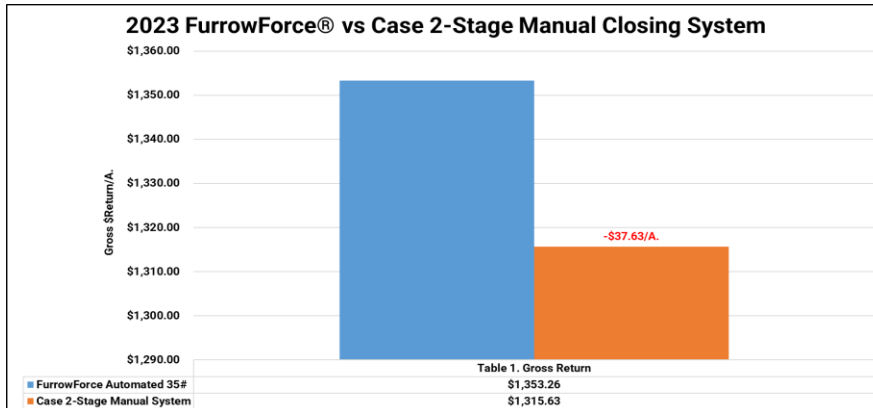
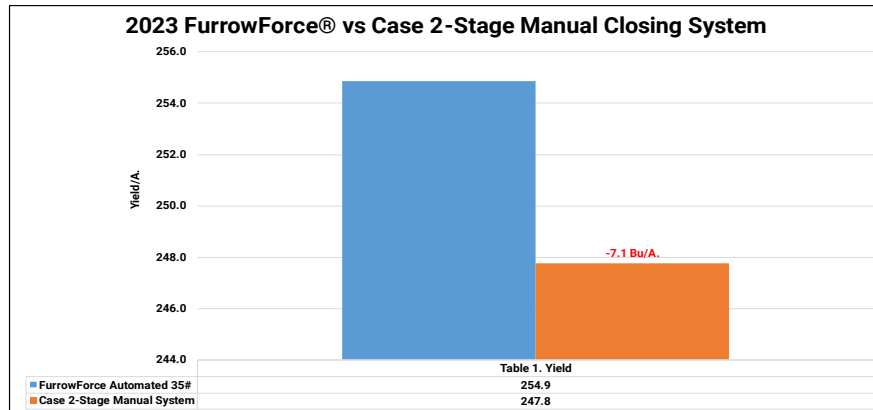
Results: Table 1. illustrates the yield response of retrofitting your Case planter with Automated FurrowForce. Automated FurrowForce resulted in a yield advantage of +7.1 Bu/A. resulting in an economic gain of +\$37.63/A.

At a cost of \$1650/Row for automated FurrowForce for a 16-row planter, using the saved cost of ordering planter with no closing systems and the increased revenue of +\$37.63/A., break even occurs at 234 acres.

Figure 1. Case Manual 2-Stage Closing System



Figure 2. FurrowForce Automated Closing System



DownForce Management Study

Objective: Planter row unit downforce is a common agronomic issue that often goes unaddressed. This study evaluates yield impact of implementing proper downforce, compared to too light or too heavy row unit settings. When downforce matches field conditions, the depth of planting is consistent and correct. Too light of row unit downforce causes planting depth to shallow up, potentially placing seed in dry soil, thus creating poorly rooted plants that struggle for water and nutrients. Conversely, too much downforce can lead to furrow side-wall compaction, also creating an environment that can cause limited plant access to water and nutrients.

DeltaForce® system replaces the springs or air bags on your planter with hydraulic cylinders (Figure 1.) It automatically increases or decreases weight with military precision, on each row individually. When one row encounters conditions different than another (wheel tracks, old roadbeds, clay knobs, headlands, etc.), each will adjust independently (Figure 2). Row by row, foot by foot, and seed by seed, you produce an environment that fosters uniform germination, optimum growth, and maximum yield.

Figure 1. DeltaForce® Cylinder



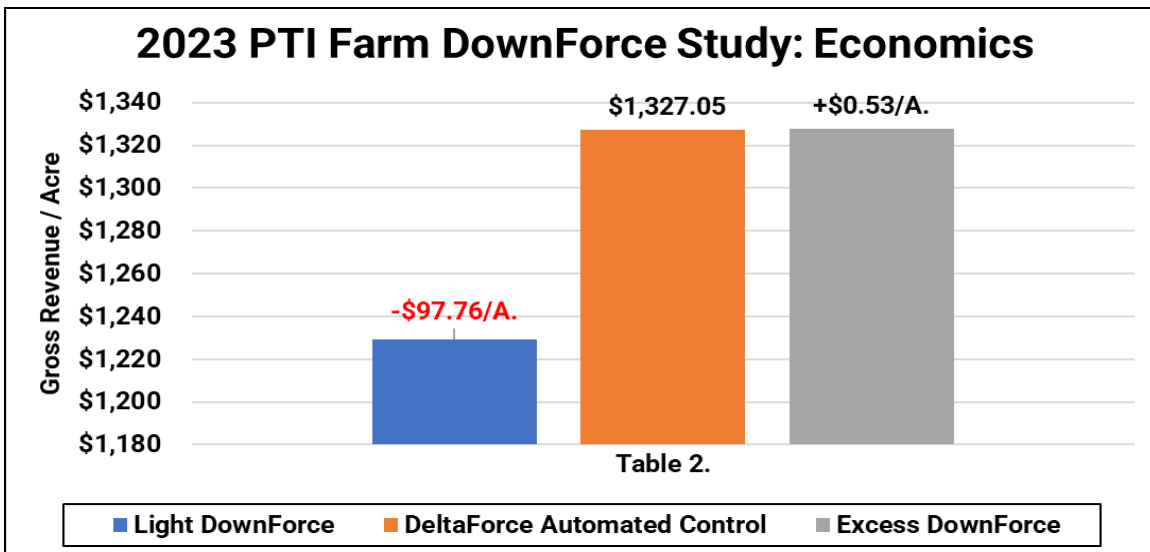
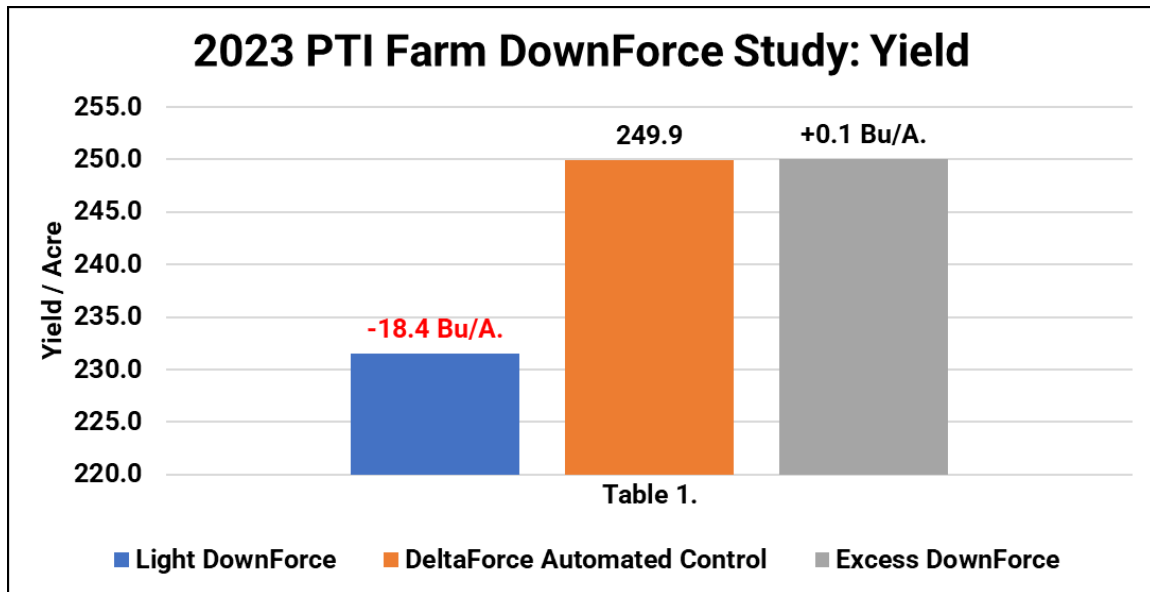
Figure 2.



DownForce Management Study Continued

Results: Table 1. illustrates the yield response of DeltaForce® automated control (Custom 120#) compared to excessive and light downforce settings. Too light of downforce (175# lift, 100# down) resulted in yield decreases of **-18.4 Bu/A.**, while excess downforce (550# down, 100# up) actually offered a small yield increase of +0.1 Bu/A.

Table 2. reveals the economics of the automated downforce system. Light downforce suffered the largest overall losses of **-\$97.76/A.**, while excess downforce resulted in a small gain of +\$0.53/A.

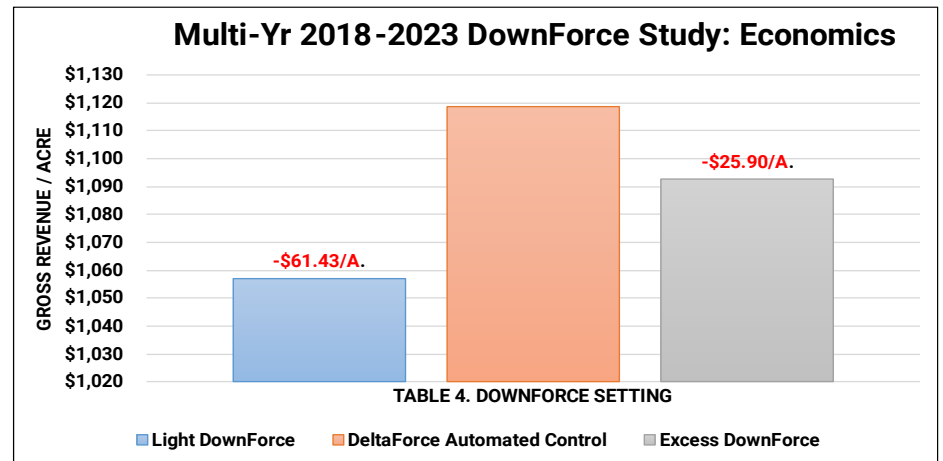
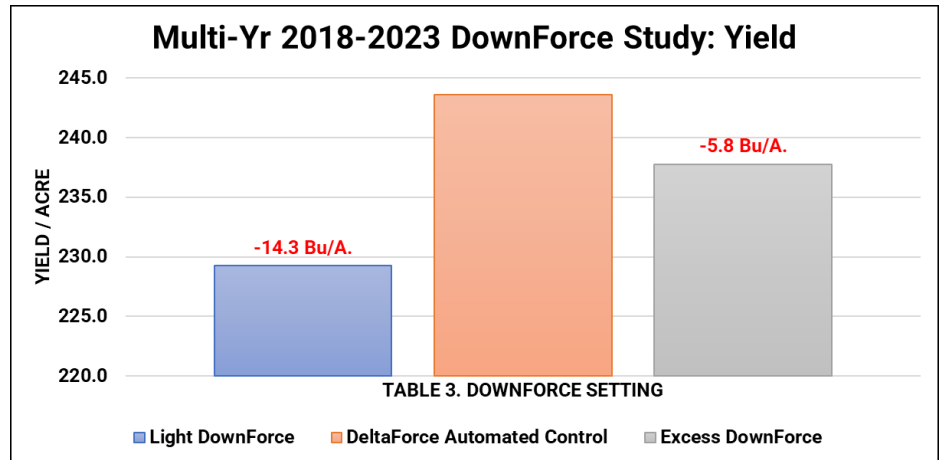


DownForce Management Study Continued

Table 3. illustrates multi-year downforce yield results over the time-period of 2018 to 2023 at the Precision Planting PTI Farm. During these growing seasons, light downforce resulted in yield losses of **-14.3 Bu/A.** compared to automated control with a DeltaForce® system. Excess downforce resulted in losses as well, however at only **-5.8 Bu/A.**

Table 4. depicts the same multi-year time-period, but economics rather than yield. Over 2018-2023, light downforce resulted in economic losses of **-\$61.43/A.** and excess downforce of **-\$25.90/A.**

In summary, when downforce matches field conditions, the depth of planting is consistent and correct. By measuring with the DeltaForce® system, farmers can react and take control to ensure proper downforce and eliminate yield and economic losses.

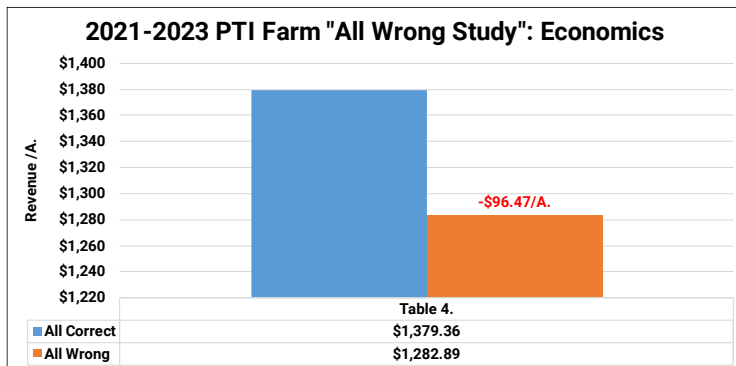
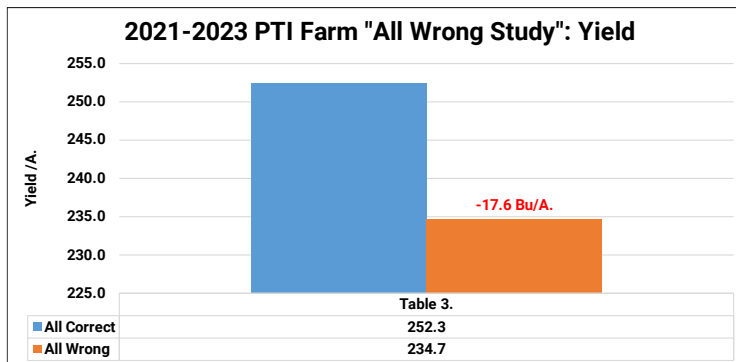


Planting Date: 5/15 Hybrid: DKC 66-17RIB Population: 36K Row Width: 30" Rotation: CAB Corn Price: \$5.31

Planter “All Wrong Study”

Objective: This planter trial is designed to simulate yield and economic effects when a grower gets downforce, residue manager settings, and singulation incorrect on the planter, all at the same time. For this study we implemented light downforce, “goof” plates to achieve 95% singulation, and removed the use of residue managers.

Results: Table 1. reveals “All Wrong” planter settings caused average yield losses of **-17.6 Bu/A**. Table 2. Calculates average economic losses of **-\$96.47/A**. when all three planter settings were incorrect. For more information on individual performance of these attributes, please see multiyear summary results for down force management, residue management trials, and singulation studies.



mSet® Multi-Genetic Planting Study

Objective: To analyze the yield and economic benefit of implementing mSet® single meter multi-genetic technology to place specific corn hybrids for individual spatial management zones.

mSet® is an upgradeable product to vSet® meters and vDrive® controller, which couples a seed selector added to the hopper to switch hybrids, and a seed pool level sensor in the meter (Figure 1.) The level sensor tells the seed selector when the meter needs more seed, and it drops a dose of seed into the meter. This continually happens until it is time to switch hybrids. At hybrid change, the level sensor will let the seed pool run low, then call for a dose of the other hybrid to enter the meter just in time for the change, leading to a short transition between hybrids. The seed pool is controlled by the mSet® selector (Figure 2.), providing the correct hybrid in the meter, and allowing the vSet® meter to accurately singulate those seeds. The ultimate result is the hybrid you select, planted in the area of the field you select, planted with highest accuracy of singulation. Additionally, for those who want to both plant fast, and place hybrids by spatial zone variability, SpeedTube® system can be used in tandem with multi-genetic technology (Figure 3).

Figure 1. mSet® Box

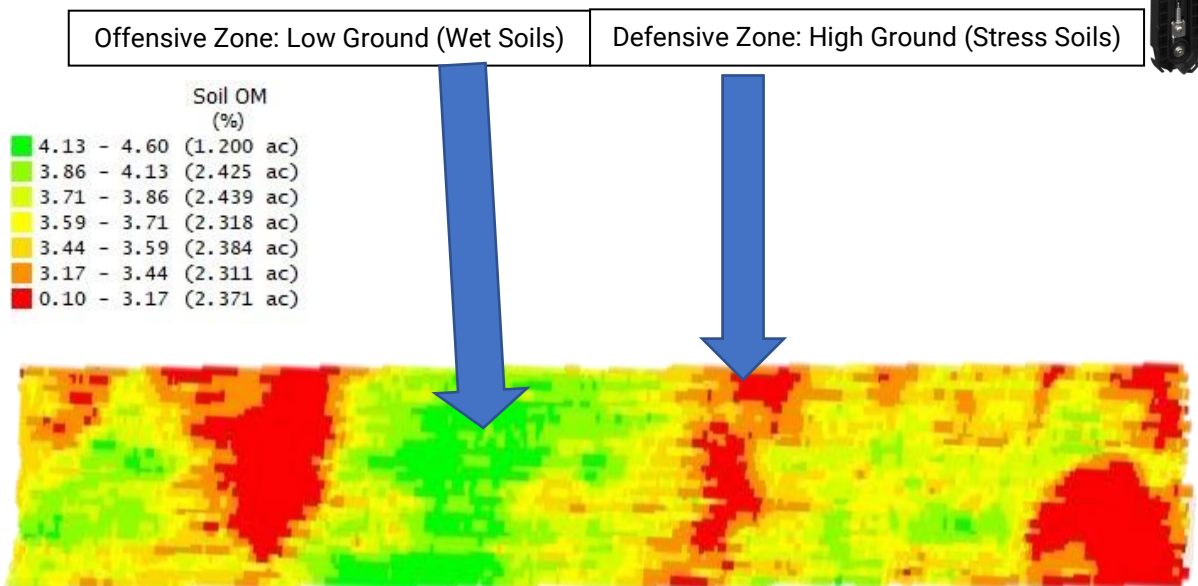


Figure 3.



Figure 2. mSet®

Figure 4. Offensive and Defensive Spatial Zones



Multi-Genetic Planting Study Continued

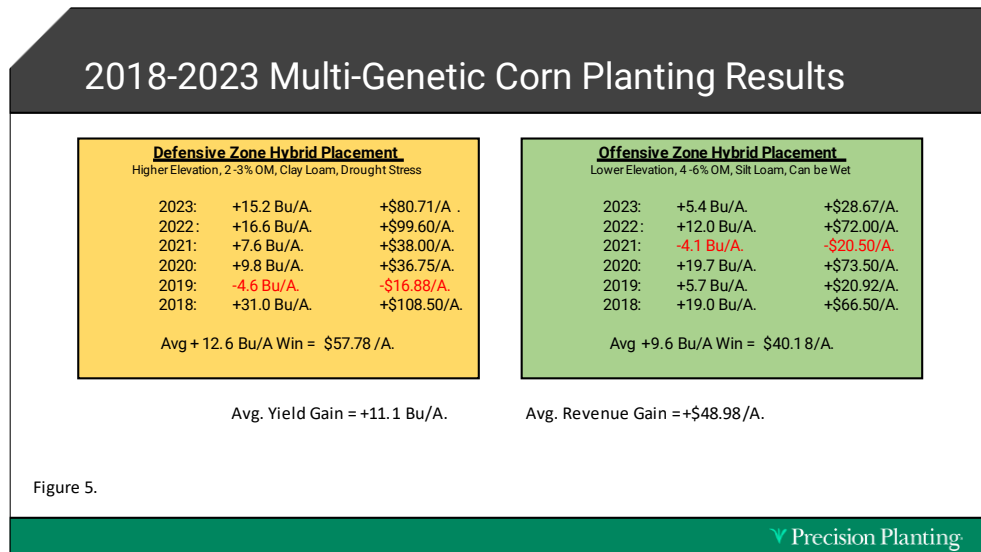
Results: For this spatial study, Bayer short corn platform was used to evaluate shorter hybrids in both offensive and defensive type soils. Bayer RT6203VX2 was used as our offensive corn hybrid in the lower elevation, higher OM, but potentially saturated soils. Conversely, Bayer RT6203VX2 was used as the defensive hybrid planted into the higher ground, lower OM, and potentially droughty soils. Each genetic package was placed into the appropriate matching spatial management zone (Figure 4). Test blocks were planted to evaluate the yield performance when hybrids were placed correctly, as well as incorrectly.

Figure 5. illustrates the results of multi-hybrid planting in 2023. Correct hybrid placement in the defensive zones resulted in yield gains of +15.2 Bu/A. and corresponded to an economic advantage of +\$80.71/A. Alternatively, correct placement in the offensive zones resulted in yield gains of +5.4 Bu/A. with increased revenue of +\$28.67/A.

Figure 5. also summarizes multi-genetic corn planting performance over the six-year time period of 2018-2023. During this timeframe, multi-genetic corn has offered increased yield gains of +11.1 Bu/A. with additional farm revenue of

+\$48.98/A. in increased revenue. In each zone placement over the last 6 years, only once was the placement incorrect. This track record would suggest an 83.3% success rate for choosing the optimum hybrid placement over 2018-2023 for each high/low yield zone.

Based on this multi-year data, if a grower invested \$1000/row on a 16-row planter for multi-hybrid technology, these types of yield and economic gains would result in return on investment at only 327 acres. These yield results confirm that a multi-genetic system can offer yield advantages and potentially large economic gains if used properly. For this system to work, growers and seedsmen need to work together to place the appropriate genetics on the correct acre and plant at suitable seeding rates.



Corn Leaf Orientation Study

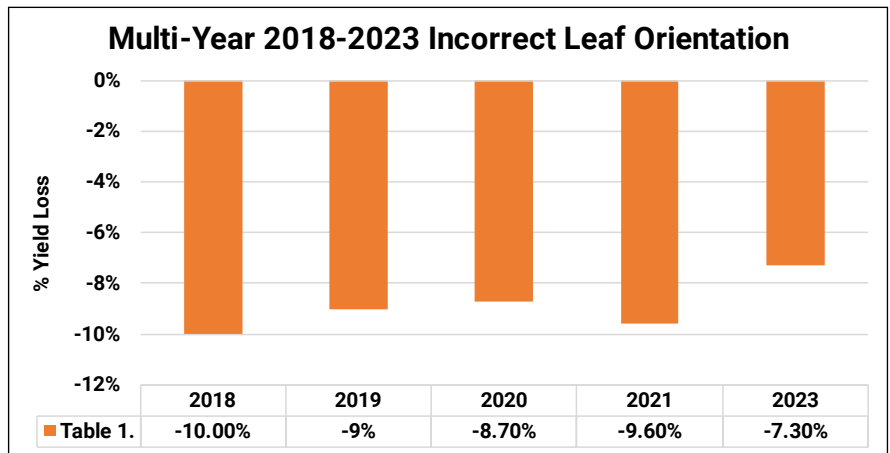
Objective: To study corn leaf orientation within the row and understand the relationship of yield impact of corn leaves being positioned parallel or perpendicular to the row (Figures 1-2). Correct leaf orientation offers benefits of increased light interception, less sunlight to encourage weed suppression, cooler in-canopy temperatures, and moisture preservation.



Figure 1. Correct Leaf Orientation

Figure 2. Incorrect Leaf Orientation

Results: Table 1. illustrates the multi-year results of yield checks at the PTI Farm from 2018 to 2023. Individual ear weight loss associated with incorrect leaf orientation resulted in **-8.92%** yield loss. Table 2. depicts average yield losses of **-17.8 to -22.3 Bu/A.** for each plant with wrong leaf orientation. However, occurrence factors of these incorrectly oriented plants generally range from 20% to 30% of all plant populations. Therefore, actual yield losses from incorrect orientation range from **-3.6 to -6.7 Bu/A.** depending on overall actual corn yield



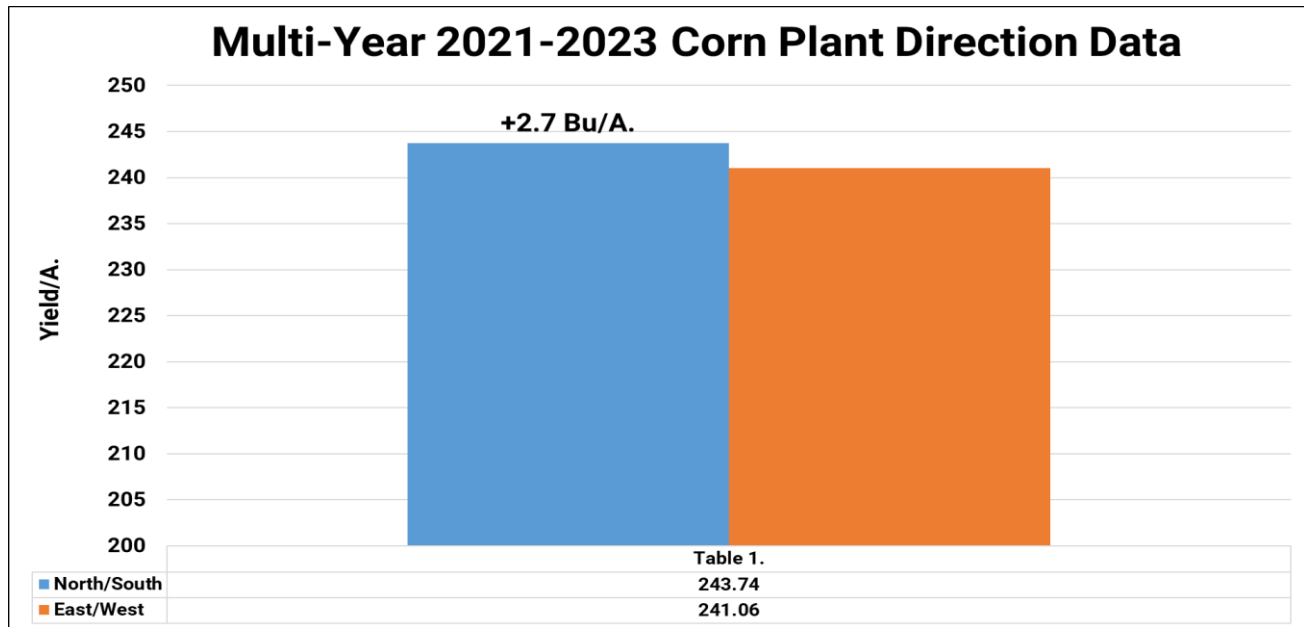
average. Work is being done to establish solutions to help eliminate incorrect leaf orientation. Some of this work identifies seed placement in the seed furrow to manipulate direction of leaf placement. Early studies indicate that incorrect leaf orientation cannot be totally prevented, but trial data does suggest that placing seed in certain positions in the furrow can improve results by +10%. In general, seed tip directional placement has been seen to improve emergence timing, while embryo directional placement potentially may impact leaf orientation.

2018-2023	Table 2.	Occurrence Factor Percentage		
Overall, Corn Yield	Yield Loss	20% Wrong	25% Wrong	30% Wrong
200	-17.8 Bu/A.	-3.6 Bu/A.	-4.5 Bu/A.	-5.4 Bu/A.
225	-20.1 Bu/A.	-4.0 Bu/A.	-5.0 Bu/A.	-6.0 Bu/A.
250	-22.3 Bu/A.	-4.5 Bu/A.	-5.6 Bu/A.	-6.7 Bu/A.

Corn Directional Planting Study

Objective: To study corn directional planting in a standard whole field of corn scenario. Entire fields were planted in a North/South, as well as an East/West fashion to establish data between the two planting directions. Most farmers plant their fields based on the way the field is laid out, the way water flows, or other factors on their individual farms but we wanted to establish if there was a difference in yield from these two directions.

Results: Table 1. illustrates the multi-year results of data at the PTI Farm from 2021 to 2023. Based on these three years of data, we have proved a +2.7 Bu/A. advantage to planting corn in a North/South fashion versus East/West. Some factors that could contribute to this yield advantage are increased light interception.



15" Narrow Row Corn Seeding Rate Study

Objective: This trial evaluates a narrow system of 15" rows with eight seeding rates of 28K, 32K, 36K, 40K, 44K, 48K, 52K and 56K. Two hybrids consisting of Dekalb® 64-22 and Golden Harvest® 10L16 are used to help identify differences in plant type response.



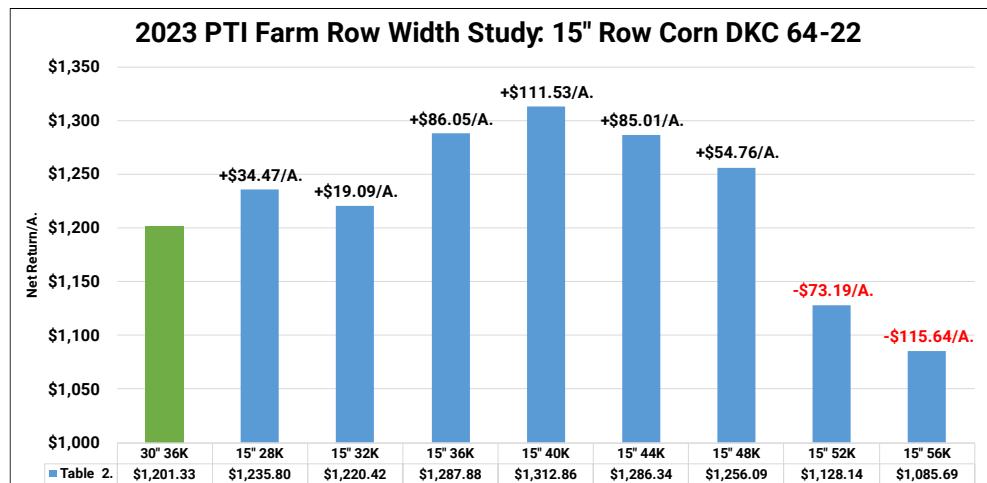
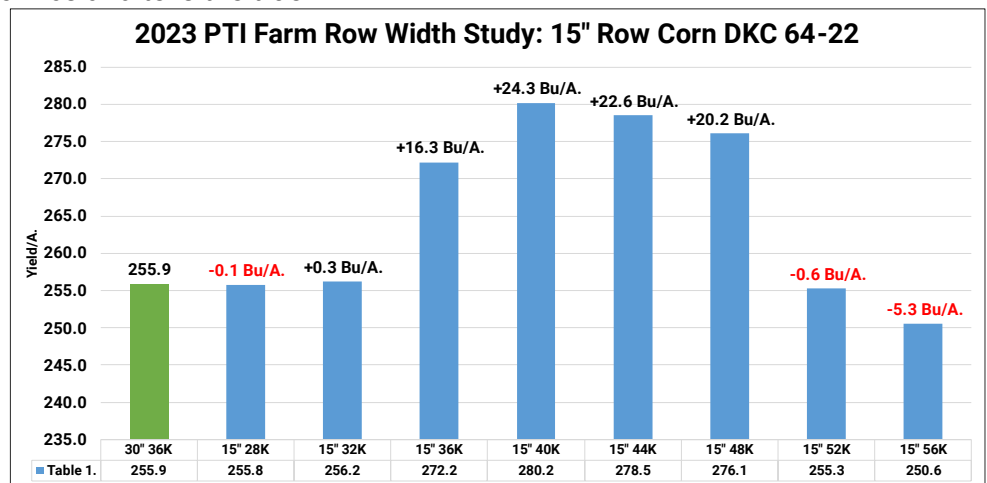
Results:

Table 1. illustrates that Dekalb® 64-22 achieved agronomic optimum yield at the 40K seeding rate at 280.2 Bu/A. Seeding rates of 36K to 48K outperformed 30" row corn at 36K by +16.3 Bu/A. to +24.3 Bu/A.

Table 2. represents economics and tells the true story of which seeding rates offered highest net return. 36K, 40K and 44K seeding rates offered the highest economic returns with increases of +\$85.01, +\$86.05 and +\$111.53/A. over 30" rows.

Pushing seeding rates too high at 52K and 56K proved losses of **-\$73.19/A.** to **-\$115.64/A.**

The lowest seeding rates of 28K and 32K secured intermediate gains of +\$19.09/A. to +\$34.47/A.



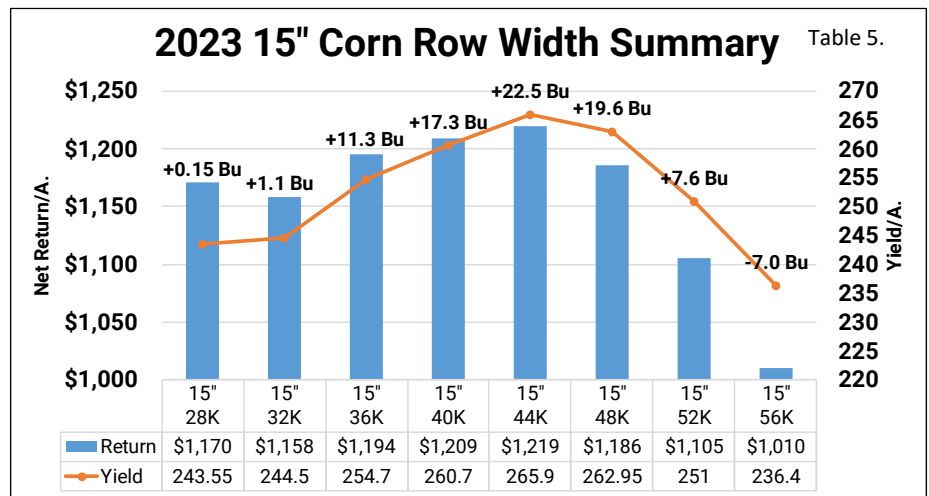
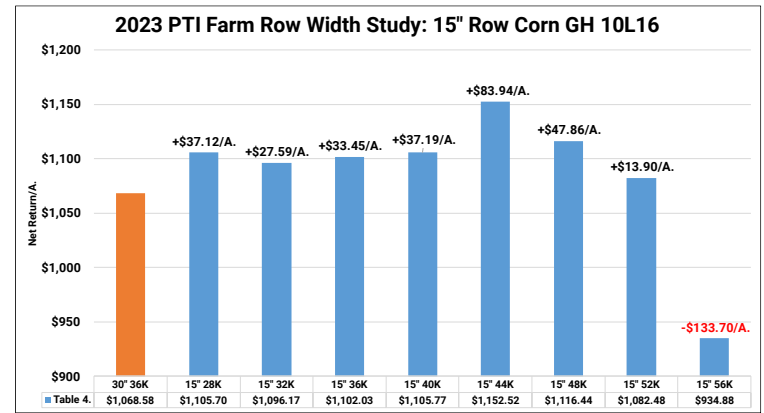
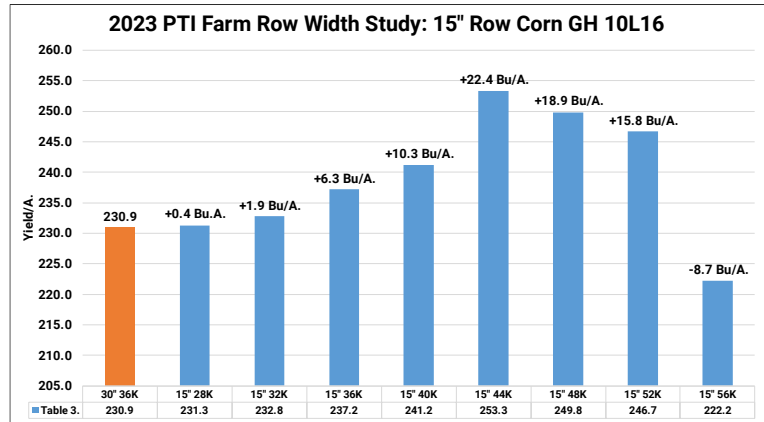
15" Narrow Row Corn Seeding Rate Study Continued

Table 3. illustrates Golden Harvest® 10L16 offered agronomic optimum yield at 44K seeding rates and proved gains of +22.4 Bu/A. over 30" row corn.

Table 4. represents the economics and indicates 44K seeding rates also achieved economic optimum seeding with net returns of +\$83.94/A. Pushing seeding rates to 56K resulted in significant economic losses of **-\$133.70/A.**

Table 5. summarizes both corn hybrids in yield and net return. On average, highest yield and economic return occurred at seeding rates of 36K, 40K, and 44K, with yields ranging from +11.3 Bu to +22.5 Bu/A. over the industry standard of 30" rows.

15" rows performed very well in 2023 with some of its largest yield gains over 30" since our testing program began. This large yield advantage may be reflected upon the severe drought encountered in the month of June. 15" row corn may have had the advantage of quicker crop canopy, cooler soil temperatures and lower weed competition.



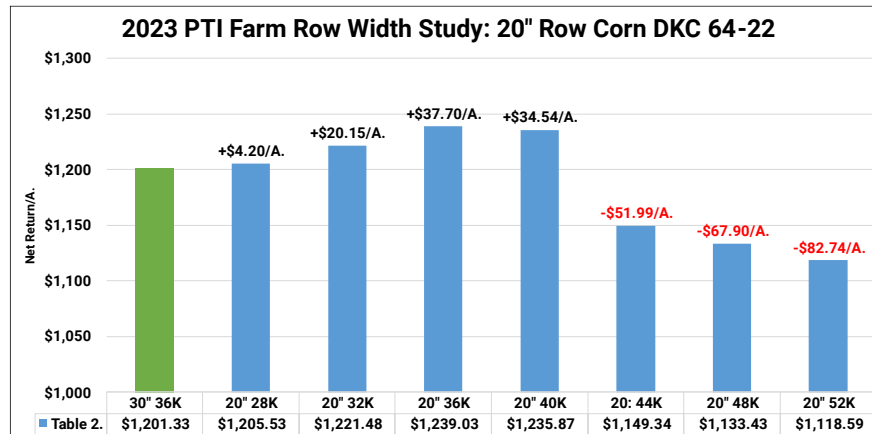
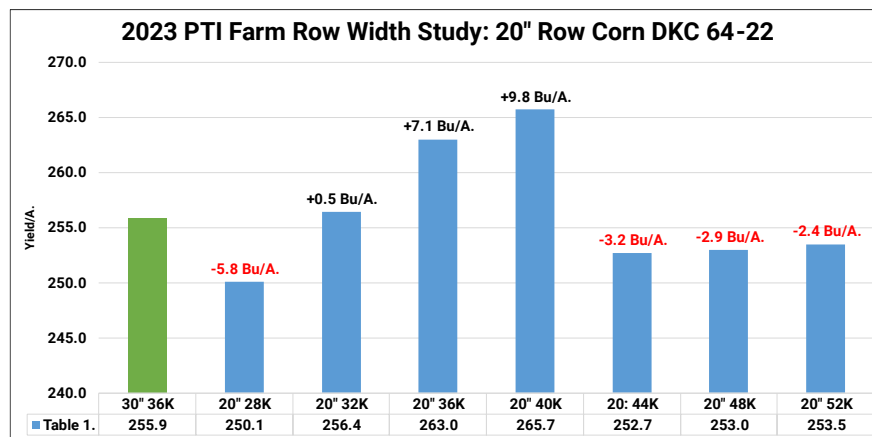
20" Narrow Row Corn Seeding Rate Study

Objective: This trial evaluates a narrow row system of 20" rows with eight seeding rates of 28K, 32K, 36K, 40K, 44K 48K and 52K. Two hybrids consisting of Dekalb® 64-22 and Golden Harvest® 10L16 are used to help identify differences in plant type response.



Results: Table 1. illustrates that Dekalb® 64-22 achieved agronomic yield at the 40K seeding rate at 265.7 Bu/A., offering +9.8 Bu/A. increase over 30" rows at 36K.

Table 2. represents economics and indicates 36K to 40K seeding rates offering largest economic returns at +\$34.54 to +\$37.70/A. over 30" rows at 36K.



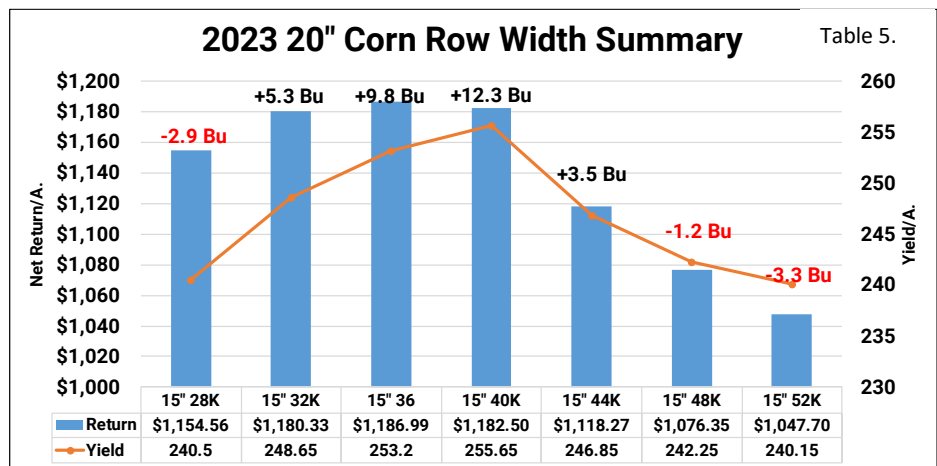
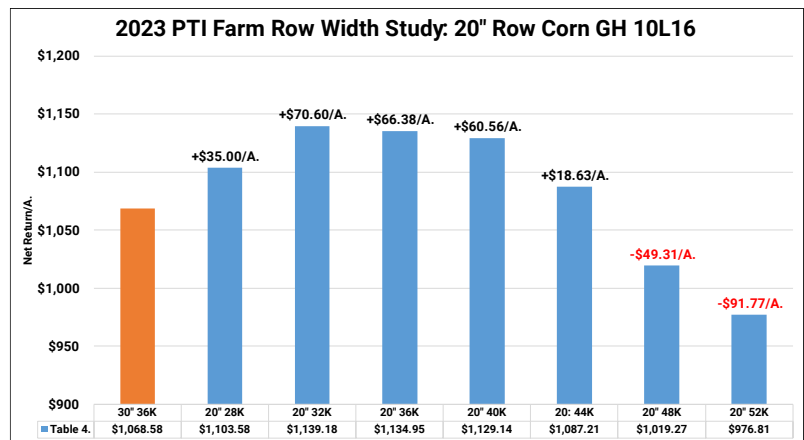
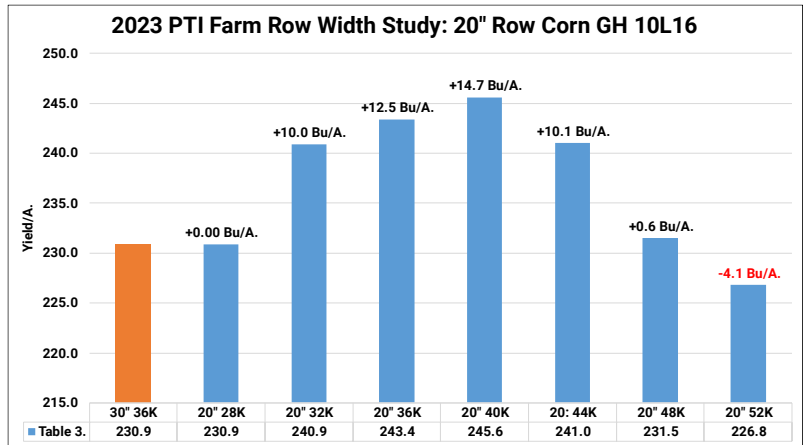
20" Narrow Row Corn Seeding Rate Study Continued

Table 3. illustrates Golden Harvest® 10L16 achieved agronomic optimum yield at the 40K seeding rate at 245.6 Bu/A., with +14.7 Bu/A. yield increase over standard 30" rows at 36K seeding rates.

Table 4. represents economics and indicates 32K seeding rates achieved economic optimum seeding rate, with +\$70.60/A. gains over 30" rows.

Table 5. summarizes both corn hybrids in yield and net return. On average, highest yield and economic return occurred at seeding rates of 36K and 40K, with yields ranging from +9.8 Bu to +12.3 Bu/A. over the industry standard of 30" rows.

20" rows did offer yield gains over and above 30" rows. This yield advantage may be reflected upon the severe drought encountered in the month of June. 20" row corn may have had some advantage of quicker crop canopy, cooler soil temperatures and lower weed competition.



Multi-Year Narrow Corn Row Width Study

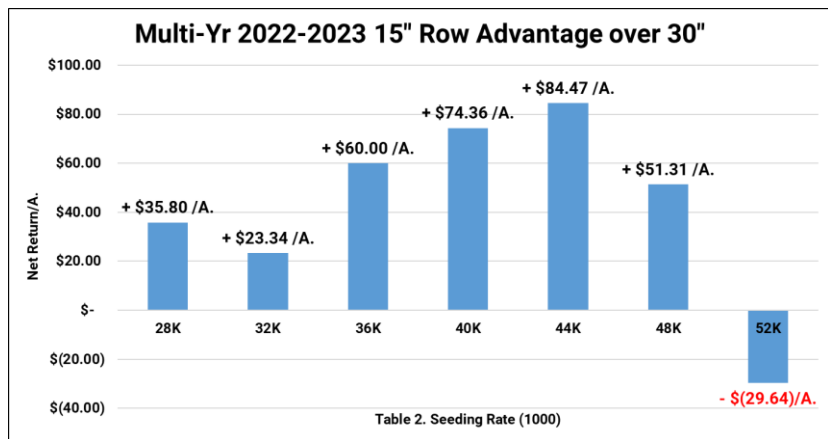
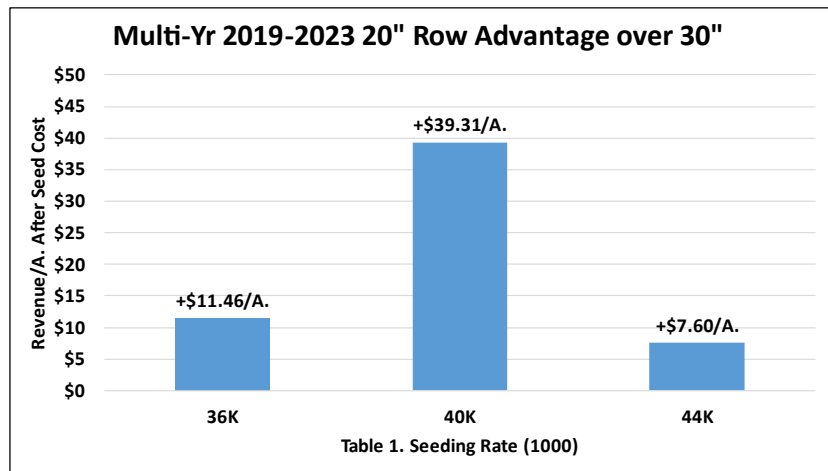
Each year we have thousands of growers that come to the PTI Farm to have a conversation about agronomics. One question we talk about often is corn row width. Many farms today that are on 30" corn rows, say they switched from wide 38" or 36" wide rows back in the early 70's. If this is the case, growers have been implementing 30" row corn systems for nearly 50 years. The question now is, has 50 years been long enough to do the same thing over and over, or is time now for a change to another system that could offer higher yields and profitability?

The question comes down to this; What revenue gain would cause a farmer to run to their local equipment dealer and convert their planters, harvest equipment, tractor tires, side-dress equipment, or even over-all management to narrow rows?

Table 1. illustrates multi-year data over the timeframe of 2019-2023 and reveals 20" rows offering an overall economic advantage of +\$38.86/A. over 30" rows planted at 36K.

Table 2. illustrates multi-year data over the timeframe of 2022-2023 and reveals 15" rows offering highest economic advantage of +\$60/A. to +\$84.47/A. over 30" rows planted at 36K.

Data suggests that 15" rows have proven to offer much higher net return than that of 20" rows. In fact, 15" corn has offered yield 1.5X to 2.2X to that of 20" rows. One thing is true, narrow rows are offering more overall revenue than 30" rows, however it is uncertain on how high this number needs to be in order to get a grower to switch from 30" rows to narrow?



20" Narrow Row Corn At-Plant Nitrogen Study

Objective: This study evaluates the yield and economic impact adding at-plant nitrogen in a narrow row 20 inch corn program.

For many growers, nitrogen management may be difficult in narrow row corn due to row width, tire size, and equipment.

This study evaluates adding an at-plant Conceal® dual band nitrogen application to help improve nitrogen management in narrow 20" corn rows.

This study evaluates two nitrogen programs:

- ✓ 50% N 32% UAN Weed-n-Feed + V10 50%N Side-dress
- ✓ 25% N with 32% UAN Weed-n-Feed + 25% N at-plant Conceal® at-plant N + V10 50% Side-dress

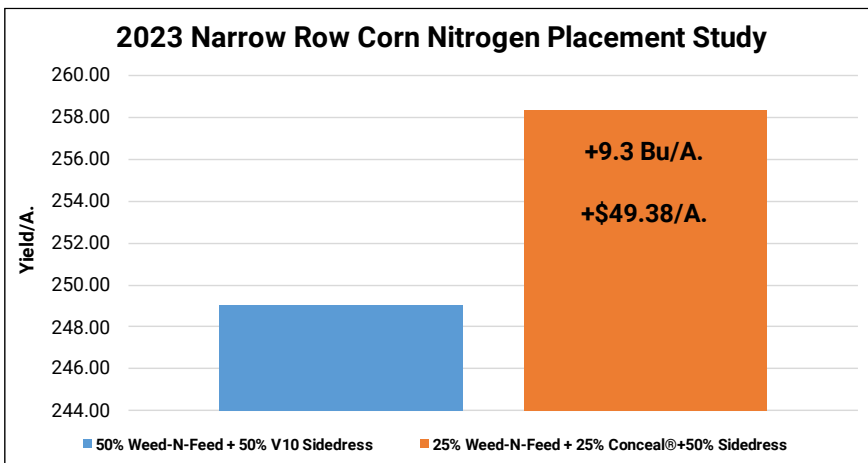


Figure 1. Conceal At-Plant Nitrogen



Results: Adding an at-plant nitrogen placement resulted in yield gains of +9.3 Bu/A., creating an additional gross revenue of +\$49.38/A.

20" vs 30" Short Corn Row Width/Seeding Rate Study

Objective: To evaluate yield and economic impact of planting short corn hybrids in both 30" and 20" rows, planted at seeding rates of 34K, 42K, and 50K.

Short corn is a new platform of corn that is designed to be short in stature. Overall plant height is decreased due to node "stacking" from ear placement to the soil surface. Short corn is designed to be planted at higher seeding rates, due to its lower biomass and plant architecture/design.

Due to the plant design, it is recommended to plant short corn hybrids at higher seeding rates near 40K. With 30" row width being the industry standard, this study's goal is to help determine if short at higher seeding rates is acceptable in wide row 30", or will growers need to shift towards narrow (20" or 15") in the future in order to optimize yield and profitability.

Figure 1. Short Corn Node Stacking



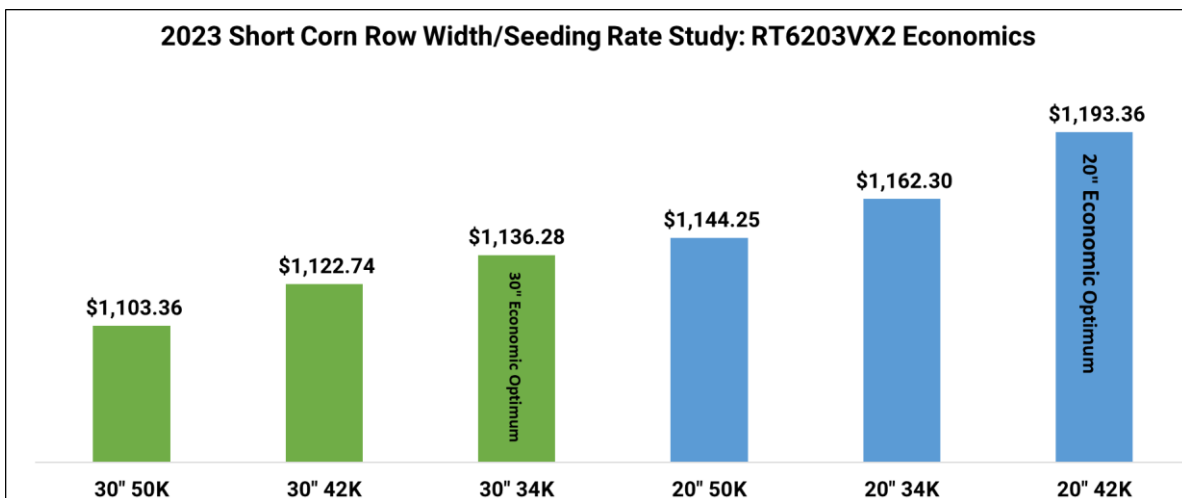
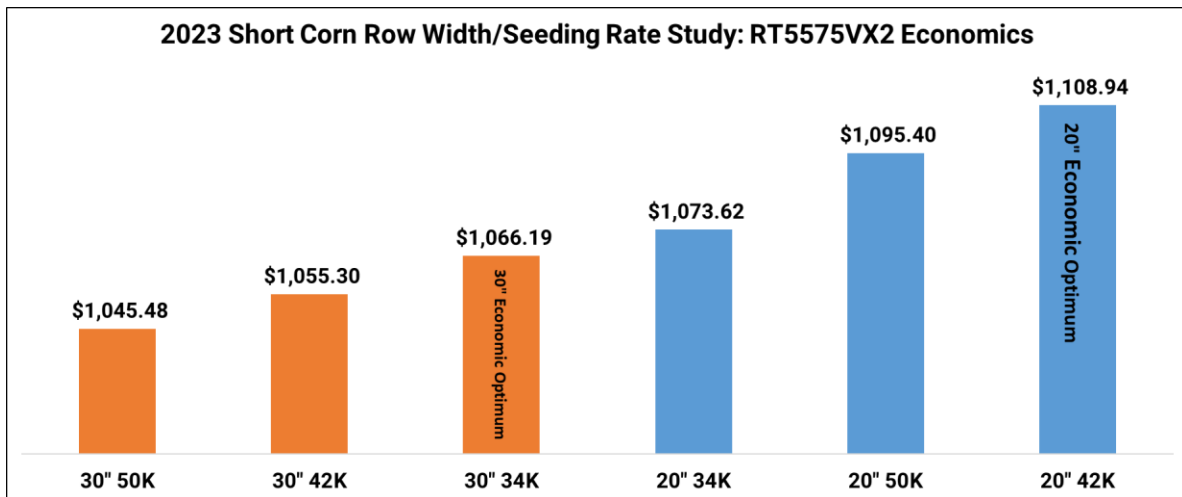
Figure 2. Short Corn Height Difference



20" vs 30" Short Corn Row Width/Seeding Rate Study

Results: RT5575VX2 resulted in the highest net return when planted in narrow 20" rows at 42K seeding rates. All 20" row seeding rates out-performed the 30" rows on an economic basis. However, in 30" rows, the lowest 34K seeding rate achieved economic optimum for that row width system. Just comparing each row width's economic seeding rate, 20" rows tallied additional net revenue of +\$42.75/A.

RT6203VX2 tallied its highest net revenue planted in narrow 20" rows at the 42K seeding rate. As with RT5575VX2, all 20" row seeding rates outperformed the 30" rows on an economic basis. 30" rows achieved its economic optimum seeding rate at the lower 34K seeding rate. Between the two-row width's, 20" rows resulted in additional net revenue of +\$57.08/A.



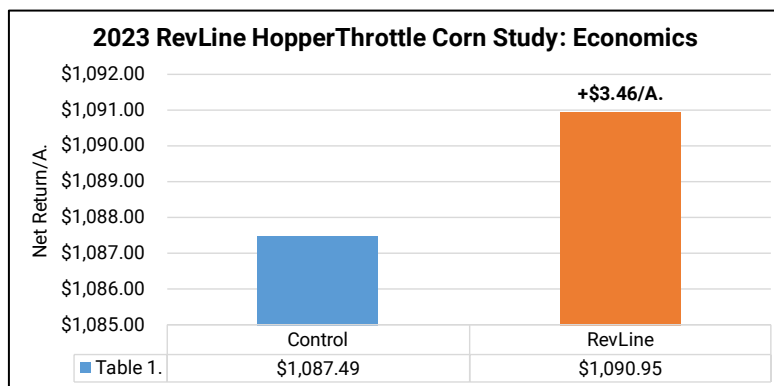
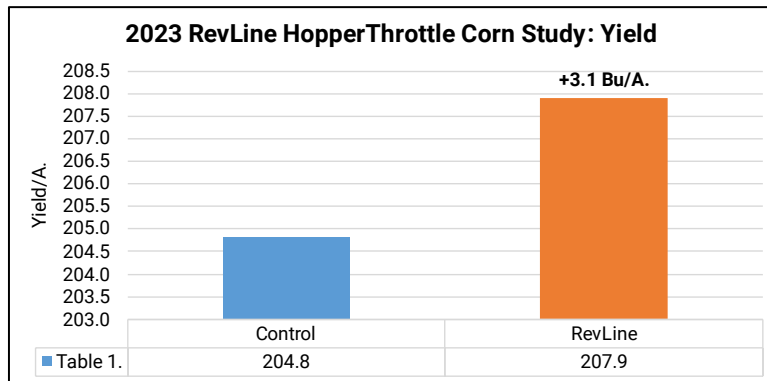
REVLIN[®] HOPPER THROTTLE[™] Hopper Box Treatment Study

Objective: To evaluate yield and net return of REVLIN[®] HOPPER THROTTLE[™], a talc graphic/micronutrient planter box treatment.

HOPPER THROTTLE[™] is an 80/20 talc graphic blend for planters that also contains Manganese, and Zinc. It places essential nutrition, flow agents, and crop enhancement components directly on the seed to aid in singulation and improve seedling vigor and growth.



Results: HOPPER THROTTLE[™] hopper box treatments offered average yield gains of +3.1 Bu/A. with a positive net return on investment of +\$3.46/A.



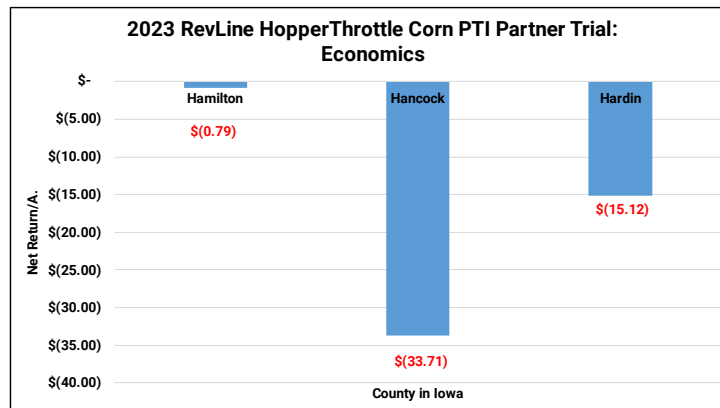
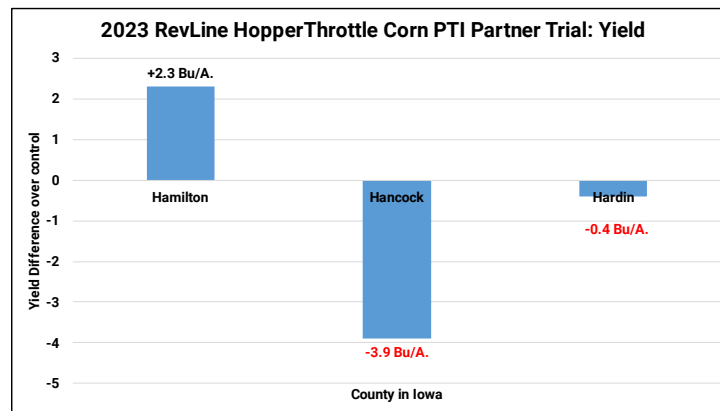
Planting Date: May 10th Hybrid: GH 15J91 Population: 26K Row Width: 30" Rotation: CAB Corn Price: \$5.31 HOPPER THROTTLE: \$13.00/A. Talc/Graphite: \$0.15/A.

REVLIN® HOPPER THROTTLE™ Hopper Box Treatment Iowa Trial

Objective: To evaluate yield and net return of REVLIN® HOPPER THROTTLE™. This trial was done as a 3 location PTI partner trial, implemented by Arnold Farms located in Hamilton, Hancock and Hardin County, Iowa.

HOPPER THROTTLE™ is an 80/20 talc graphic blend for planters that also contains Manganese, and Zinc. It places essential nutrition, flow agents, and crop enhancement components directly on the seed to aid in singulation and improve seedling vigor and growth.

Results: HOPPER THROTTLE™ treatments offered average yield gains of **-0.67 Bu/A.** with a negative return on investment of **-\$16.54/A.**



Rosens StrideBio™ Hopper Box Treatment Study

Objective: To evaluate yield and net return of Stride Bio™, a talc graphic/micronutrient planter box treatment.

Stride Bio is an 80/20 talc graphic blend for planters that also contains Calcium, Magnesium, Sulfur, Iron, Manganese, and Zinc. It places essential nutrition, flow agents, and crop enhancement components directly on the seed to aid in singulation and improve seedling vigor and growth.



Results: Stride Bio™ hopper box treatments offered average yield gains of +3.8 Bu/A. with a positive net return on investment of +\$17.03/A.

As a second year product study, 2-yr yield gains average +3.3 Bu/A. with corresponding economic gains of +\$15.33/A.

This trial was done as a PTI partner trial, implemented by Shronk Farms in Hillsboro, Texas.

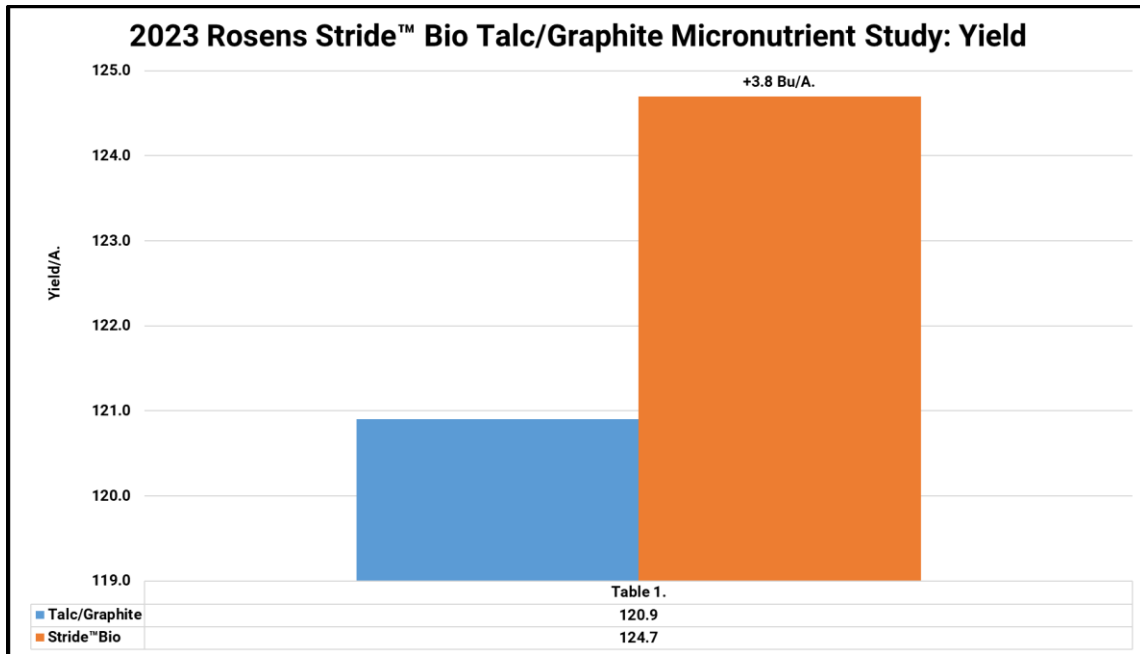
Guaranteed Analysis
0-0-0

Calcium (Ca).....	1.0%
Magnesium (Mg).....	0.5%
Sulfur (S).....	4.0%
4.0% Combined Sulfur	
Iron (Fe).....	0.1%
0.0% Water Soluble Iron	
Manganese (Mn).....	4.0%
4.0% Water Soluble Manganese	
Zinc (Zn).....	10.0%
4.0% Water Soluble Zinc	

Derived from: Dolomitic Limestone, Iron Oxide, Manganese Sulfate, Zinc Sulfate, Zinc Oxide.

Also contains non-plant food ingredients: Talc & Graphite in an 80/20 ratio.

GENERAL INFORMATION
Stride Bio places essential nutrition, flow agents, and crop enhancement components directly on the seed to aid in singulation and improve seedling vigor and growth. Stride Bio is compatible with fungicide, insecticide seed treatments and inoculants, but does not replace those products. Stride Bio replaces the need for adding talc or graphite.



Rootella® F Hopper Box Corn Inoculant Study

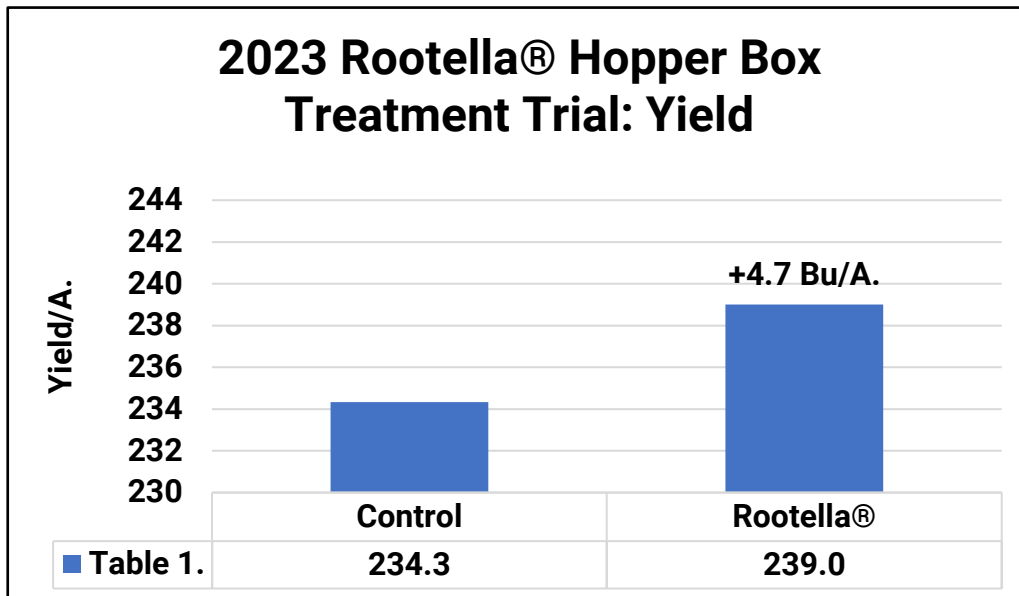
Objective: To evaluate yield and net return of Rootella® F planter box treatment.

Rootella® F concentrated fine powder mycorrhizal inoculant effectively inoculates plants with vigorous endomycorrhizal fungi. The mycorrhizal inoculation improves plant nutrient uptake and has been proven to improve crop yield; reduce fertilizer, compost, and irrigation requirements; and increase plant durability under stress. Rootella® F mycorrhizal inoculants are ideal for manual mixing with seeds. This product formulation clings to seeds and lends itself well to the planter box applications.



Results: Hopper box treatments of Rootella® resulted in yield gains of +4.7 Bu/A. and offered economic gains of +\$18.46/A. 2-Yr data has proven yield advantage of +3.3 Bu/A. with net returns of +\$14.54/A.

This trial was done as a PTI partner trial, implemented by Pfiefer Farms in Mazon, IL.

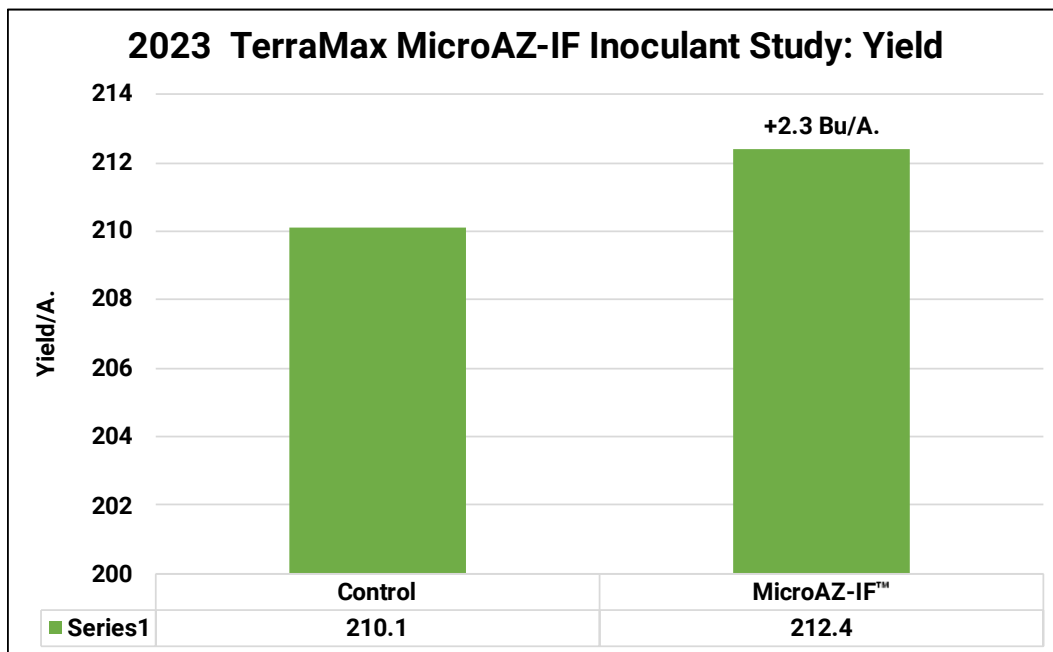


TerraMax Hopper Box Corn Inoculant Study

Objective: To evaluate the use of MicroAZ-ST Dry™, a seed treatment inoculant that aids with bacterial growth and survival. MicroAZ-ST Dry™ is a Azospirillum based product that help microbes fix atmospheric nitrogen to a usable form and gather more nitrogen from the soil. Once the bacteria attach to the roots it helps to stimulate root development to improve nutrient uptake.

Results: MicroAZ-ST Dry™ treatments resulted in yield gains of +2.3 Bu/A. At a \$5.31 corn commodity price and a product cost of \$5.91/A., MicroAZ-ST Dry™ offered economic gains of \$6.30/A.

Multi-year data from 2022-2023 show that MicroAZ-ST Dry™ treatments have an average yield gain of +2.7 Bu/A. and an economic gain of +\$6.48/A.



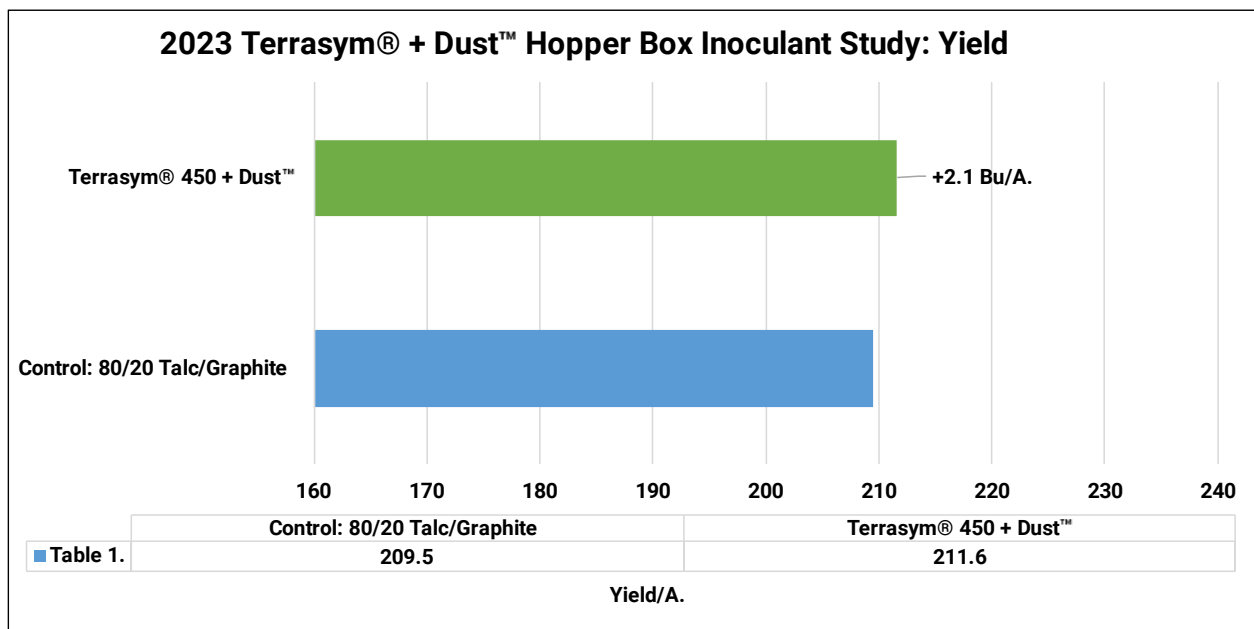
Planting Date: May 10th Hybrid: GH 15J91 Population: 36K Row Width: 30" Rotation: CAB Corn Price: \$5.31 MicroAZ-ST: \$5.91/A.

Terrasym® 450 + Dust™ Hopper Box Study

Objective: To evaluate the use of Terrasym® 450, a unique strain of beneficial microbes called pink pigmented facultative methylotrophs (PPFMs), specially selected for use in corn.

NewLeaf Symbiotics® and Low Mu Tech™ have combined proprietary Terrasym® microbial technology with a micro-plastic free, patented DUST™ seed flow lubricant. Terrasym® 450 + DUST™ for corn is designed to improve seed lubrication and seed flow during planting and deliver improved nutrient uptake leading to robust early season root development, enhanced tolerance of abiotic stress throughout the growing season, and higher yields at harvest.

Results: Hopper box treatments of Terrasym® 450 + Dust™ resulted in yield gains of +2.1 Bu/A. over standard 80/20 talc graphite applications. At a \$5.31 corn commodity price and a product cost of \$6.00/A., economics netted +\$5.30/A. 2022-2023 data averages +1.41 Bu/A. yield increase with net returns of +\$2.65/A.



Planting Date: May 15th

Hybrid: DKC 59-82VTDoublingPro

Population: 36K Row Width: 30"
Terrasym 450+Dust: \$6/A

Rotation: CAB

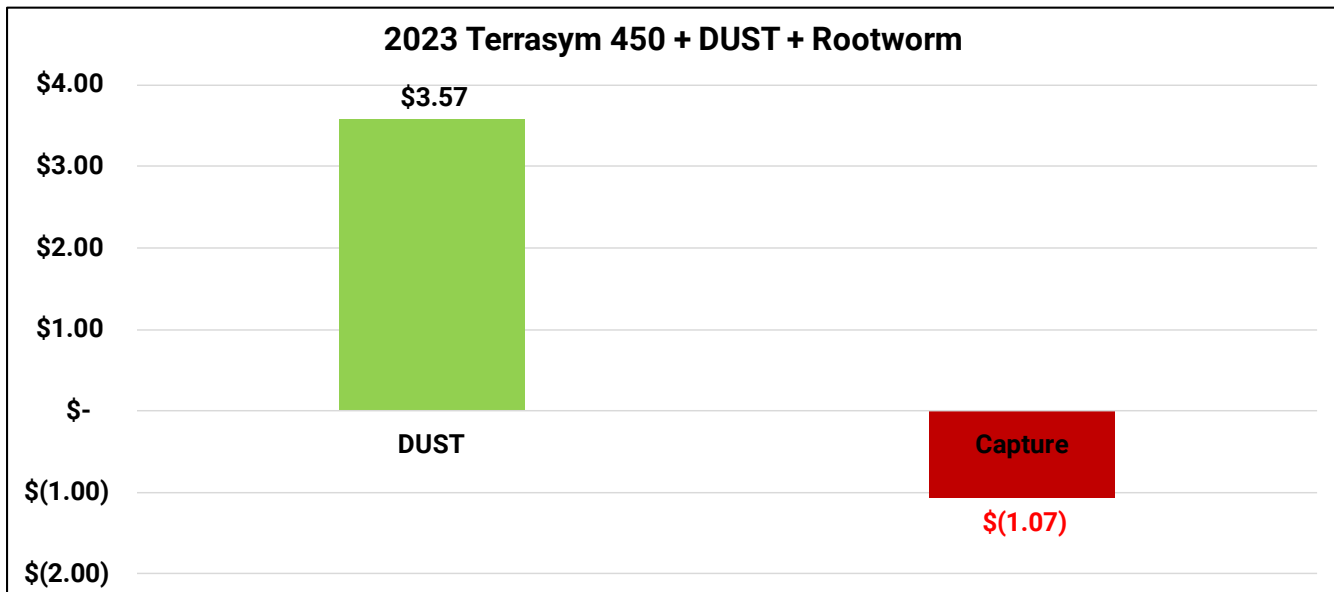
Corn Price: \$5.31

Terrasym®450 + Dust™ + CRW Mitigation Hopper Box Study

Objective: To evaluate the use of Terrasym® 450 + Dust™ + TS210™ (CRW Mitigation BioPesticide) compared to a traditional insecticide treatment. TS210 triggers the plants' defenses when it's applied to the seed in turn has a decrease in Corn Rootworm larva root feeding. When there is root damage due to feeding TS210 helps increase root regrowth.

Terrasym® 450 + Dust™ + TS210 combined help to improve seed lubrication and seed flow during planting and deliver improved nutrient uptake leading to robust early season root development, protect against Corn Rootworm larva feeding and increase root regrowth, enhanced tolerance of abiotic stress throughout the growing season, and higher yields at harvest.

Results: Hopper box treatments of Terrasym®450 + Dust™+ TS210 resulted in yield gains of +3.45 Bu/A. over the control applications. At a \$5.31 corn commodity price and a product cost of \$14.75/A., economics netted +\$3.57/A. where a traditional insecticide treatment was used it resulted in a net loss of **-\$1.07/A.**



Planting Date: May 15th

Hybrid: DKC 59-82VTDoubePro

Population: 36K

Row Width: 30"

Rotation: CAB

Corn Price: \$5.31

Terrasym450+Dust+ TS210: \$14.75/A

Capture: \$18.06/A.

Broadcast vs Banding Dry Fertilizer Study

Objective: To evaluate yield and economics of traditional broadcast applications of dry fertilizer compared to 8" deep high concentrated strip-till banding.

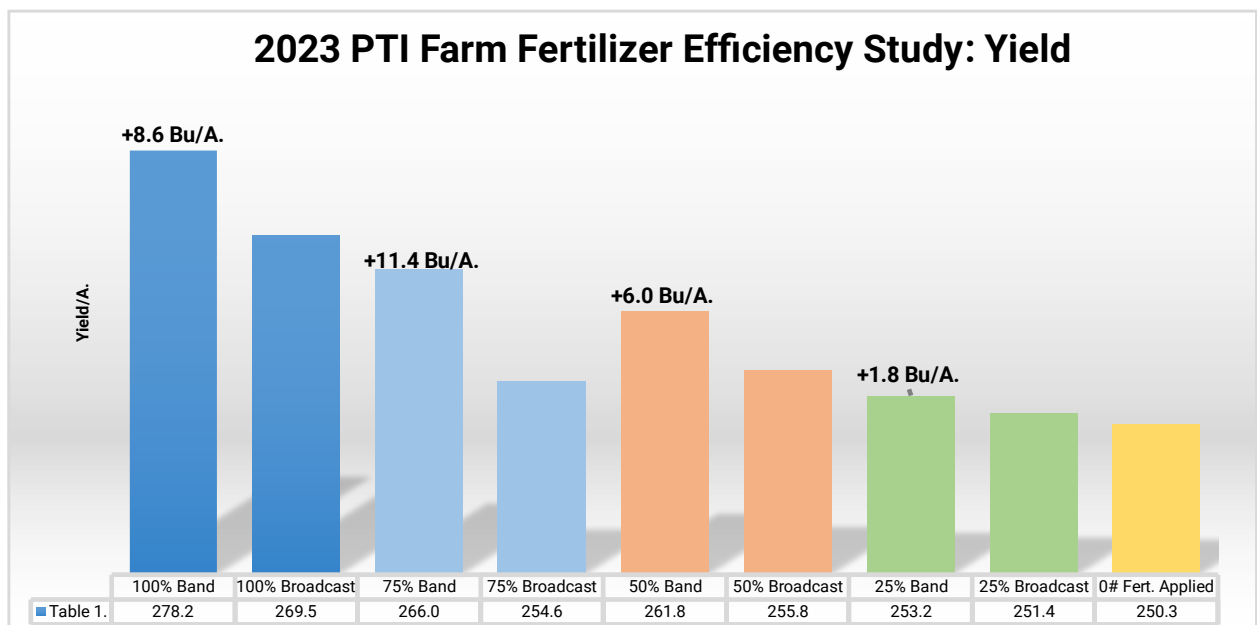
Based upon soil test results and yield goals of 250 Bu/A. corn in a corn/soybean non-irrigated rotation, a broadcast surface application was made with a traditional spinner truck (Figure 1). Using the same fertilizer rates, a strip-till bar was used to place fertilizer in high concentrated strips 8" deep on 30" corn rows (Figure 2). Corn was then planted directly into the strips above the 8" fertilizer placement. A KUHN® Krause® 1200 Gladiator® pulling a Montag® Equipment 2208 Gen 2 fertilizer cart was used to implement this testing program for 2023.

Results Table 1. illustrates banded fertilizer outperformed broadcast at every efficiency rate. 100% rates offered +8.6 yield increases, 75% at +11.4 Bu/A., 50% at +6.0 Bu/A. and 25% banded rates at +1.8 Bu/A.

Figure 1. Broadcast Dry Fertilizer



Figure 2. Strip-Till Banded Fertilizer



Broadcast vs Banding Dry Fertilizer Study Continued

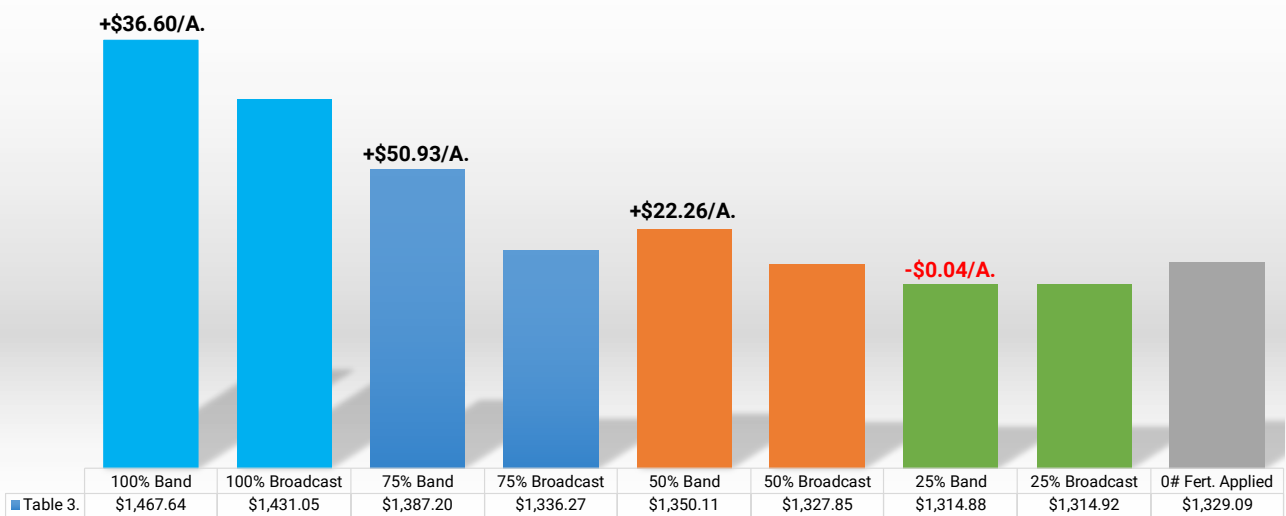
Using University of Illinois Machinery Cost Estimates in Table 2., strip-till resulted in additional costs of +\$9.60/A. in comparison to a conventional tillage program. Using this cost scenario, Table 3. illustrates the economic impact. 100% banded rates of fertilizer offered net revenue gains on +\$36.60/A., while 75% banded rates offered overall highest efficiency of +\$50.93/A. The two lowest rates of 50% and 25% at +\$22.26/A. and **-\$0.04/A.** respectively.

Table 2. University of IL Machinery Cost Estimates

Tillage Practice	Category	Cost
Conventional Till	Soil Finisher	\$ 14.60
	Plant	\$ 21.40
	Fertilizer Spread	\$ 8.00
	Total:	\$ 44.00
Strip Till	Strip	\$ 25.90
	Burndown	\$ 6.30
	Plant	\$ 21.40
	Total:	\$ 53.60



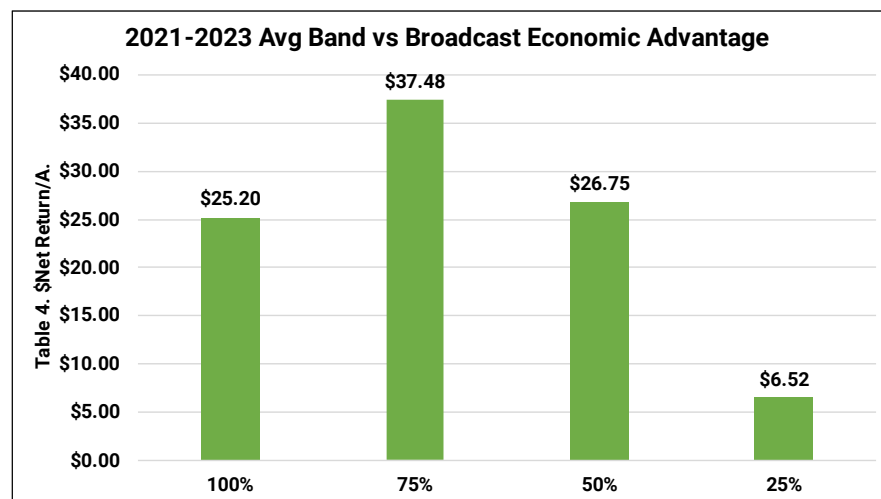
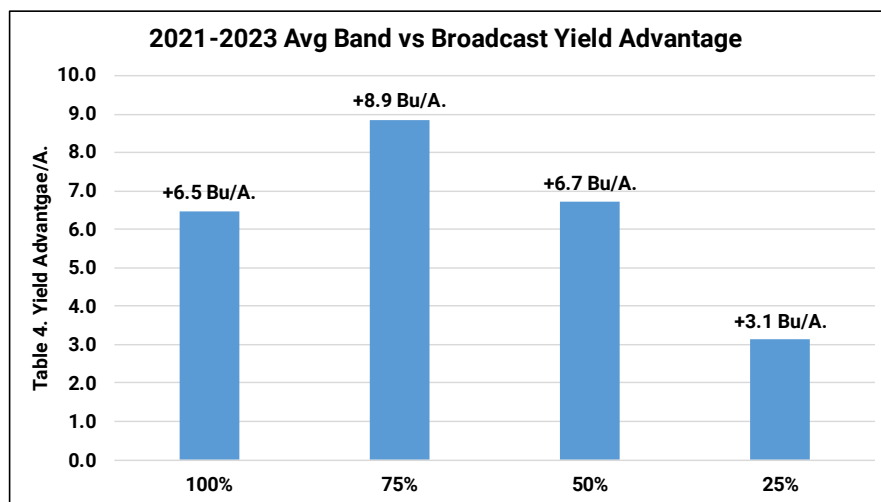
2023 Corn Band vs Broadcast Fertilizer Study: Economics



Broadcast vs Banding Dry Fertilizer Study Continued

Table 4. illustrates multi-year data from the PTI Farm over the years 2021, 2022 and 2023. Over this timeframe, banded dry fertilizer has resulted in the highest average yield gains at the 75% fertilizer rate, while 100% and 50% at +6.5 to +6.7 Bu/A. respectively. Reduced rates of 25% offered lowest gains of the study at +3.1 Bu/A.

Table 5. reflects the economics over the same 3-year time period. 75% rates has offered highest net returns at +\$37.48/A., while 100% and 50% rates just behind at +\$25.20 and +\$26.75/A. 25% rates proved lowest returns at +\$6.52/A.



Corn Fertilizer Rate Efficiency Study

Objective: To evaluate varying rates of dry fertilizer to evaluate agronomic yield and economic optimums.

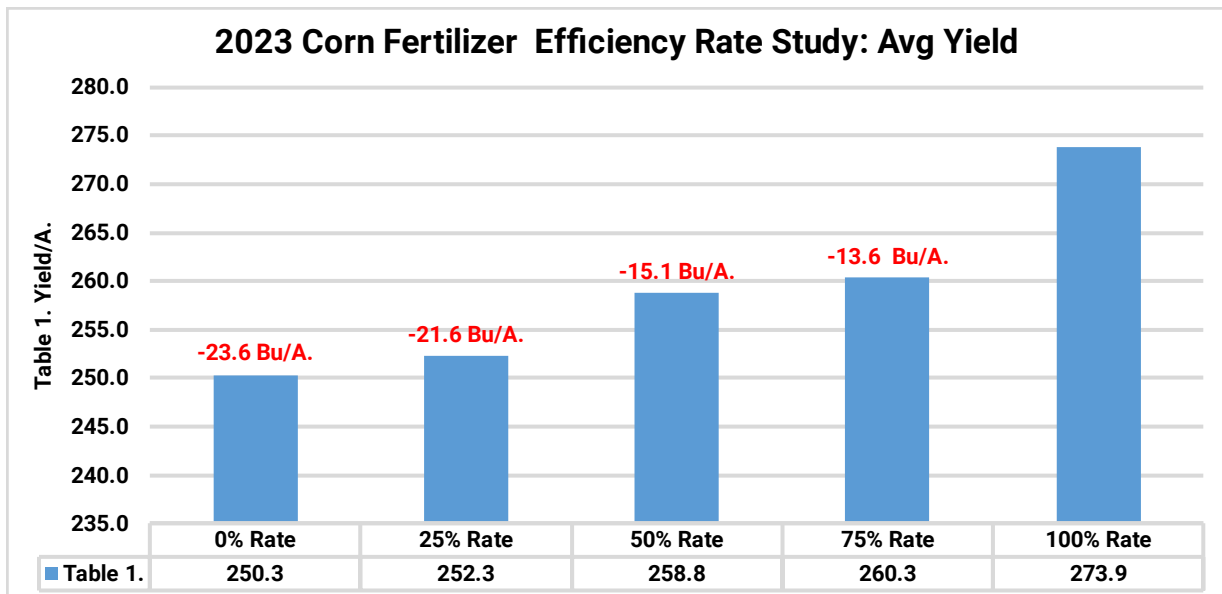
Soil tests were pulled in the Fall of 2022 and recommendations were generated by a local soil test lab using University of Illinois fertility standards. Based on these results, a 100% rate of fertilizer was established for 250 Bu/A. corn in a corn/soybean crop rotation. 100% rates of DAP (18-46-0) and Potash (0-0-60) were then evaluated compared to lower rates of 75%, 50%, 25%, and 0%. These rates were applied in both a traditional broadcast, as well as a banded application and averaged overall both scenarios.

Results Table 1. illustrates yield performance of each individual rate of fertilizer. Highest yield (Agronomic Yield) was obtained at the 100% rate, while every lower rate suffered yield loss. Cutting fertilizer to 75% rates resulted in losses of **-13.6 Bu/A.**, 50% at **-15.1 Bu/A.**, 25% at **-21.6 Bu/A.**, and 0% rates at **-23.6 Bu/A.**

Figure 1. Traditional Broadcast Fertilizer

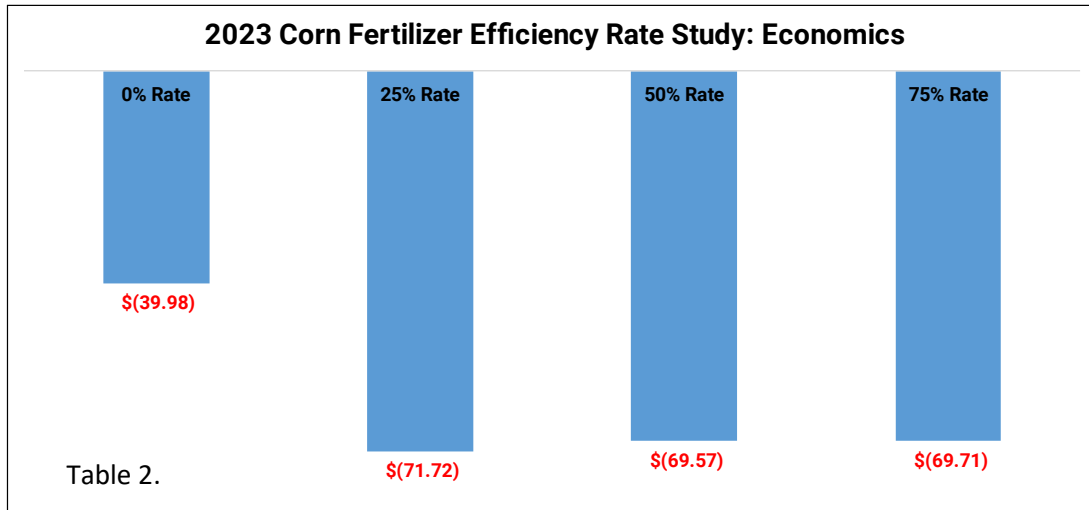


Figure 2. Strip-Till Banded Fertilizer

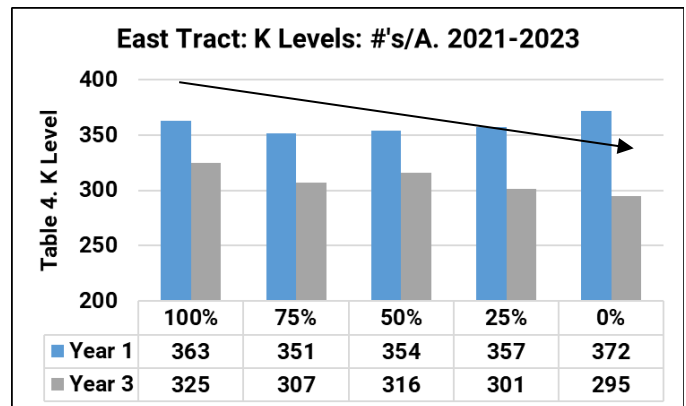
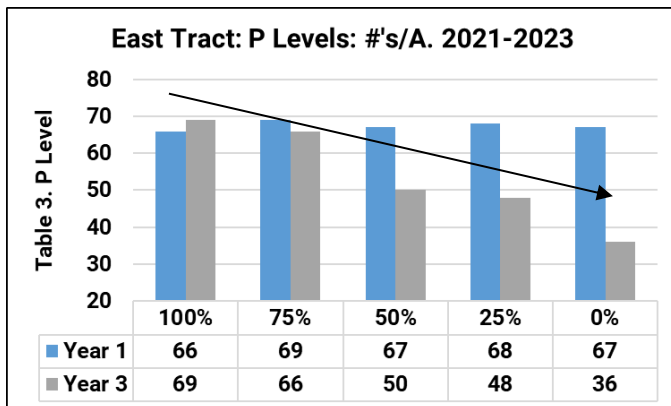


Corn Fertilizer Rate Efficiency Study Continued

Table 2. below indicates that economic optimum occurred at the 100% fertilizer rate, as all lower rates of fertilizer generated negative losses. All 25% to 75% reductions proved economic losses ranging near **-\$70/A.**, however 0% rates proved lower losses of only **-\$39.98/A.** due to no actual fertilizer cost factored into net return.



This study is designed as a 10-yr study to look at a long-term approach of evaluating fertilizer performance, cost of fertilizer, and overall soil test levels. 2023 was our 3rd year of this long-term study and proved to be the first year where fertilizer rate reductions did not offer higher economic returns. Since soil samples are taken annually, it gives us the ability to monitor soil test levels at each fertilizer rate over time. Tables 3-4. summarize soil test P and K levels from our first soil test in year 1, compared to new soil test in 3rd year (2023).



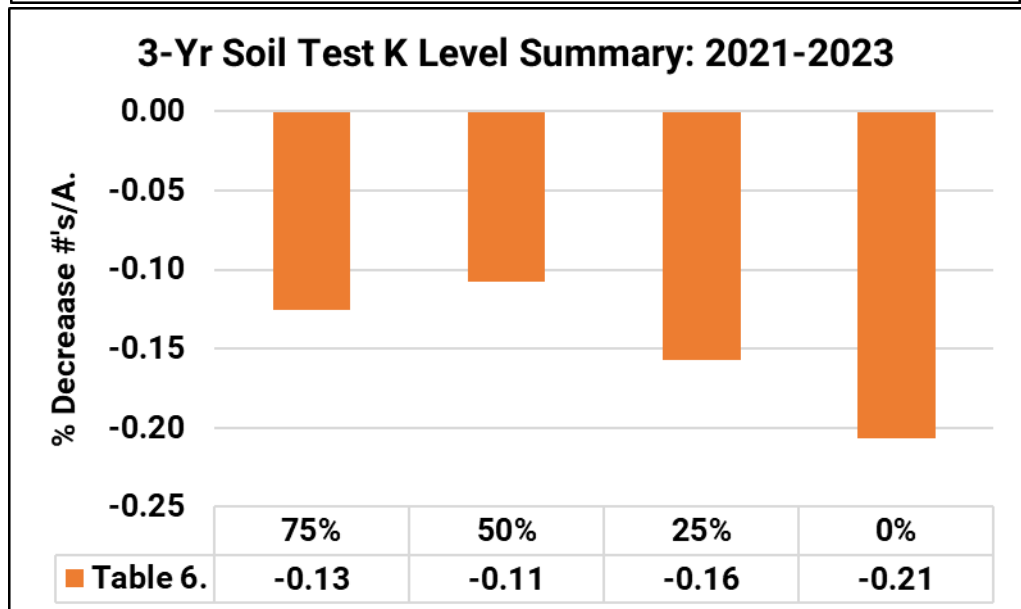
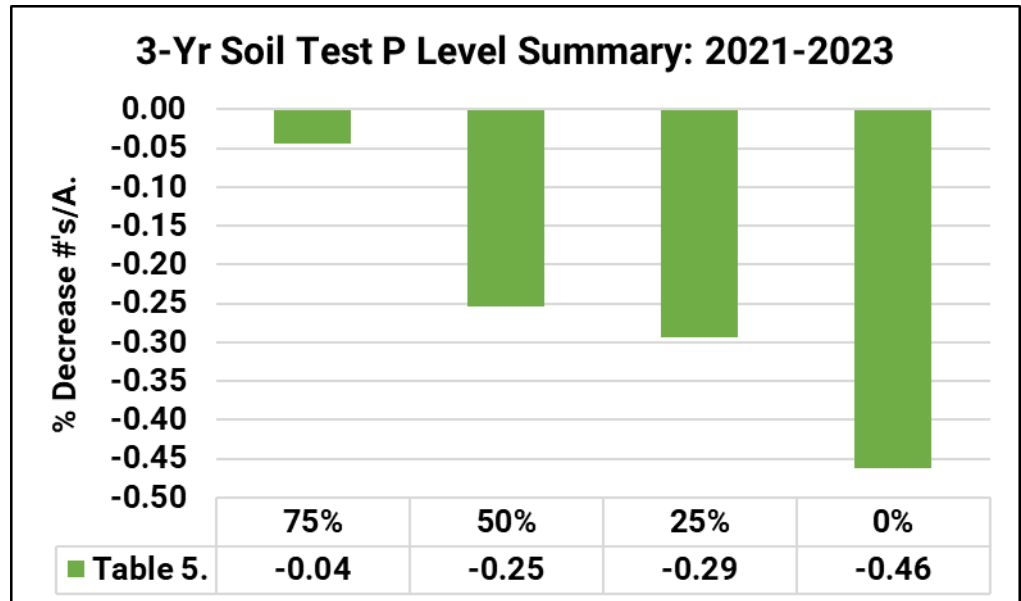
Corn Fertilizer Rate Efficiency Study Continued

Table 5. shows soil test P levels have held within **-4%** over the 3-yr time period, however **-25-29%** reductions in soil test P were seen at 50% to 75% rates. 0% rates resulted in the highest losses at **-46%** deficit.

Table 6. shows soil test K levels, proving much lower deficit reductions compared to that of soil test P. 0% rates resulted in the highest deficit at **-21%**, while 75%,50%, and 25% fertilizer rates proved **-11%** to **16%** lowering of soil test K.

These reductions in soil test levels most likely are the reason for lower yields in

2023. In 2021-2022, fertilizer rate reductions offered higher net returns that of 100% recommended rates of fertilizer. However, as soil test levels have been diminished or “mined”, yield deficit is beginning to occur. Two years of rate reductions and savings of fertilizer worked agronomically and financially, especially with higher actual fertilizer prices. Is it possible that by year 3, we drew soil test levels low enough to drive yield lower? Since this a 10-yr study, it will be interesting to evaluate this over the next 7 years.



Broadcast vs Banding Rate Efficiency Study

Objective: This study evaluates yield and economics of traditional broadcast applications of dry fertilizer compared to concentrated strip-till bands applied 8" in depth under the corn row. The goal of this study is to answer the question; "If I band dry fertilizer versus broadcast applying, can I use a lower rate of fertilizer without sacrificing yield and profitability"?

Based upon soil test results (Fall 2022) and yield goals of 240 Bu/A. corn in a corn/soybean rotation, dry fertilizer was applied in a traditional broadcast surface application as a spinner truck (Figure 1).

To study placement efficiency, using the same fertilizer rates, a strip-till bar was used to place fertilizer in high concentrated strips 8" deep on 30" corn rows (Figure 2). Corn was then planted directly into the strips above the 8" fertilizer placement.

A KUHN® Krause® 1200 Gladiator® pulling a Montag® Equipment 2208 Gen 2 fertilizer cart was used to implement this testing program for 2023.

To address, rate efficiency, fertilizer was applied at the following rate structure in both strip-till bands and broadcast applications:

- 100% Rate
- 75% Rate,
- 50% Rate
- 25% Rate
- 0% Rate

Figure 1. Broadcast Dry Fertilizer



Figure 2. Strip-Till Banded Fertilizer 8" in Depth



Figure 3. Gladiator® Strip-Till Unit with Montag® Fertilizer Cart

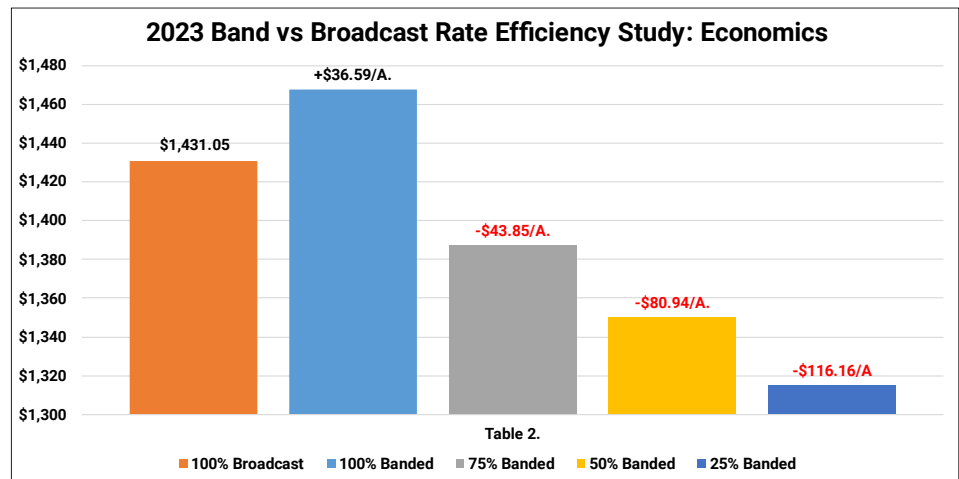
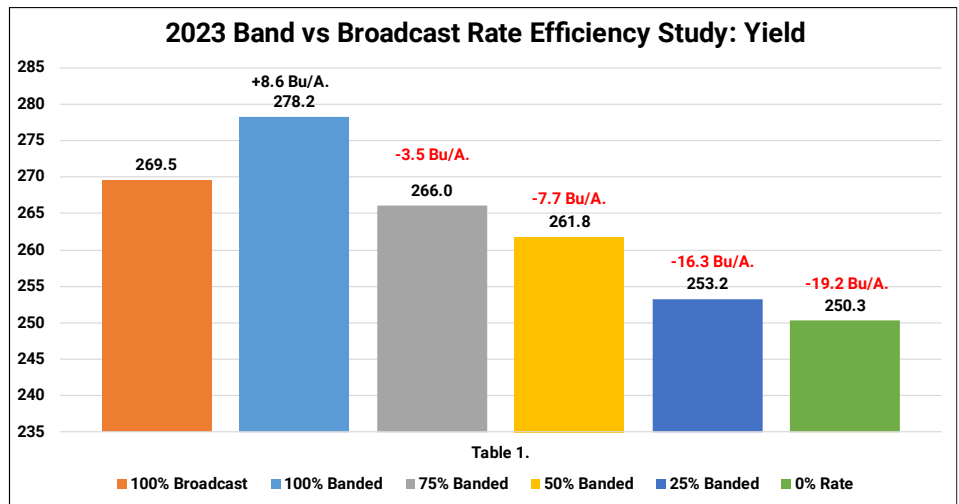


Broadcast vs Banding Rate Efficiency Study Continued

Results: Table 1. illustrates the yield of all rates in band and broadcast applications. Highest overall yield came from 100% banded application at 278.2 Bu/A., +8.6 Bu/A. better than 100% rates in a traditional broadcast application. As rates were lowered to 75% and 50% rates, yields fell by **-3.5** to **-7.7 Bu/A.** 25% bands resulted in significant losses of **-16.3 Bu/A.** Applying no fertilizer at all resulted in losses of **-19.2 Bu/A.**

Table 2. describes a telling story summarizing economics. 100% rate of fertilizer in bands resulted in net positive returns of **+\$36.59/A.**, however all other rate efficiencies tallied economic losses. 75% rates in bands resulted in losses of **-\$43.85/A.**, 50% banded rates at **-\$80.94/A.** and 25% fertilizer cost **-\$116.16/A.**

This study is part of a 10-yr study to help understand band vs broadcast and how reduced fertilizer and soil test levels could affect overall corn yield and economics. We are currently in year #3 of the study. As mentioned in our Multi-Yr Fertilizer Rate Study of this publication, it appears that one could question that reduced application rates may be drawing soil test levels down and could be hampering yield. Could early season drought be affecting the lower rates? We look forward to evaluating this over the next 7 years of this 10 year study.



Mosaic® Sulfur/Boron Dry Fertilizer Study

Objective: To evaluate yield and net return of Mosaic® fertilizer products MicroEssentials® SZ®, and Aspire® to offer sulfur and boron in addition to traditional dry phosphorous and potassium fertilizer.

MicroEssentials® SZ™ is a 12-40-0-10S-1Zn and combines nitrogen, phosphorus, sulfur, and zinc into one nutritionally balanced granule, creating a single source for balanced crop nutrition. The unique chemistry and precise nutrient ratio of MicroEssentials® features; uniform nutrient distribution, increased nutrient uptake, and season long sulfur availability.

Formulated using Nutriform® technology, Aspire® is a 0-0-58 that provides two forms of boron (Sodium Borate 50% and Calcium Borate 50%) with potassium into a single granule for uniform nutrient distribution, season-long boron availability and flexible spring or fall application.

In this study, both Mosaic products are equivalently compared to traditional applications of 230#/A. of 18-46-0 DAP and 130#/A. of 0-0-60 potash as a control.



<i>MicroEssentials</i> SZ				
12	40	0	10	1
N	P ₂ O ₅	K ₂ O	S	Zn

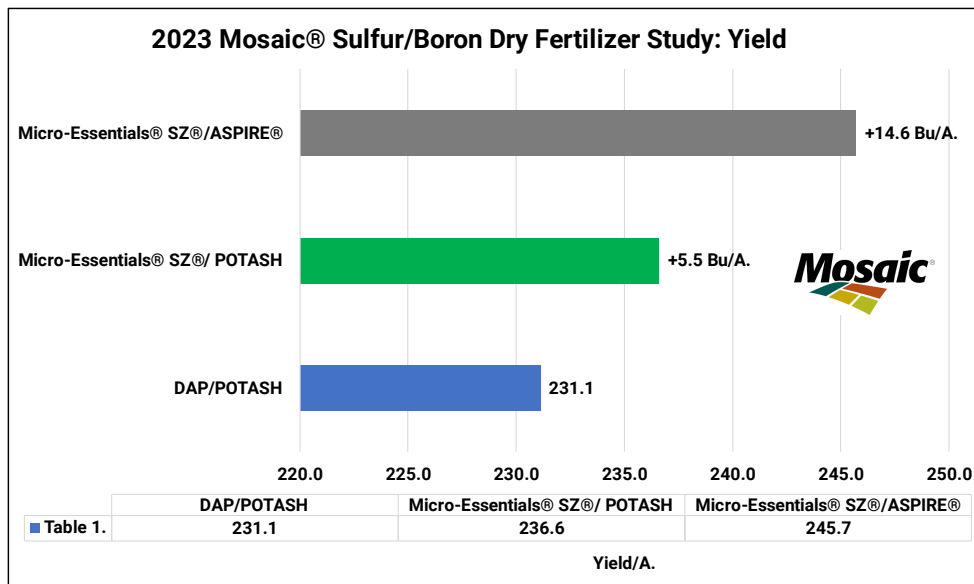
<i>Aspire</i>			
0	0	58	0.5
N	P ₂ O ₅	K ₂ O	B

Mosaic® Sulfur/Boron Dry Fertilizer Study

Boron (B) is a micronutrient critical to the growth and health of all crops. It is a component of plant cell walls and reproductive structures. Boron, a water-soluble micronutrient, is especially prone to leaching. Since boron is a neutrally charged ion, it floats in ecosystems until it finds a substance to which it can bond to. During periods of heavy rain, boron is flushed out of the soil quickly. Boron serves two primary roles; one is supporting plant cell division, and the second is during the silking stage of development, in which boron helps transfer water and nutrients from the roots up through the plant. B is required in small amounts, in fact a 200 Bu/A. crop only uptakes 0.2lbs of B.

Sulfur (S) is an essential nutrient for corn growth and is a critical nutrient to make required proteins. One bushel of corn typically requires 0.1 to 0.12lbs/Bu. S uptake occurs over the entire growing season, with relatively constant uptake from the 14-leaf stage to maturity. Unlike nitrogen, only 40% to 50% of S is taken up by flowering. S is also very mobile in most soils, like nitrate, because it has a double negative charge and is repelled by the negative charge of the soil, unlike nutrients like potassium, calcium, or magnesium


Results: Mosaic® Micro-Essentials® SZ® offered yield advantages of +5.5 Bu/A. over a traditional DAP program. These yield advantages equated to positive net returns of +\$13.54/A. after cost of product. ASPIRE® treatments offered yield advantages of +9.1 Bu/A. over the Micro-Essentials® SZ®/ POTASH program, and equated to a positive return of +\$35.72/A. Overall, the full Mosaic® program resulted in yield gains of +14.6 Bu/A. with net returns of +\$49.46/A. compared to a traditional DAP/POTASH program.



Planting Date: 4/26 Hybrid: DKC 66-17RIB Population: 36K Row Width: 30" Rotation: CAB Corn Price: \$5.31 Mosaic SZ/ASPIRE: \$170.52/A.
 Mosaic SZ/POTASH: \$157.91/A. DAP/POTASH: \$142.25/A.

Liquid vs Dry Fertilizer Fall Strip-Till Study

Objective: To evaluate yield and economic impact of dry and liquid fertilizer program in fall strip-till bands. This 1st year study compares a traditional dry 18-46-0 and 0-0-60 fertilizer program versus a replacement liquid fertilizer program. Treatments were as follows:

<u>#1: 100% Dry Fertilizer Program:</u>		
150# 18-46-0 + 150# 0-0-60		
<u>#2: 50% Dry Fertilizer Program:</u>		
75# 18-46-0 + 75# 0-0-60		
<u>#3: Control: No Fertilizer Applied</u>		
<u>#4: Liquid Fertilizer Program: 50% Nutrient Equivalent to Dry Program</u>		
12.5 Gal/A.	Nachurs® Throwback® 9-27-4-4S	
20 Gal/A.	Nachurs® K-flex® 0-0-19-6S	
<u>#5: Liquid Fertilizer Program: 100% Nutrient Equivalent to Dry Program</u>		
25 Gal/A.	Nachurs® Throwback® 9-27-4-4S	
40 Gal/A.	Nachurs® K-flex® 0-0-19-6S	



Liquid vs Dry Fertilizer Fall Strip-Till Study

All liquid treatments were applied in the Fall made with Black Eagle Ag Solution's strip-till unit.



This bar was fitted with Pump Stack® (Figure 1.), a liquid fertilizer hydraulic pump. It was paired with EMHD®, and EM Flowsense™ (Figure 2.) to ensure a top-notch fertilizer application, as well as row control across the bar. EMHD® controls liquid application rates using an electromagnetic flow meter. This opens your options for a wider range of liquid products. EM Flowsense™ allows you to measure the rate of fertilizer you are applying on each row of the bar, to make you aware of any row-to-row variability that is occurring. With a Pump Stack® system, paired with EMHD®, and EM Flowsense™ you can be confident in your application rate across every row.



Figure 1. Pump Stack®



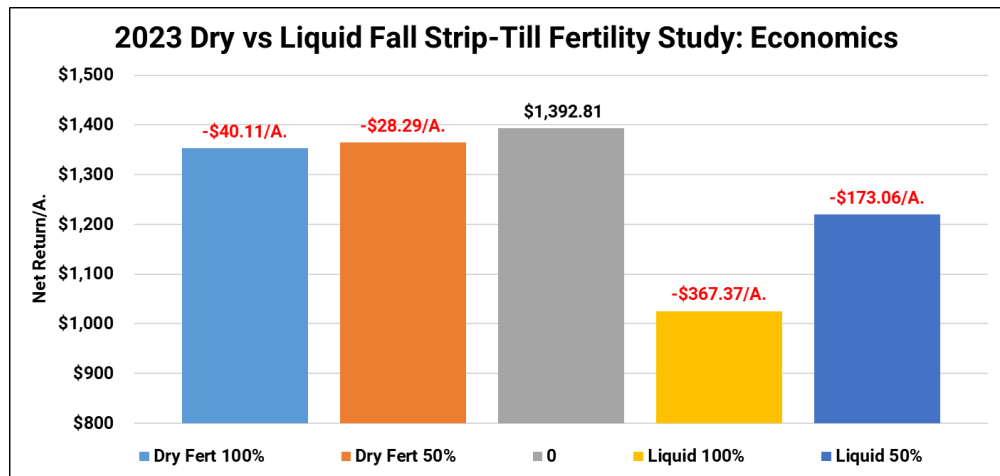
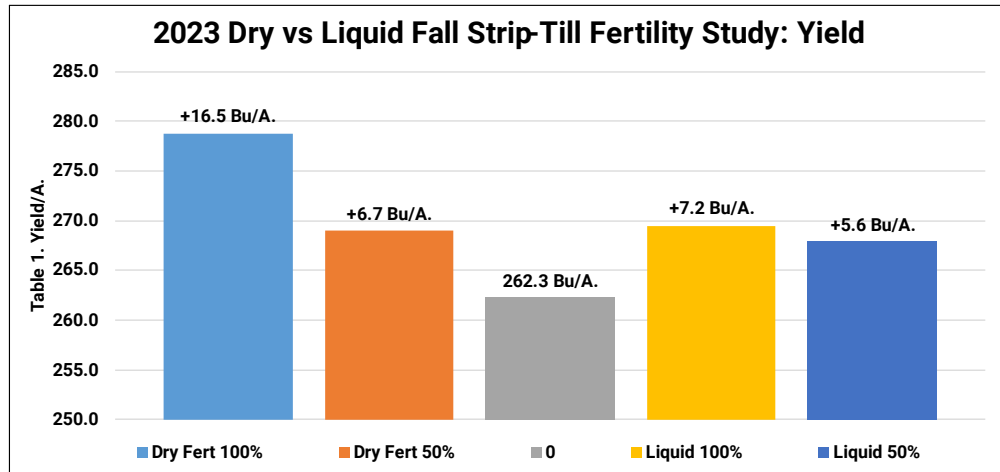
Figure 2. EMHD® EM Flowsense™

Liquid vs Dry Fertilizer Fall Strip-Till Study

Results: Table 1. illustrates both 100% rate dry fertilizer applications offered the highest yield response at +16.5 Bu/A. over the untreated control. Cutting rates back to 50% of dry resulted in a -41% reduction in yield down to +6.7 Bu/A. gains. Both liquid rates posted yield gains of +5.6 to +7.2 Bu/A. over the untreated control.

Table 2. reveals the overall economics of the fertilizer. All fertilizer treatments posted net economic losses, with liquid rates the highest at **-\$173.06/A.** to **-\$367.37/A.**

Dry fertilizer rates both posted negative losses of **-\$28.29/A.** to **-\$40.11/A.** Due to the high cost of fertilizer, break-even yield needed was +24.1 Bu/A., much higher than realized in the field.



Overall, the Black Eagle strip-till unit performed well in regard to tillage. However, due to high cost of fertilizer the all applications failed to achieve profitability of the dry program.

Calcium Products™ 98G™ Pell Lime Corn Study:



Objective: This trial evaluates the yield response and economics of pelletized limestone (98G™) applied fall broadcast.

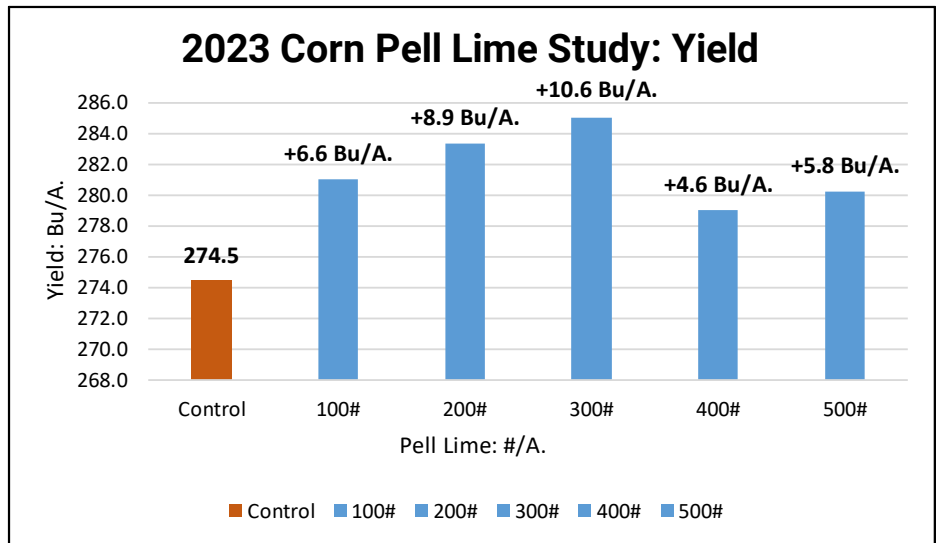
Soil pH is the foundation of nutrient availability and critical to maximizing crop yield. The availability of all nutrients is impacted by soil pH levels, especially phosphorus (P).

When soil pH is below 6.0, it can reduce your yield by as much as 30%. Calcium Products' 98G™ pelletized limestone is the most effective and consistent product to correct and maintain soil pH.

<p>Maintain Soil pH 98G can be applied in flat-rate or variable-rate applications. It can be mixed with other dry fertilizers reducing the number of trips across the field and spread spring or fall. This flexibility means you can address soil pH when and how it works for you with the same equipment used to spread other dry fertilizers. Once soil pH is restored, use 98G to maintain pH levels with more frequent, lower rate applications.</p>	<p>Change Soil pH Quickly 98G corrects soil pH faster and more completely than aglime. It is the most reactive liming material because it's made from 98% pure calcitic limestone and ground to an ultra-fine powder before it is pelletized. 98G pellets are engineered and manufactured to a specific size and hardness so that the pellets handle well and spread uniformly yet break down in the field to change soil pH. 98G is fully reactive at about three to six months after application.</p>
---	--

Soil pH has traditionally been addressed about every four years with aglime. Rather than create a pH "rollercoaster" in the field with infrequent aglime applications, 98G® can be used as part of a pH maintenance program with annual or biannual applications. 98G® is a more reactive liming material than aglime, keeping soil pH at a level to maximize yield potential (typically 6.0) year after year.

Results: Broadcast treatments of 98G™ Pell Lime were applied in rates of 100#-500#/A. in Fall of 2022. All rates proved yield advantages of +4.6Bu/A to +10.6Bu/A. 200#/A. rate proved economic optimum at +\$17.26/A. net returns.



Planting Date: April 28th Hybrid: GH14B32 Population: 36K Row Width: 30" Rotation: CAB Corn Price: \$5.31 Pell Lime: \$240/Ton + \$6/A Application

Calcium Products™ S04™ Corn Study

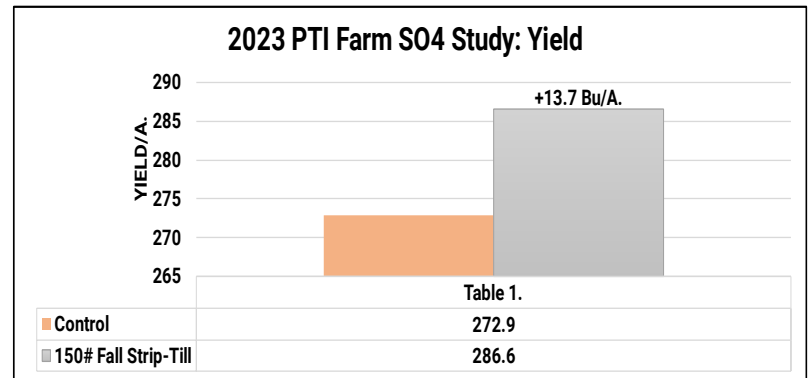
Objective: This trial evaluates the yield response and economics of pelletized calcium sulfate (S04) applied fall broadcast and as banded spring strip-till. Sulfur is an essential component of plant growth with key processes relying on chlorophyll formation and protein production. Sulfur is considered the fourth major nutrient behind N, P, and K.



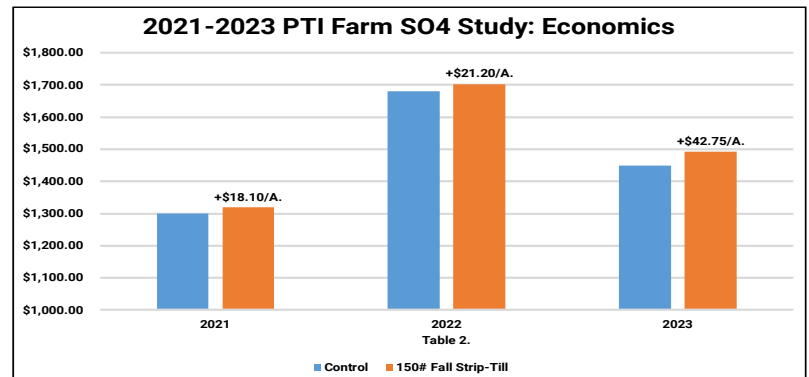
S04™ from Calcium Products is a 21% Calcium (non-pH neutralizing) and 17% Sulfur dry pelletized fertilizer, mined, and manufactured in NW Iowa. It is finely ground and pelletized to achieve a balance of solubility and pellet strength.

<p>Releases Sulfur to Match Plant Needs S04 supplies a balanced initial sulfur release, and a steady supply throughout the growing season. AMS releases sulfur to quickly, and elemental sulfur releases sulfur to slowly, neither meeting the crop's complete needs.</p>	<p>Spreads Easily S04 consistent pellet size allows it to be blended and applied with other dry fertilizers, which means it doesn't require a separate application. It can be applied pre-plant in the spring, in-season via top dress or post-harvest in the fall.</p>	<p>Will Not Acidify Soil S04 is pH neutral, meaning it will not acidify the soil like other sulfur sources. Proper soil pH maximizes a plant's utilization of nutrients promoting good plant health and optimizing yield.</p>
--	--	--

Historically, much of the sulfur need was satisfied with atmospheric deposition as result of coal burning industries. However, amendments to the Clean Air Act in 1990 targeted sulfur emissions, resulting in less than ½ of the amount of sulfur today compared to 30 years ago.



Results: Banded strip-till applications of S04 resulted in yield gains of +13.7 Bu/A. over the control. Banded S04 achieved net returns of +\$42.75/A.



Multi-year data from 2021, 2022 and 2023 has proven +9.4 Bu/A. yield gains with positive return on investment of +\$27.35/A. on all strip-till banded applications of S04.

Planter Applied Micro-Nutrient Study

Objective: To evaluate yield and net return of dry micronutrient fertilizer products at planting. The goal of this study is to use low-rate micronutrient fertilizer products applied at-plant, using a Gandy® Dry fertilizer box on the back of a planter row unit (Figure 1). All fertilizer is banded, and surface applied with some incorporation of planter closing system on 30” planted rows. In this study we tested The Andersons® MicroMark® DG Humic B product, compared to a liquid Nachurs imPulse starter fertilizer program – at different rates.



Figure 1. Gandy® Fertilizer Box on PTI Plot Planter



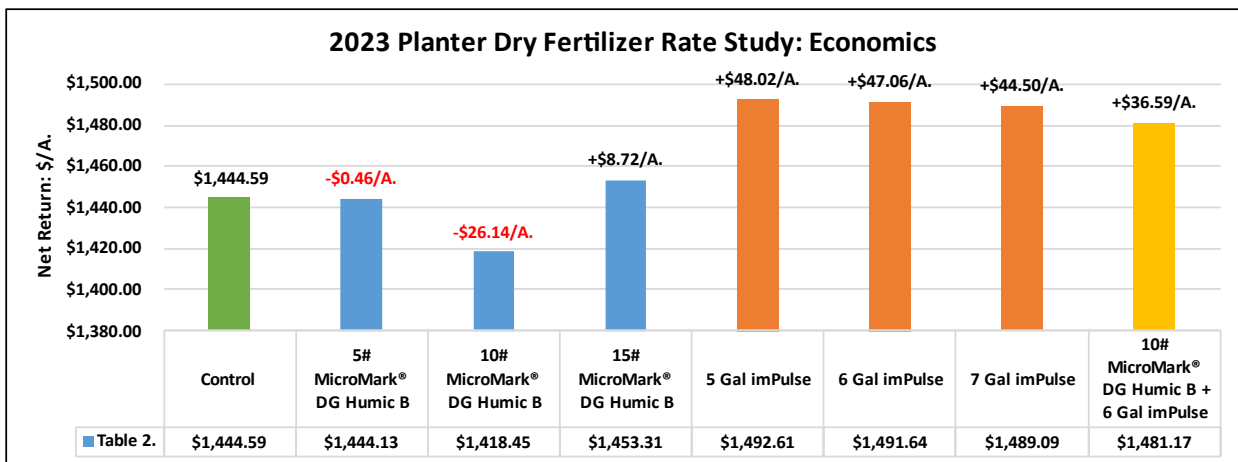
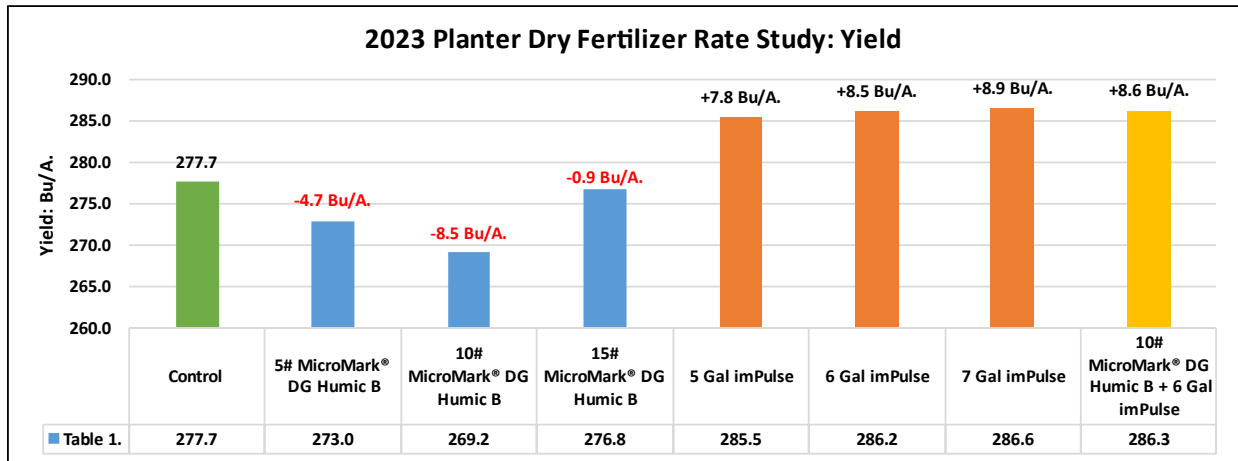
MicroMark® DG Humic B: A granular micronutrient product featuring The Andersons® Dispersing Granule (DG) Technology. With DG Technology, particles are efficiently broken down through hydrolysis, increasing the efficacy of nutrients. MicroMark® DG Humic B contains a unique blend of 36% Calcium sulfate dihydrate 9% Calcium, 11% Sulfur, 4% Manganese, 5% Zinc, and 1% Boron. MicroMark® DG Humic B also includes humic acid which is a natural chelator of micronutrients and has been shown to improve soil health.

Results: Table 1 illustrates The Andersons® MicroMark® DG Humic B product realized yield losses at all three rates, **-4.7 Bu/A**, **-8.5 Bu/A.**, and **-0.9 Bu/A.** respectively compared to the control. We had an abnormally dry early season this year at the PTI Farm, which is what we attribute to some of this yield loss. In April, May, and June we were down -2.52”, -3.69”, and -4.31” of rainfall off the average.

Planter Applied Micro-Nutrient Study Continued

The liquid starter fertilizer rates of 5, 6, and 7Gal/A of Nachurs imPulse resulted in yield gains of +7.8 Bu/A to +8.9 Bu/A. We then did a combination treatment of 10# MicroMark® DG Humic B along with 6-Gal imPulse, and that treatment resulted in a yield gain of +8.6 Bu/A. over the control.

Table 2 illustrates the economics for this study. The 5#, and 10#/A. rates of MicroMark® DG Humic B failed to break even after the price of the product. The 15#/A. rate realized net gains of +\$8.72/A. All liquid starter fertilizer treatments in this study proved positive economic gains of +\$44.50/A. to +\$48.02/A. The combination treatment incurred net economic gains of +\$36.59/A.



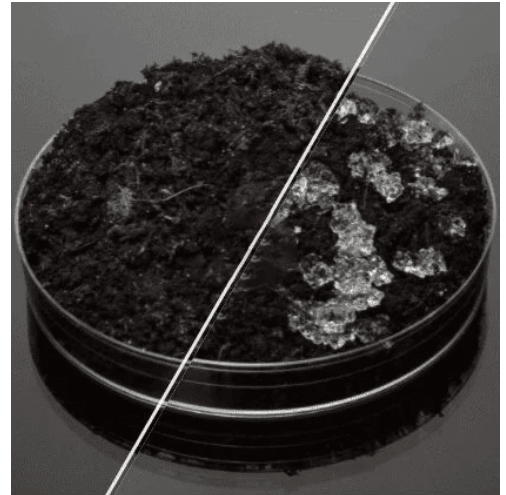
Planting Date: May 5th Hybrid: Wyffels 7208RIB SS Population: 36K Row Width: 30" Rotation: CAB, Strip-Till Corn Price: \$5.31

MicroMark® DG Humic B: \$1.10/# imPulse: \$4.68/Gal Fertilizer Reallocation: \$30

Planter Applied AQUASORB Study

Objective: To evaluate yield and net return of AQUASORB at planting. The goal of this study is to apply AQUASORB using a Gandy® Dry fertilizer box on the back of a planter row unit (Figure 1). All product is banded, and surface applied with some incorporation of planter closing system on 30" planted rows.

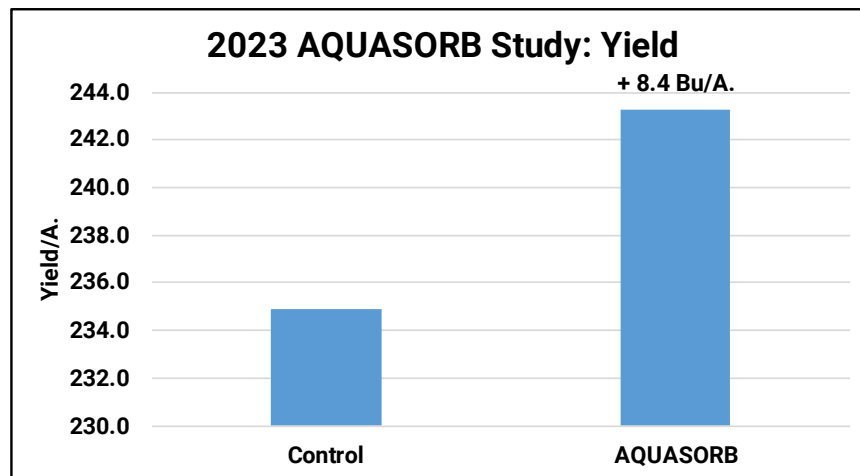
AQUASORB is a water retainer that is incorporated into the soil and retains large amounts of water and nutrients. The absorbed water and nutrients are easily released allowing the plant access when needed. This helps farmers improve irrigation efficiency, increase water holding capacity and protect against erosion and crusting.



Results: Soil applied treatments of AQUASORB resulted in yield gains of +8.49 Bu/A. Pricing unavailable for economic calculation.



Figure 1. Gandy® Fertilizer Box on Planter



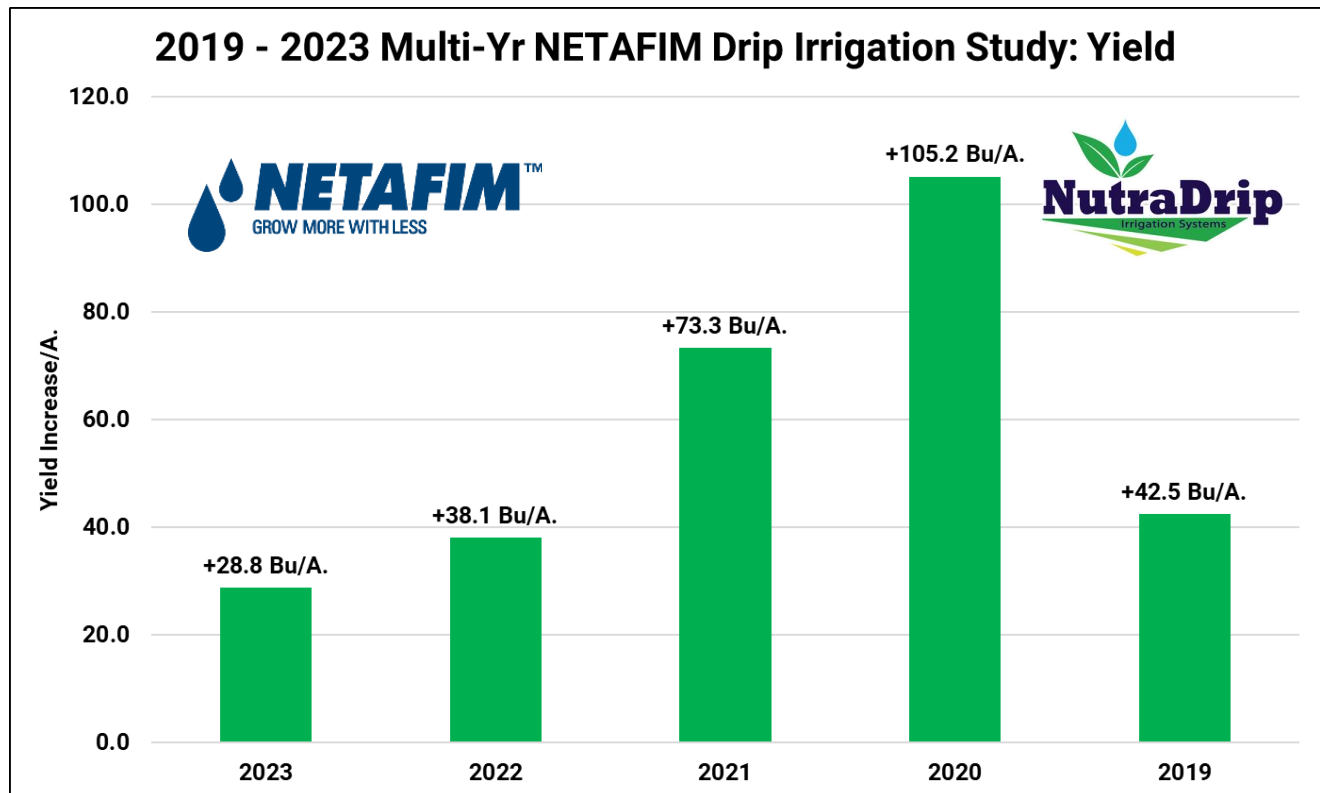
Planting Date: May 15th Hybrids: GH 03R40 Population: 36K Row Width: 30" Rotation: CAC Corn Price: \$5.31

High Management Corn NETAFIM™ Irrigation Study

Objective: This study evaluates NETAFIM™ drip tape irrigation designed by NutraDrip Irrigation Systems, and its' ability to feed corn with water and nutrients for high yield potential. This method of irrigating a crop uses NETAFIM® drip tape with small pressure regulated emitters evenly spaced at 24" apart. Water is accessed from a water recycling management program installed at the PTI Farm.

Results: In 2023, NETAFIM™ drip tape irrigation resulted in increased average corn yields of 28.8 Bu/A., over the non-irrigated control. 6" of rain was applied through drip irrigation throughout the growing season from June - September. 2023 marks the lowest annual yield response over the 5-yr of drip irrigation at the PTI Farm.

Multi-Year data over 2019-2023 has proven to increase corn yield by an average of +57.6 Bu/A., while increasing additional gross income by an average of +\$259.70/A.



NETAFIM™ Sub-Surface vs Surface-Irrigation Study

Objective: This study evaluates NETAFIM™ drip tape irrigation and its ability to feed corn with water and nutrients for high yield potential in a surface and sub-surface installation.

This method of irrigating a crop uses NETAFIM™ drip tape with small pressure regulated emitters evenly spaced at 24" apart. Water is resource from a water recycling management program installed at the PTI Farm.

Surface irrigation is placed on top of the soil surface on 60" spacing down the middle of the 30" row (Figure 1).

Sub-surface irrigation is buried 14" in depth on 40" centers (Figure 2). Sub-surface irrigation was installed in the fall of 2021.

Figure 1. NETAFIM™ Surface Irrigation



Figure 2. NETAFIM Sub-Surface Irrigation

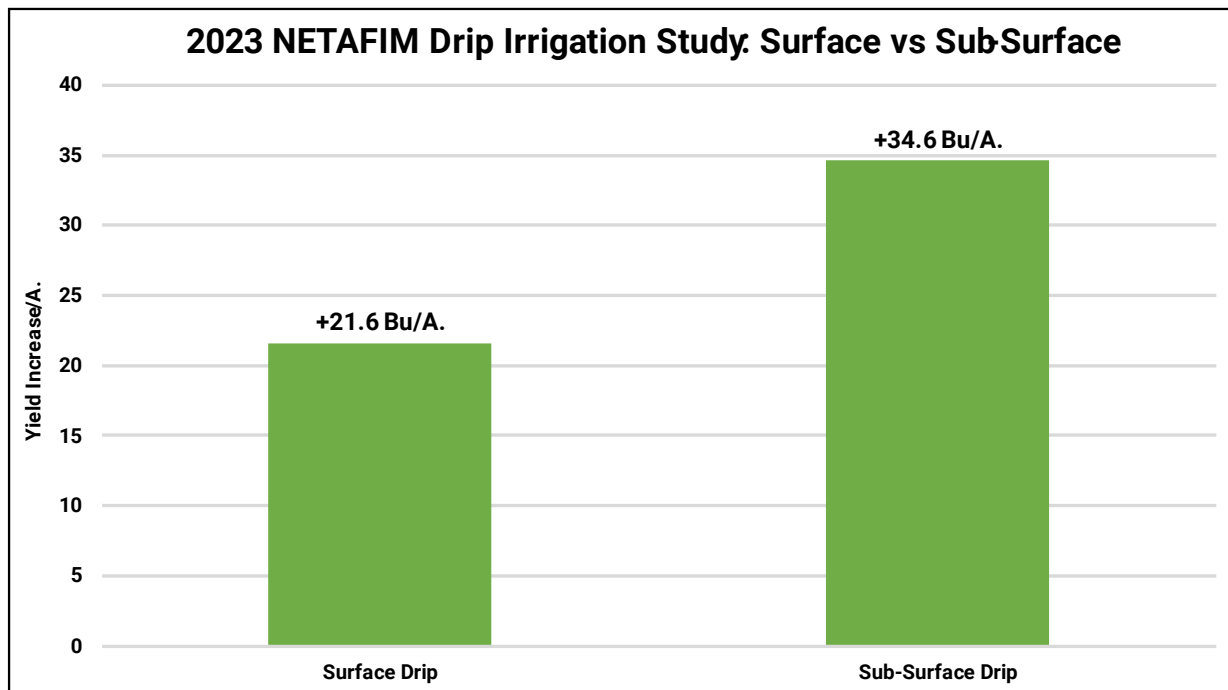


NETAFIM™ Sub-Surface vs Surface-Irrigation Study

Results: NETAFIM™ sub-surface drip tape irrigation resulted in increased average corn yields of +13.0 Bu/A., over surface applied drip tape. Sub-surface irrigation tape was installed in the fall of 2021 and just like drainage tile, we had a suspicion that it may take some time for sub-surface drip irrigation to settle into place correctly, repair soil density of installation, and get proper water permeability throughout the soil profile quickly. These positive yield gains of 13.0 Bu/A. are encouraging to see, as 2022 (the first year of this study) tallied +6.6 Bu/A. gains.

Surface drip irrigation has its advantages and disadvantages. It can be an effective, faster way to get water to a crop, however it can suffer moisture losses being exposed to sunlight, temperature, and wind on the soil surface. Keeping the soil surface moist can also lead to a higher threat of disease. Labor is also a concern, as the tape needs to be manually laid and picked up annually.

6.0" of rain was applied through drip irrigation throughout the growing season from June - September.



Tile Drainage and Sub-Irrigation Study

Objective: To evaluate the performance of using field tile as a form of irrigation. Normally, field tile is used to only drain saturated soils (Figure 1.) However, in this study we installed 15' and 30' 3" plastic field tile to compare its ability to not only drain water, but to also back-feed irrigation water back through the field tile to offer irrigation to a growing crop.

Figure 2. shows the layout of our pattern tiled field installed in the early spring of 2021. Both 15' and 30' pattern tile widths were used to understand the difference in the soil's capillary action or uptake of water. This study is one of many at the PTI Farm designed as long-term 10+ year studies to study consistency and longevity of the system.

Figure 1. Tile Installation



Figure 2. 15' and 30' Pattern Tile Installation



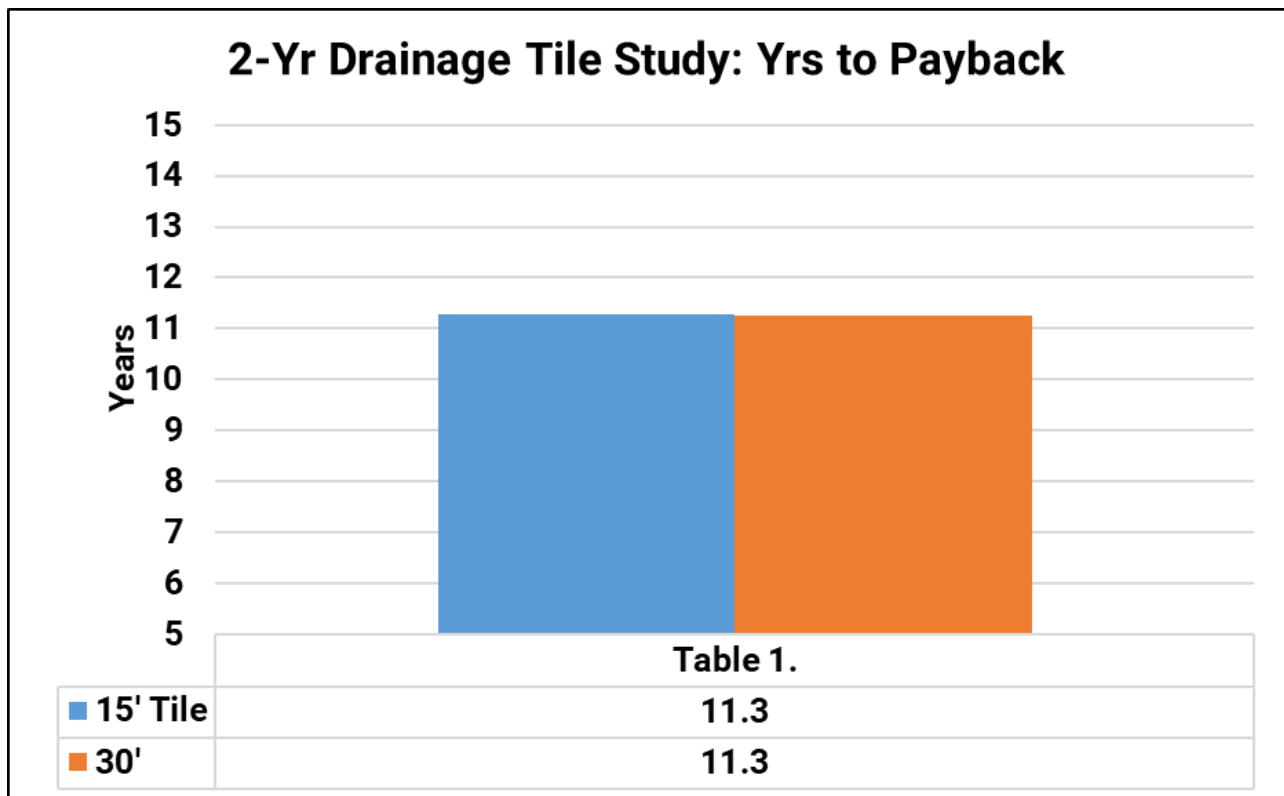
Tile Drainage and Sub-Irrigation Study

Results: The first objective of this study was to evaluate the differences between tile spacing. In 2023, 15' pattern tile offered yield advantages of +17.4 Bu/A, which equates to additional gross farm revenue of +\$92.39/A.

30' pattern tile offered yield advantages of +12.4 Bu/A. and gross revenue of +\$65.84/A. These numbers would indicate that it fell behind 15' pattern tile by only **-5.0 Bu/A.** with corresponding gross revenue loss of only **-\$26.55/A.** We believe this small discrepancy is due to the lack of heavy rainfall events throughout the growing season. In fact, 6" of irrigation water was needed throughout the summer months to offset the lack of rainfall.

Based on data from 2022-2023, Table 1. illustrates that both 15' and 30' tile pattern systems would pay for themselves after 11.3 crop seasons (\$850/A. 30' Tile, \$1160/A. 15' Tile). This is interesting, as the overall tile response of +12.4 to +17.4 Bu/A. are somewhat low. In wet years this would be anticipated to be much higher. This is the significance of a 10-yr study's ability to show differences in multiple years and within those years, different environments.

In two dry years in 2022 and 2023, tile is still a good investment with a 11.3 year payback.



Tile Drainage and Sub-Irrigation Study

Secondly, the other objective of this study, is using the drainage tile as option to sub-irrigate. Figure 3. is a photo of a gate system that gives the ability to control the water table. Gates can be added or removed to allow water to “back-feed” or “fill up” the tile, which in turn draws water up into the soil profile. Water is sourced and pumped out of the PTI Farm’s water recycling reservoir to back-feed the water through the tile system in the field.

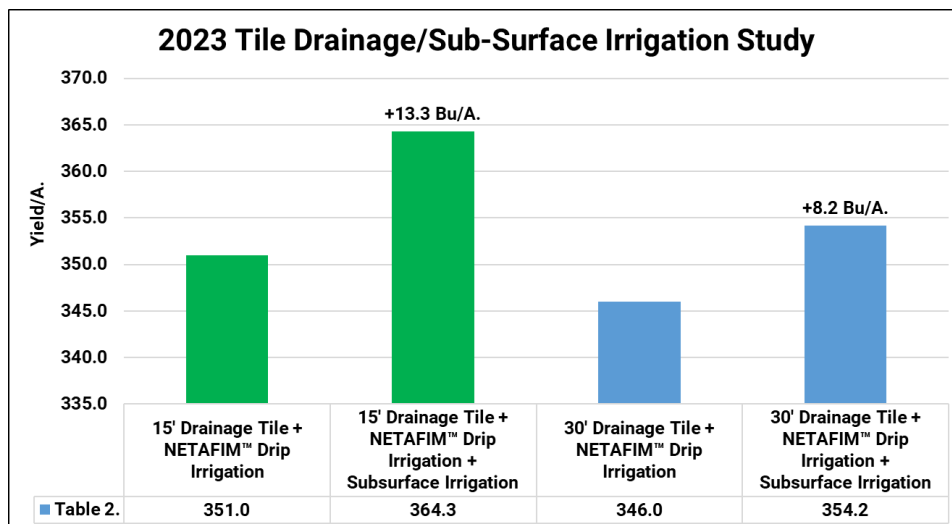
Table 2. illustrates back-feeding water gained +13.3 Bu/A. in 15’ tile pattern tile and only +8.2 Bu/A. in 30’ tile patterns.

Though seemingly small yield gains, what was an 11.3-yr payback period mentioned above from just drainage gains, multi-year back-feeding gains would contribute additionally and thus lower payback to 7.5 crop seasons in 15’ tile and 7.7 years in 30’ tile patterns.

Figure 3. Gate Structures to Control Water Table



It should be noted that NETAFIM™ drip tape was used as the primary irrigation source for all treatments and the back-feeding of water for secondary irrigation. We did this mainly because back-feeding of water in tile does not allow the use of fertigation. Applying nutrients such as N, P, or K could contaminate water supply, so tile is used for water irrigation only. The NETAFIM® drip tape is used for additional water as well as fertigation.



High Management Corn Strip Cropping Study

Objective: To achieve high yield corn in an intense management environment with proper field drainage, irrigation and sound practical and realistic agronomic practices. This trial utilizes the water recycling system at the PTI Farm to drain saturated soils when wet and then recycles that rainwater to irrigate and fertigate with in hot dry summer months. The field protocol for high yield consisted of the following:

1. Strip-Cropping:

- Alternating 10' blocks of corn and soybeans/cover crop
- Outside Rows: 40K Seed Rate Inside Rows: 38K

2. At-Plant Conceal® and FurrowJet® Nutrition

- 50 Gal 32% UAN (Conceal)
- 3 Gal/A. Nachurs® KFuse®(6-0-12-12) (Conceal)
- 8 Gal/A. Marco QuickGrow LTE (6-20-4-.25Zn-2.7S)(FJ)

3. Irrigation/Fertigation

- 6" Recycled rain fed by NETAFIM™ Drip Tape
- 5 Gal/A. Ammonium ThioSulfate(12-0-0-26S)
- 1 Gal/A. 10% Boron
- 5 Gal QLF Agronomy BOOST™ (4-0-3-2S)

4. UAV Foliar Feed/Protection Program

- V10: 1 Gal Nachurs® KFuel®(0-0-24)
- V10: SideDress 2 Gal/A. Nachurs® K-flex® Max (0-0-19-6S)
- V10: 1Qt Nachurs® FinishLine®(8-4-6+Micros)
- VT: 2# Marco Foliar Complete (8-12-40)
- R1: 4Gal/A. QLF Amino 15™ (15-0-1)
- V10, VT, R1, R3, R5 2 Gal/A. Water Conditioner



High Management Corn Strip Cropping Study

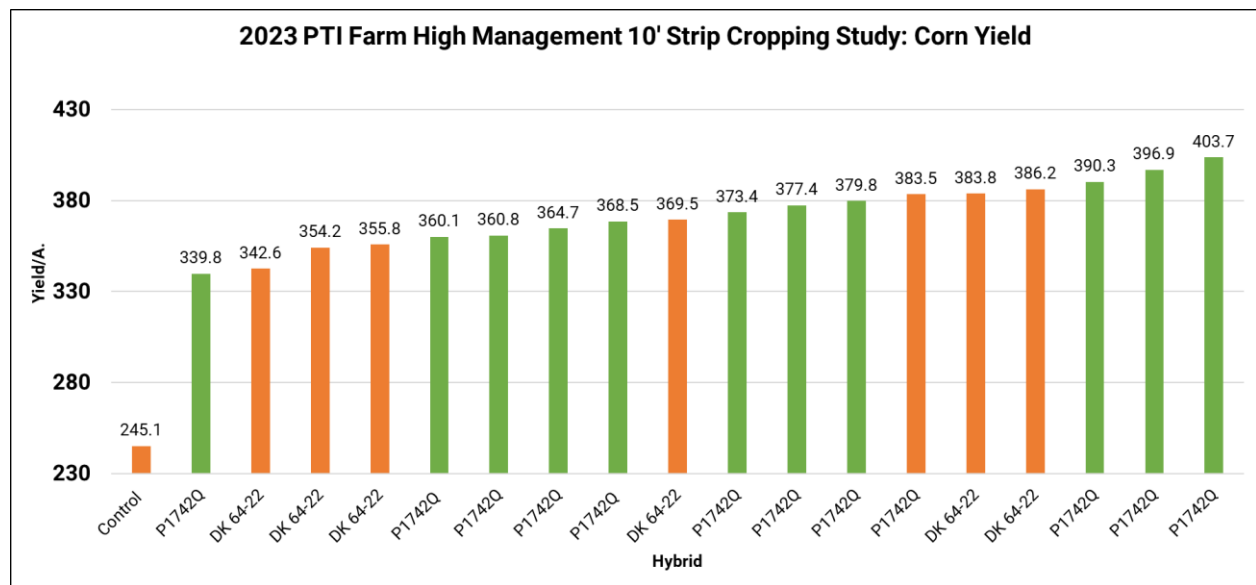
The control in the study is dryland, non-strip-crop, and status quo low management corn planted at 36K, fertilized with dry 200# 18-46-0 and 200# 0-0-60, and 180# total nitrogen. Table 1. illustrates yield results of all entries in the study. Pioneer® 1742Q and DeKalb® 64-22 were used as our high yielding corn hybrids. 245.1 Bu/A. is used at the control in the study, as it is an average of actual corn yield from the PTI Farm in a non-irrigated, non-high managed program.

Results: Yields ranged up to 63.9 Bu/A. between all treatments with Pioneer 1742Q averaging 379.4 Bu/A. and Dekalb 64-22 at 365.4 Bu/A. These yields were +120.3 to 134.3 Bu/A. above status quo average low-management program.

The table to the right, summarizes high yield levels at the PTI Farm since its inception back in 2018. 2020 began our first full year of our water management program, where recycling of rainwater from field tile first was initiated.

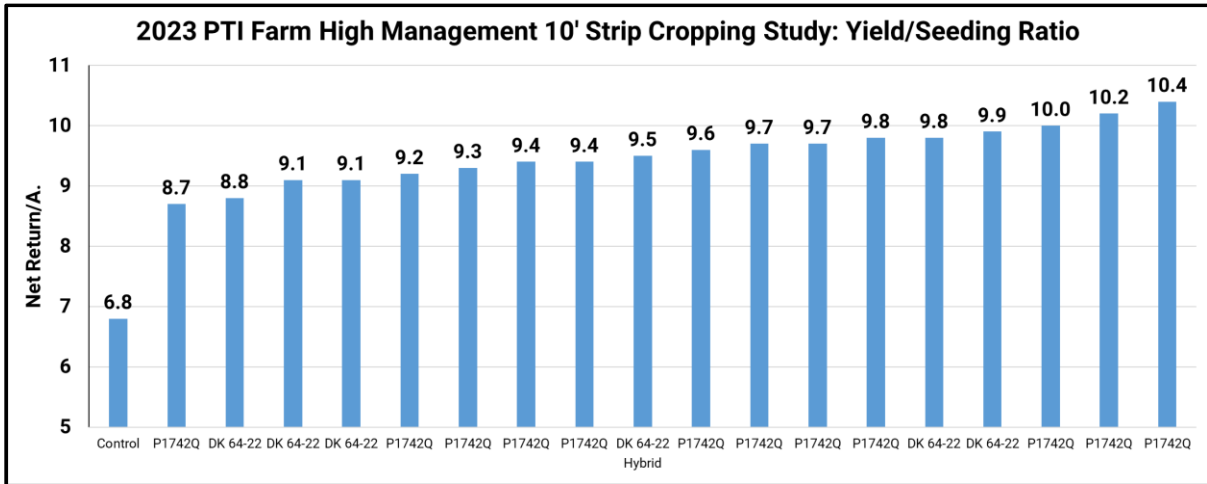
Year	Hybrid	Yield
2018	Pioneer® 1197	272.5 Bu/A.
2019	Dekalb® 53-56	285.0 Bu/A.
2020	Dekalb® 63-42	368.2 Bu/A.
2021	Golden Harvest® 15J91	357.9 Bu/A.
2022	Channel® 212-04	398.4 Bu/A.
2023	Pioneer® 1742Q	403.7 Bu/A.

Pioneer® 1742Q topped the charts this year with a yield of 403.7/A., while Dekalb® 64-22 reached its highest yield level at 386.2 Bu/A.



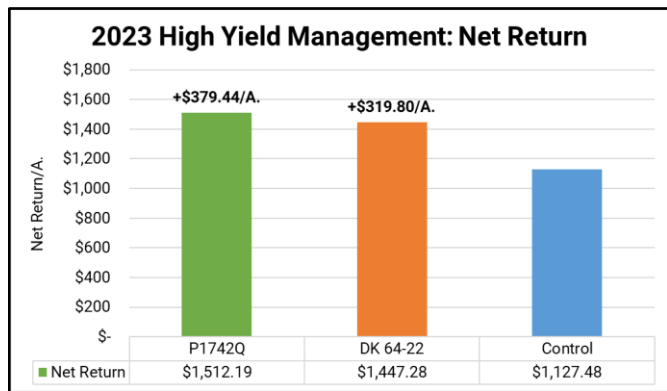
High Management Corn Strip Cropping Study

It is our goal at the PTI Farm for corn yield to be 7-10 times our seeding rate. The table below summarizes yield to seeding rate ratios. Our control yield of 245.1 Bu/A. is a result of average seeding rates of 36K, which gives a ratio of 6.8 Bu/1000 seeds planted (245.1/36). rows achieving slightly higher yields of +14.3 Bu/A. compared to south planted rows. High yield attempts in strip cropping, achieved ratios of 8.7 to 10.4 Bu/A.



One important aspect to consider to any trial, especially a high yield corn trial, is economics. High yield trials simply have more costs and these costs to be paid for. If yield cannot be increased enough to pay the bills, it's simply not sustainable. High yields are great, but we need bushels to pay for the additional products we are applying.

The graph to the right illustrates average net return for each corn hybrid, compared to the control. The high management program did in-fact achieve positive net returns, with averages at +\$319.80 to +\$379.44/A. These returns indicate this high management study is sustainable and not only are we increasing corn yield, but we are making more dollars/A. Now the question is; how do we accomplish this on more acres and how do we continue to increase corn yield and profitability?



High Management Corn Irresponsible Nitrogen Rate Study

Objective: To evaluate higher than normal nitrogen rates to prove that nitrogen is **NOT** the yield limiting factor in growing high yield corn.

Farmers often ask why we do not normally apply absurdly high rates of nitrogen as a component of our high management corn trials? It has been the PTI Farm team’s opinion that 299#’s of nitrogen should be the maximum rate in our high yield trials. This 299# rate serves two purposes. First, we can honestly say we are not applying 300# of nitrogen/A. This may sound paradoxical, but the PTI Farm team has not been proponents of irresponsibly high nitrogen rates. In fact, we often say that if it is going to take more than 300# of nitrogen to grow ultra high yield corn, it may not be environmentally or even economical to justify.

However, over the past six years farmers have asked how we can prove that nitrogen is not the yield limiting factor in our high yield corn studies, since we maximize nitrogen rate at 299#/A. To help answer this question, the PTI Farm team finally broke down and decided to take the advice of growers wanted to see higher nitrogen rates, to prove them wrong.

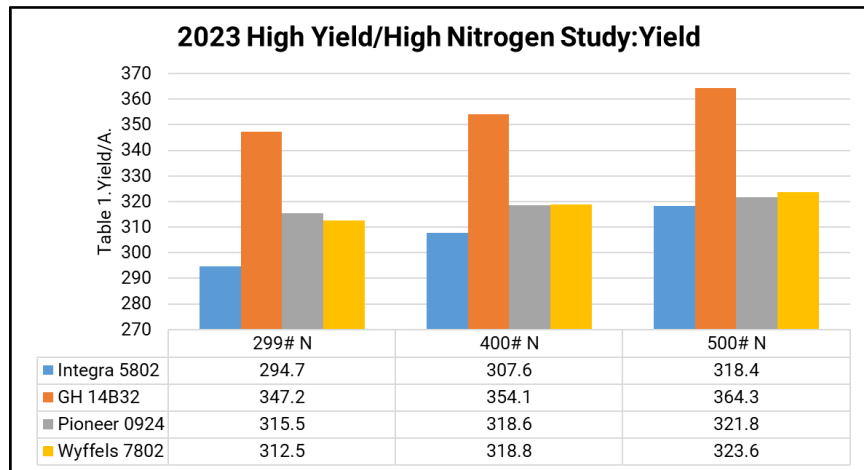
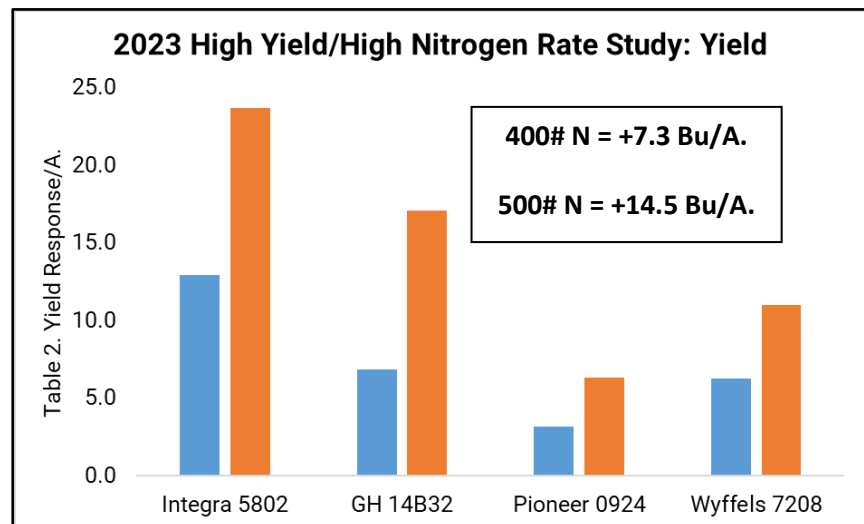


Table 1. illustrates the average yields of four corn hybrids with applied nitrogen rates of 299#, 400#, and 500#/A. Nitrogen was applied as 25# Weed-N-Feed, 25% planter applied, and 50% side-dress. All four hybrids realized yield gains from the higher rates of nitrogen over and above the standard PTI Farm rate of 299#/A.

Table 2. reveals all four hybrids did in-fact offer higher corn yield from higher N rates. 400# N rates averaged yield increase of +7.3 Bu/A. , while 500# N rates doubling that at +14.5 Bu/A.



2023 PTI Results

High Management Corn Irresponsible Nitrogen Rate Study

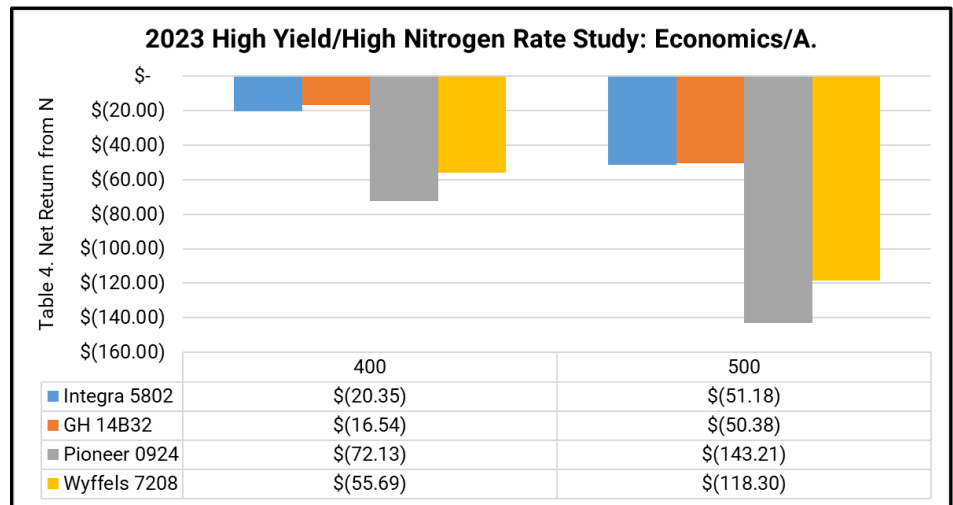
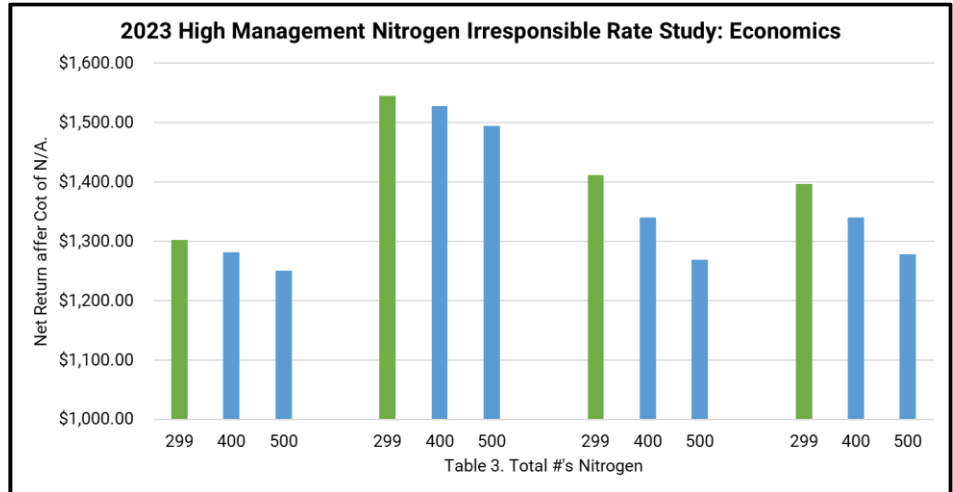
The help clarify the true story behind this study, Table 3. reveals all four hybrids obtained the highest economic net returns at the 299# nitrogen rate. As N rate was increased to 400-500# levels, even though corn yield did increase, it was not enough to justify the additional expense of nitrogen. Table 4. Illustrates individual net loss/A. of all four corn hybrids at 400-500# N rate. 400# N rates averaged **-\$41.18/A.** economic losses, while 500# rates at **-\$90.76/A.**

In summary, yes higher nitrogen rates of 400-500#/A. did increase overall corn yield, however by only +7.3 to +14.5 Bu/A. These corn yield responses may have contributed to slight yield increase, but did not offer positive return on investment after additional cost of nitrogen.

For each 100# nitrogen rate increase, corn yield would have needed additional corn yield of +16.6 Bu/A.

(NUE) Nitrogen use efficiency (N rate/corn yield) averaged 0.9 Bu/A. corn yield for each #of N applied at the 299# N rate.

400# N rates tallied a NUE score of 1.2 Bu/A. corn yield for # of N, while 500# scored 1.5.



In conclusion, high yield studies should not only evaluate yield potential, but they should also focus on return on investment. If net return is not achievable from increased crop inputs, farm sustainability is in jeopardy. Furthermore, the over-application of nitrogen was not only a loss on investment, it further complicates the issues of nitrogen losses such as leaching, denitrification, and volatilization.

AgroLiquid® High Management Corn Nutritional Study: Irrigated

Objective: To evaluate the yield and economic impact of a corn liquid starter fertilizer and foliar nutritional program from AgroLiquid in a high management irrigated environment. This trial consisted of the following:

Treatments and Placement:

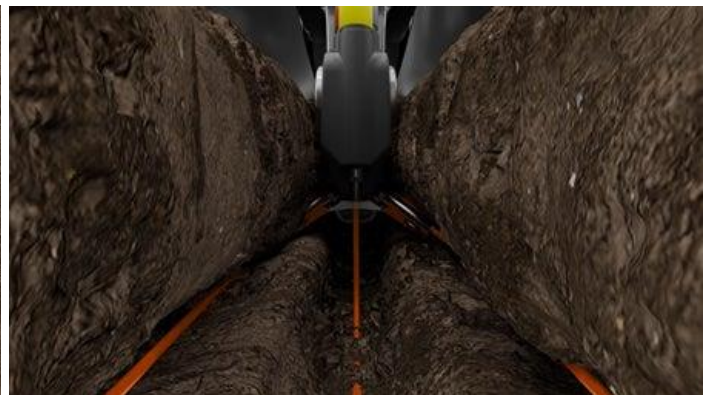
#1. Control:	200# DAP, 200# 0-0-60, Less R3 Fungicide, Less 40# N
#2 At-Plant Fertility:	
Conceal® Dual Band: (Figure 1.)	3 Gal/A. accesS™, 27 Gal/A. 32% UAN
FurrowJet® Center: (Figure 2.)	2 Gal/A. SpringUp®, 0.75 Gal/A. Micro500™ 0.25 Gal/A. LiberateCa™
FurrowJet® Wings: (Figure 2.)	2 Gal/A. ProGerm®, 2 Gal/A. Kalibrate™ 0.25 Gal/A. Boron, .25 Gal/A. LiberateCa™, 0.125 Gal/A. Manganese
#3 Post-Plant Applications:	
	V4: SideDress: 2 Gal/A. AccesS™, 2 Gal/A. Kalibrate™, 0.25 Gal/A. Boron
	VT: 1 Gal FertiRain™, 0.125 Gal/A. Boron, 0.125 Gal/A. Manganese, 1 Gal/A. Nresponse®



Figure 1. Conceal Placement



Figure 2. FurrowJet® Placement



AgroLiquid® Corn Nutritional Study: Irrigated Continued

All controls were planted at 36K seeding rates, while AgroLiquid treatments were evaluated at 36K, 38, and 40K seeding rates using both DeKalb 64-22 and Pioneer 1108Q. Control received -40# N (180# total N) and only one (VT) foliar fungicide pass, and 200# each of 18-46-0 and 0-0-60.

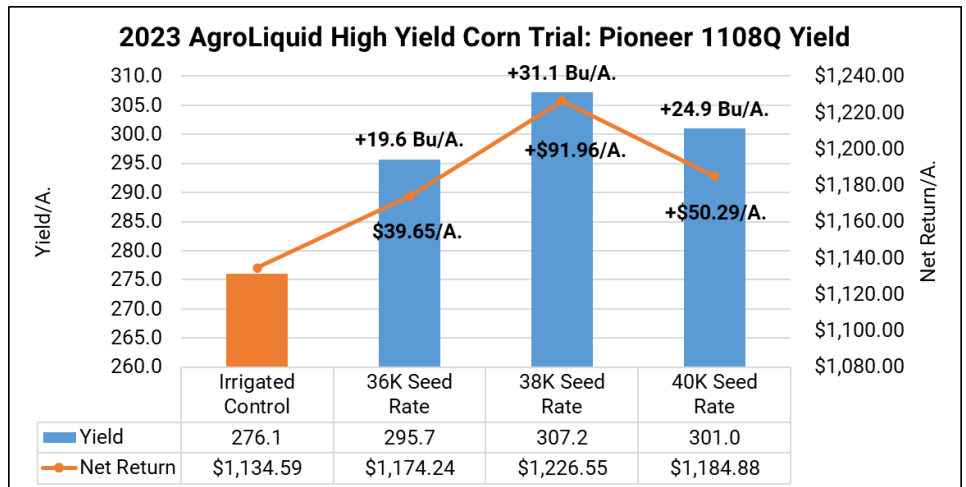
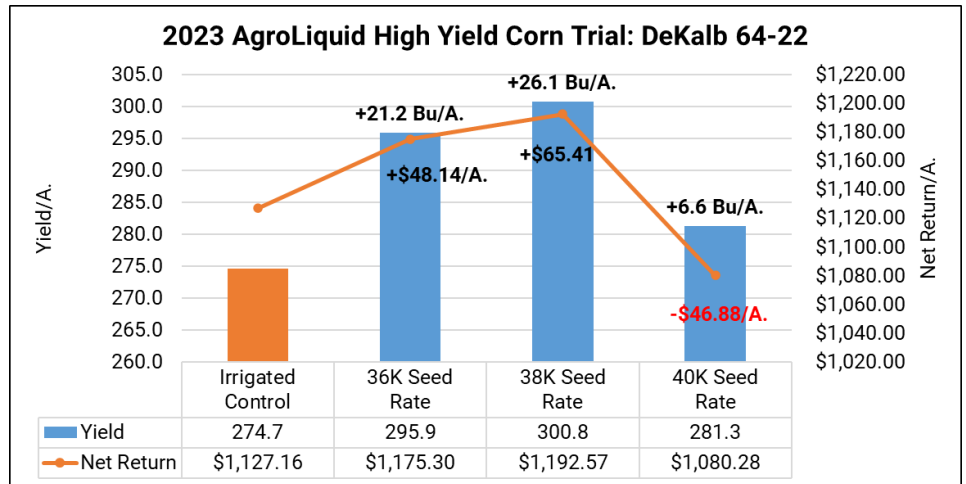
Irrigation on all treatments received 6" water throughout the growing season. High yield treatments received 13.7oz/A. of Miravis® Neo at VT and 13.7oz/A. of TrivaPro® at R3 growth stage, +40 additional N units and water conditioner.

Results: DeKalb 64-22 offered yield gains +21.2 to +26.1 Bu/A. increases at 36K and 38K seeding rates, however 40K rates diminished gains to only +6.6 Bu/A.

38K seeding rates proved economic optimum with a 300.8 Bu/A. yield, with an ROI at +\$65.41/A. 40K seeding rates resulted in losses of **-\$46.88/A.**

Pioneer 1108Q achieved economic optimum at 38K pops, with yield of 307.2 Bu/A. and an ROI at +\$91.96/A. The lower 36K pops resulted in **-11.5 Bu/A.** yield with **-\$52.31/A.** losses.

40K seeding rates proved too costly with yield deficit of **-6.2 Bu/A.** with losses of **-\$41.67/A.,** compared to economic optimum.



Planting Date: April 27th DKC 64-22, Pioneer 1108Q Population: 36K Row Width: 30" Rotation: CAB Corn Price: \$5.31
 Conceal® Program: \$21.09/A. FurrowJet® Program: \$101.87 SideDress Program: \$26.10/A. Foliar Program: \$23.77/A. DAP/Potash: \$870/\$770
 N Price: \$0.88/# (\$35.20/A.) Fungicide + Water Conditioner: \$30.40/A. Seed Cost: \$350/Bag

AgroLiquid® High Management Corn Nutritional Study: Dryland

Objective: To evaluate the yield and economic impact of a corn liquid starter fertilizer and foliar nutritional program from AgroLiquid in a high management dryland environment. This trial consisted of the following:

Treatments and Placement:


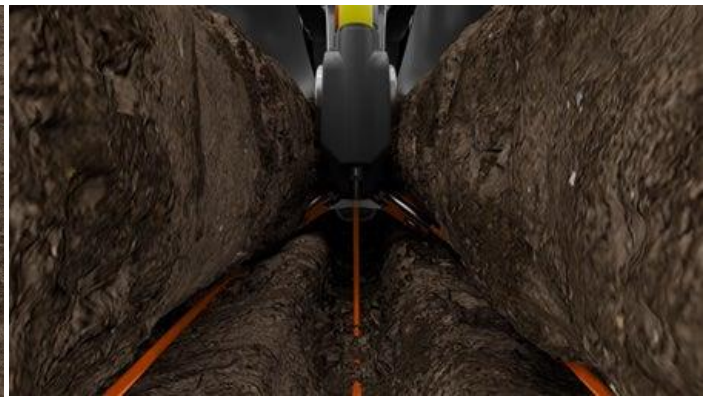
#1. Control:	200# DAP, 200# 0-0-60, Less R3 Fungicide, Less 40# N
#2 At-Plant Fertility:	
Conceal® Dual Band: (Figure 1.)	3 Gal/A. accesS™, 27 Gal/A. 32% UAN
FurrowJet® Center: (Figure 2.)	2 Gal/A. SpringUp®, 0.75 Gal/A. Micro500™
	0.25 Gal/A. LiberateCa™
FurrowJet® Wings: (Figure 2.)	2 Gal/A. ProGerm®, 2 Gal/A. Kalibrate™
	0.25 Gal/A. Boron, .25 Gal/A. LiberateCa™, 0.125 Gal/A. Manganese
#3 Post-Plant Application:	
	V4: SideDress: 2 Gal/A. AccesS™, 2 Gal/A. Kalibrate™, 0.25 Gal/A. Boron
	VT: 1 Gal FertiRain™, 0.125 Gal/A. Boron, 0.125 Gal/A. Manganese, 1 Gal/A. Nresponse®

Figure 1. Conceal Placement



Figure 2. FurrowJet® Placement



AgroLiquid® Corn Nutritional Study: Dryland Continued

All controls were planted at 36K seeding rates, while AgroLiquid treatments were evaluated at 36K, 38, and 40K seeding rates using both DeKalb 64-22 and Pioneer 1108Q. Control received -40# N (180# total N) and only one (VT) foliar fungicide pass, and 200# each of 18-46-0 and 0-0-60.

High yield treatments received 13.7oz/A. of Miravis® Neo at VT and 13.7oz/A. of TrivaPro® at R3 growth stage, +40 additional N units and water conditioner.

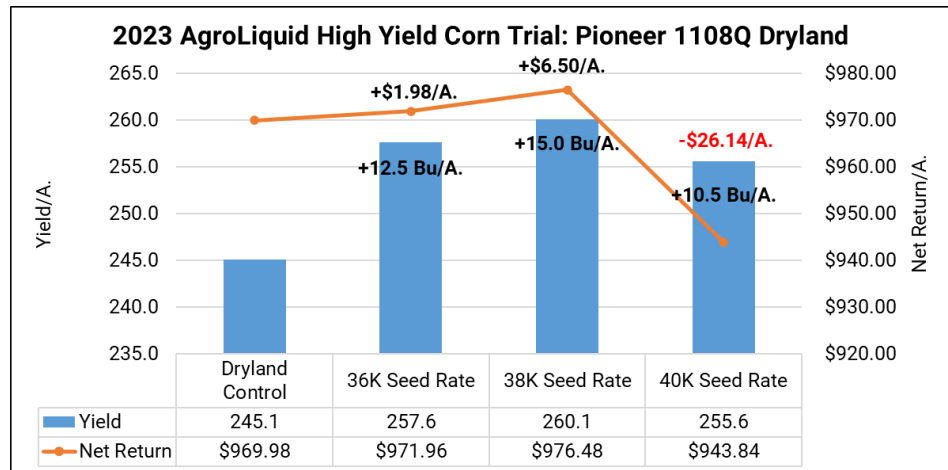
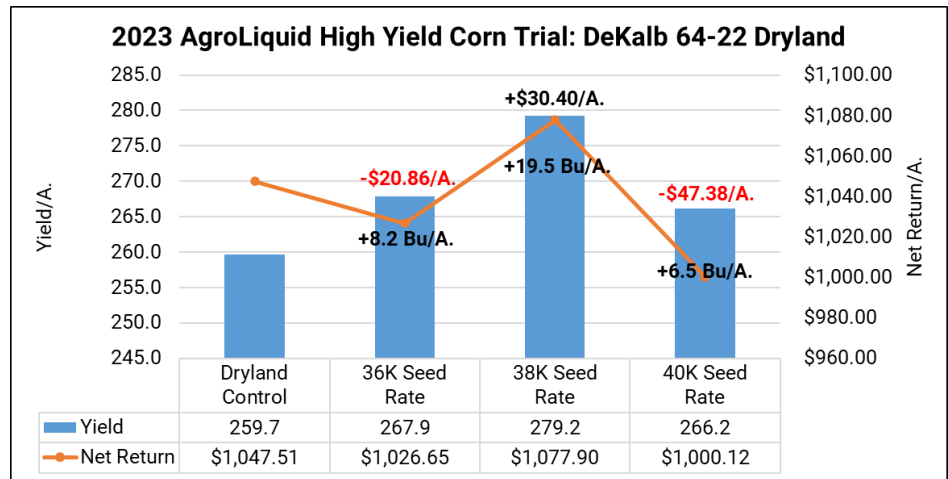
Results: DeKalb 64-22 achieved economic optimum at 38K seeding rates with +19.5 Bu/A. yield gain along with return of +\$30.40/A.

36K and 40K diminished yield gains by -11.3 to -13.0 Bu/A., and resulted in losses of -\$20.86/A. to -\$47.38/A. respectively.

Pioneer 1108Q offered economic optimum at 38K seeding rates with +15.0 Bu/A. yield gains and positive returns of +\$6.50/A.

Higher 40K seeding rates proved costly and tallied yield deficit of -4.5 Bu/A. with losses of -\$32.64/A. compared to optimum.

Dryland average yields were -30.2 Bu/A. compared to irrigated environments.



Planting Date: April 27th DKC 64-22RIB, Pioneer 1108Q@ Population: 36K Row Width: 30" Rotation: CAB Corn Price: \$5.31
 Conceal® Program: \$21.09/A. FurrowJet® Program: \$101.87 (C:\$51.66) (W: \$50.21) SideDress Program: \$26.10/A. Foliar Program: \$23.77/A.
 DAP/Potash: \$870/\$770 (\$174) N Price: \$0.88/# (\$35.20/A.) Fungicide + Water Conditioner: \$30.40/A. Seed Cost: \$350/Bag

Marco Fertilizer High Management Corn Study: Irrigated

Objective: To evaluate the yield and economic impact of a corn liquid starter fertilizer and foliar nutritional program from Marco Fertilizer in a high management irrigated environment. This trial consisted of the following:

Treatments and Placement:


#1. Control:	200# DAP, 200# 0-0-60, Less R3 Fungicide, Less 40# N
#2 At-Plant Fertility: FurrowJet® 3-Way: (Figure 1.)	3 Gal/A. QuickGrow Complete 3 Gal/A. Water
#3 Foliar Applications:	<div data-bbox="191 871 522 1066" style="float: left; margin-right: 20px;">  </div> V4: 1 oz/A. Poseidon 1 pt/A. Energizer 1# Foliar Complete 0.5pt/A. Iron Plus V10: 1 oz/A. Poseidon 1pt/A. Energizer 2# Foliar Complete VT: 1pt/A. Energizer 1# Foliar Complete

Figure 1. FurrowJet® Placement



Marco Fertilizer High Yield Study: Irrigated Continued

All controls were planted at 36K seeding rates, while Marco treatments were evaluated at 36K, 38, and 40K seeding rates using both DeKalb 62-69 and Wyffels 7945. Control received -40# N, only one (VT) foliar fungicide pass, and 200# each of 18-46-0 and 0-0-60.

Irrigation on all treatments received 6" water throughout the growing season. High yield treatments received 13.7oz/A. of Miravis® Neo at VT and 13.7oz/A. of TrivaPro® at R3 growth stage, +40 additional N units and water conditioner.

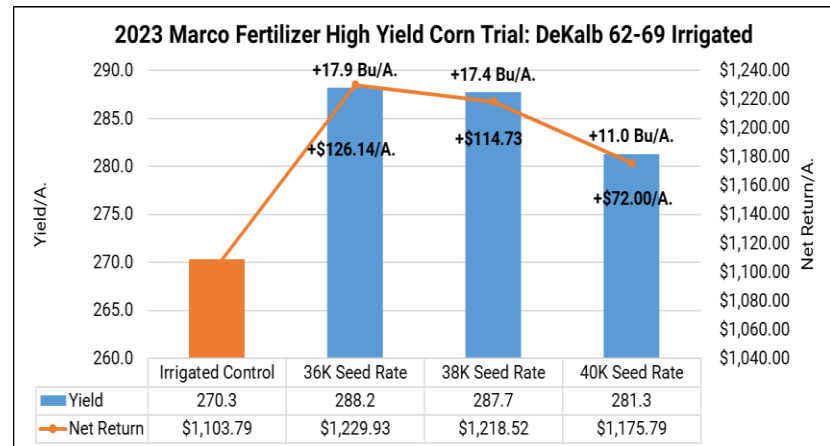
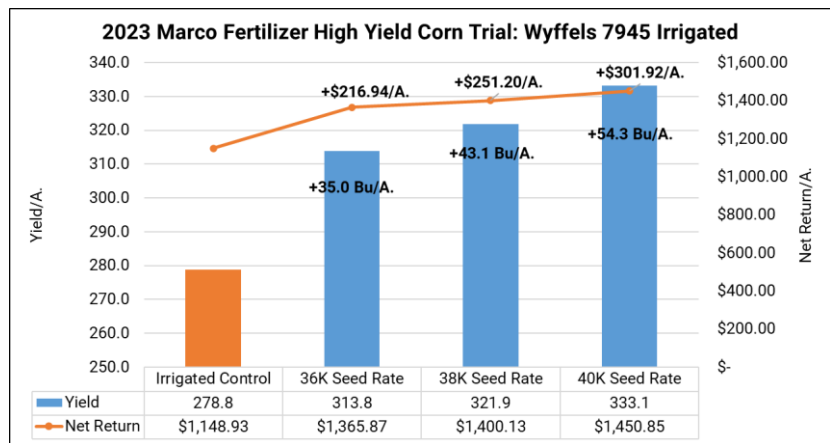
Results: Wyffels 7945 offered an impressive high corn yield of 333.1 Bu/A. at the highest seeding rate of 40K. As seeding rate was decreased to 38K or 36K, yield fell by **-11.2 Bu/A.** to **-19.3 Bu/A.** However, all seeding rates offered exceptional yield advantage over the control with yield gain ranging from +35.0 to +54.3 Bu/A.

These stout yield gains led to some of the highest economic returns the PTI Farm has received from past high yield trials. Economic returns averaged +\$216.94/A. to +\$301.92/A.

DeKalb 62-69 tallied its high yield of 288.2 Bu/A. at the lowest seeding rate of 36K. This high yield posted net returns of +\$191.74/A.

38K seeding rates were **-0.5 Bu/A.** lower with corresponding net losses of **-\$11.41/A.**

40K seeding rates still offered +11.0 Bu/A. overall yield gains, but **-6.9 Bu/A.** lower with losses of **-\$54.14/A.** compared to the optimum seeding rate of 36K.



Planting Date: April 27th Wyffels 7945RIB, DeKalb 62-69RIB Population: 36K Row Width: 30" Rotation: CAB Corn Price: \$5.31
 FurrowJet® Program: \$29.25 Foliar Program: \$48.06/A. DAP/Potash: \$870/\$770 (\$174/A.) N Price: \$0.88/# (\$35.20/A.)
 Fungicide+Water Conditioner: \$30.40/A. Seed Cost:\$350/Bag

Marco Fertilizer High Management Corn Study: Dryland

Objective: To evaluate the yield and economic impact of a corn liquid starter fertilizer and foliar nutritional program from Marco Fertilizer in a high management non-irrigated environment. This trial consisted of the following:

Treatments and Placement:


#1. Control:	200# DAP, 200# 0-0-60, Less R3 Fungicide, Less 40# N
#2 At-Plant Fertility: FurrowJet® 3-Way: (Figure 1.)	3 Gal/A. QuickGrow Complete 3 Gal/A. Water
#3 Foliar Applications:	<div data-bbox="191 871 522 1066" style="float: left; margin-right: 20px;">  </div> V4: 1 oz/A. Poseidon 1 pt/A. Energizer 1# Foliar Complete 0.5pt/A. Iron Plus V10: 1 oz/A. Poseidon 1pt/A. Energizer 2# Foliar Complete VT: 1pt/A. Energizer 1# Foliar Complete

Figure 1. FurrowJet® Placement



Marco Fertilizer High Yield Study: Dryland Continued

All controls were planted at 36K seeding rates, while Marco treatments were evaluated at 36K, 38, and 40K seeding rates using both DeKalb 64-22 and Pioneer 1108Q. Control received -40# N (180# total N) and only one (VT) foliar fungicide pass, and 200# each of 18-46-0 and 0-0-60.

High yield treatments received 13.7oz/A. of Miravis® Neo at VT and 13.7oz/A. of TrivaPro® at R3 growth stage, +40 additional N units and water conditioner.

Results: Wyffels 7945 performed incredibly with a high corn yield of 297.7 Bu/A. at the 38K seeding rate. All seeding rates were just exceptional, with yield gains of +30.5, +35.3, and +29.2 Bu/A. over the low management control.

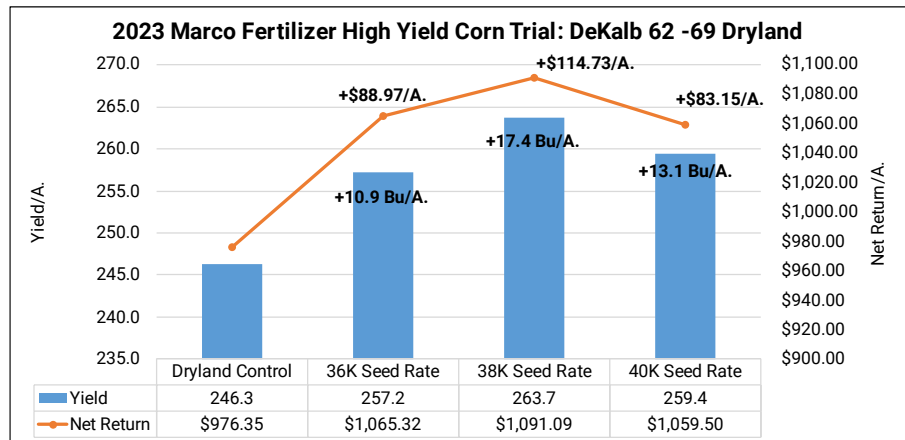
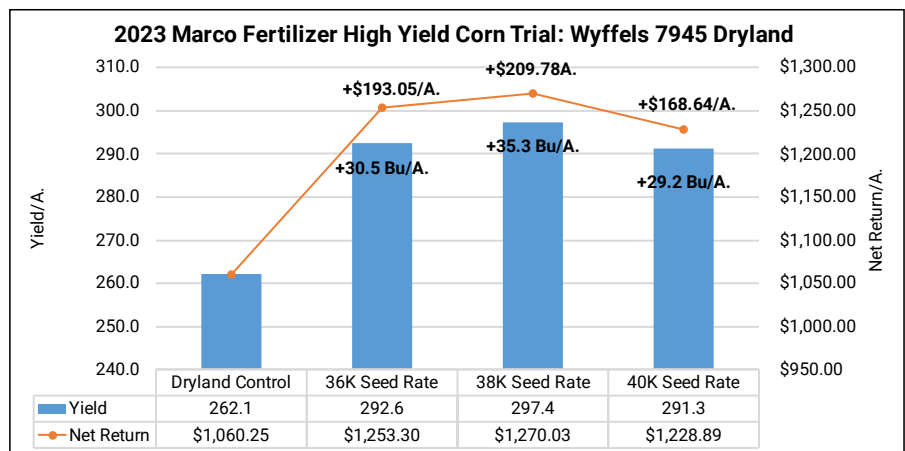
Economic returns tallied impressive gains of +\$168.64/A. to +\$209.78/A., with 38K pops achieving economic optimum seed rate.

DeKalb 62-69 tallied its agronomic and economic optimum at 38K seeding rates with a yield of 263.7 Bu/A. and returns of +\$114.73/A.

36K seeding rates were **-6.5 Bu/A.** lower with net losses of **-\$25.76/A.**

40K seeding rates still offered +13.1 Bu/A. overall yield gains, but **-4.3 Bu/A.** lower with losses of **-\$31.58/A.** compared to the optimum seeding rate.

Dryland yield decreased **-25.6 Bu/A.** in Wyffels in 7945 and **-25.2** in DeKalb 62-69.



Stoller® USA Fertilizer High Management Corn Study: Irrigated

Objective: To evaluate the yield and economic impact of a corn liquid starter fertilizer and foliar nutritional program from StollerUSA in a high management irrigated environment. This trial consisted of the following:

Treatments and Placement:


#1. Control:	200# DAP, 200# 0-0-60, Less R3 Fungicide, Less 40# N
#2 At-Plant Fertility:	
Conceal® Dual Band (Figure 1.)	1Qt/A. Harvest Plus™
FurrowJet® Center: (Figure 2.)	4oz/A. Fortified Stimulate Yield Enhancer® Plus 8oz/A. BioForge® Advanced
FurrowJet® Wings: (Figure 2.)	1Qt/A. Harvest Plus™, 1Qt/A. Charge 12%™
#3 Foliar Applications:	
	V4: 6oz Fortified Stimulate®, 8oz BioForge® Advanced, 1Qt/A. Harvest Plus™
	V6: 2.5#/A. Harvest More® UreaMate, 8oz/A. Xcyte™
	V8: 1Qt/A. Sugar Mover® Premier, 1Pt/A. Energy Power®
	V10: 8oz/A Xcyte™, 2.5# Harvest More® Urea Mate
	V12: 8oz/A Xcyte™, 2.5# Harvest More® Urea Mate
	VT: 1Qt/A. Sugar Mover® Premier, 2.5# Harvest More® Urea Mate®
	R2: 8oz/A. Xcyte™, 1Pt/A. Energy Power®
R4: 1Qt/A. Sugar Mover® Premier	

Figure 1. Conceal Placement



Figure 2. FurrowJet® Placement



Stoller® USA Fertilizer Corn Nutritional Study: Irrigated Con't

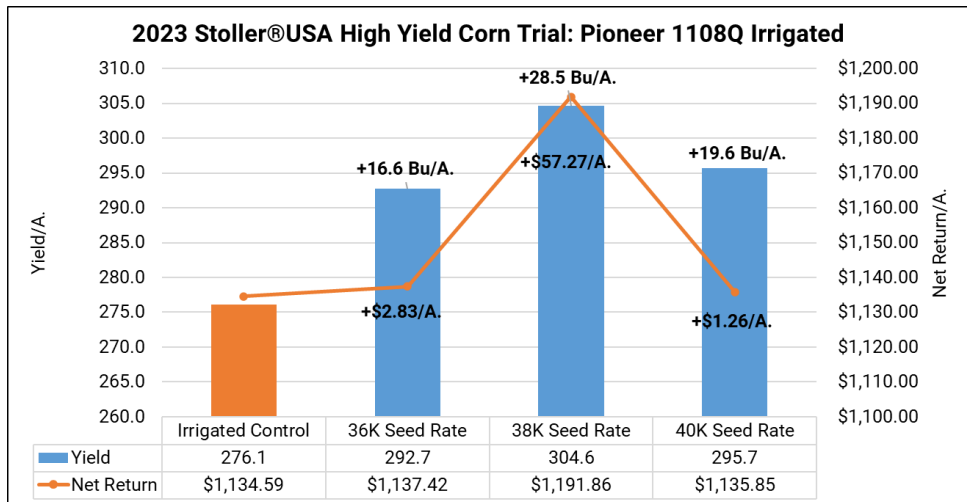
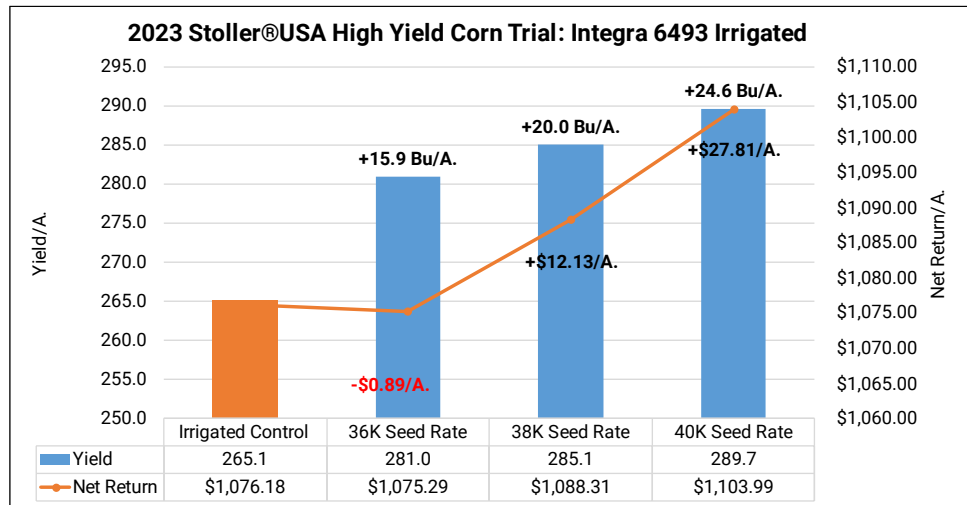
All controls were planted at 36K seeding rates, while Stoller treatments were evaluated at 36K, 38, and 40K seeding rates using both Pioneer 1108 and Integra 6493VT2P. Control received - 40# N (180# total N) and only one (VT) foliar fungicide pass, and 200# each of 18-46-0 and 0-0-60.

Irrigation on all treatments received 6" water throughout the growing season. High yield treatments received 13.7oz/A. of Miravis® Neo at VT and 13.7oz/A. of TrivaPro® at R3 growth stage, +40 additional N units and water conditioner.

Results: Integra 6493VT2Pro achieved both agronomic and economic optimum seeding at 40K, with yields of 289.7 Bu/A., +24.6 Bu/A. over control, and net returns of +\$27.31/A. Both yield and return increased as seeding rates climbed.

Pioneer 1108Q posted agronomic and economic optimum seeding rate at 38K with yield of 304.6 Bu/A., +28.5 Bu/A. over control, and net returns of +\$57.27/A.

Excellent overall yield response, however cost of program dampened net returns.



Planting Date: April 27th Hybrids: Pioneer 108Q, Integra6349VT2P Population: 36K Row Width: 30" Rotation: CAB Corn Price: \$5.31
 Conceal® Program: \$4.59/A. FurrowJet® Program: \$19.34/A. Post Program: \$169.79/A. DAP/Potash: \$870/\$770 N Price: \$0.88/# (\$35.20/A.)
 Fungicide+Water Conditioner: \$30.40/A. Seed Cost:\$350/Bag

Stoller® USA Fertilizer High Management Corn Study: Dryland

Objective: To evaluate the yield and economic impact of a corn liquid starter fertilizer and foliar nutritional program from StollerUSA in a high management dryland environment. This trial consisted of the following:

Treatments and Placement:


#1. Control:	200# DAP, 200# 0-0-60, Less R3 Fungicide, Less 40# N
#2 At-Plant Fertility:	
Conceal® Dual Band (Figure 1.)	1Qt/A. Harvest Plus™
FurrowJet® Center: (Figure 2.)	4oz/A. Fortified Stimulate Yield Enhancer® Plus 8oz/A. BioForge® Advanced
FurrowJet® Wings: (Figure 2.)	1Qt/A. Harvest Plus™, 1Qt/A. Charge 12%™
#3 Foliar Applications:	
	V4: 6oz Fortified Stimulate®, 8oz BioForge® Advanced, 1Qt/A. Harvest Plus™
	V6: 2.5#/A. Harvest More® UreaMate, 8oz/A. Xcyte™
	V8: 1Qt/A. Sugar Mover® Premier, 1Pt/A. Energy Power®
	V10: 8oz/A Xcyte™, 2.5# Harvest More® Urea Mate
	V12: 8oz/A Xcyte™, 2.5# Harvest More® Urea Mate
	VT: 1Qt/A. Sugar Mover® Premier, 2.5# Harvest More® Urea Mate®
	R2: 8oz/A. Xcyte™, 1Pt/A. Energy Power®
R4: 1Qt/A. Sugar Mover® Premier	

Figure 1. Conceal Placement



Figure 2. FurrowJet® Placement



Stoller® USA Fertilizer Corn Nutritional Study: Dryland Con't

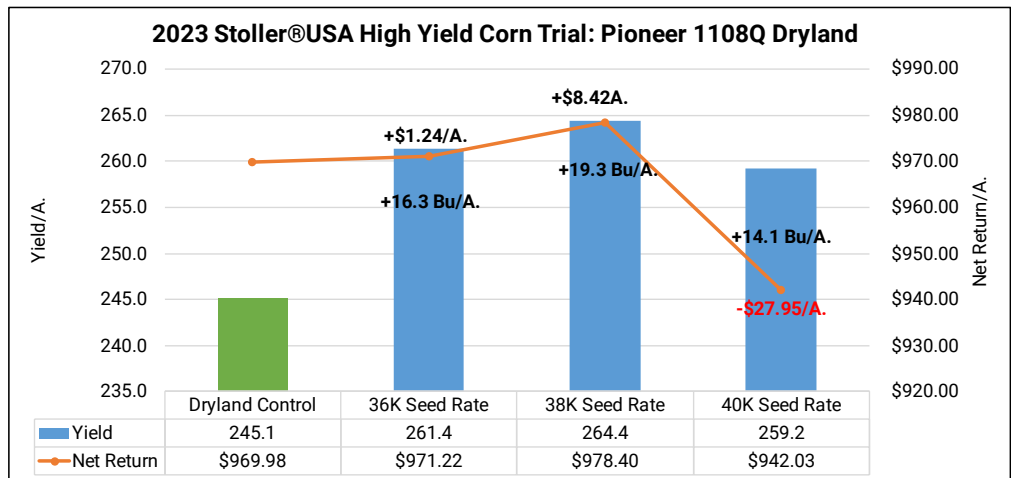
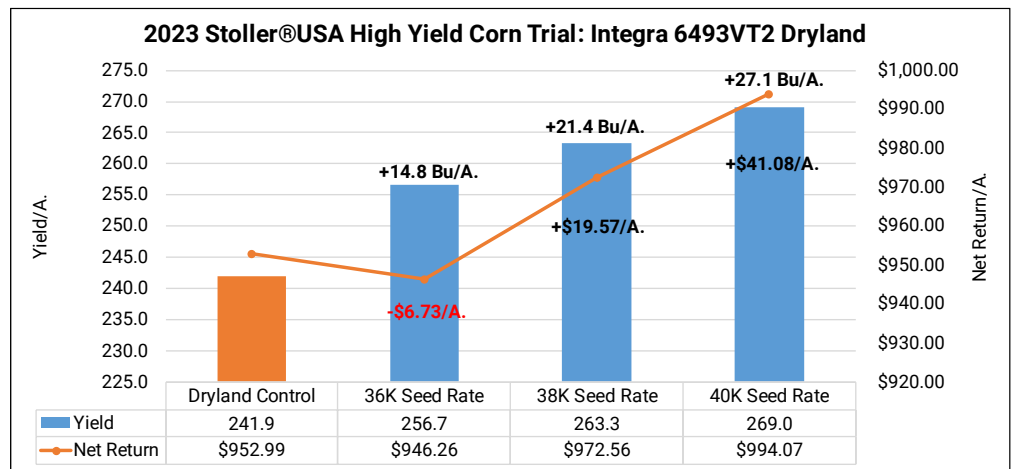
All controls were planted at 36K seeding rates, while Stoller®USA treatments were evaluated at 36K, 38, and 40K seeding rates using both Pioneer® 1108Q and Integra™ 6493VT2P. Control received -40# N (180# total) and only one (VT) foliar fungicide pass, and 200# each of 18-46-0 and 0-0-60.

High yield treatments received 13.7oz/A. of Miravis® Neo at VT and 13.7oz/A. of TrivaPro® at R3 growth stage, +40 additional N units and water conditioner.

Results: Integra 6493VT2Pro achieved both agronomic and economic optimum seeding at 40K, with yields of 269.0 Bu/A., +27.1 Bu/A. over control, and net returns of +\$41.08/A. Both yield and return increased as seeding rates climbed.

Pioneer 1108Q posted both agronomic and economic optimum seeding rate at 38K with yield of 264.4 Bu/A., +19.3 Bu/A. over control, and net returns of +\$8.42/A.

Excellent overall yield response, however cost of program dampened net returns.



Planting Date: April 27th Hybrids: Pioneer 1108Q, Integra6349VT2P Population: 36K,38K,40K Row Width: 30" Rotation: CAB Corn Price: \$5.31
 Conceal® Program: \$4.59/A. FurrowJet® Program: \$19.34/A. Post Program: \$169.79/A. DAP/Potash: \$870/\$770 N Price: \$0.88/# (\$35.20/A.)
 Fungicide+Water Conditioner: \$30.40/A. Seed Cost:\$350/Bag

Irrigated vs Dryland FurrowJet®/Conceal® ROI Analysis

Objective: To evaluate the difference in return on investment of at-plant FurrowJet® and Conceal® (Figures 1-2.) nutritional programs in both irrigated and dryland environments.

It is a common question at the PTI Farm for growers to ask if the yield and economic response of at-plant treatments of FurrowJet® and Conceal® is similar in both irrigated, as well as dryland environments? This study evaluates the 2023 high yield corn management trials and isolates the difference in return on investment (ROI) of irrigated versus dryland programs.

Results: Irrigated environments offered average return on investment of +9.9% in FurrowJet and Conceal programs. In dryland treatments where overall yield potential was lower, average return on investment remained positive at +6.7%. Both environments proved profitable, however irrigated treatments offered an advantage of +3.2% additional returns.

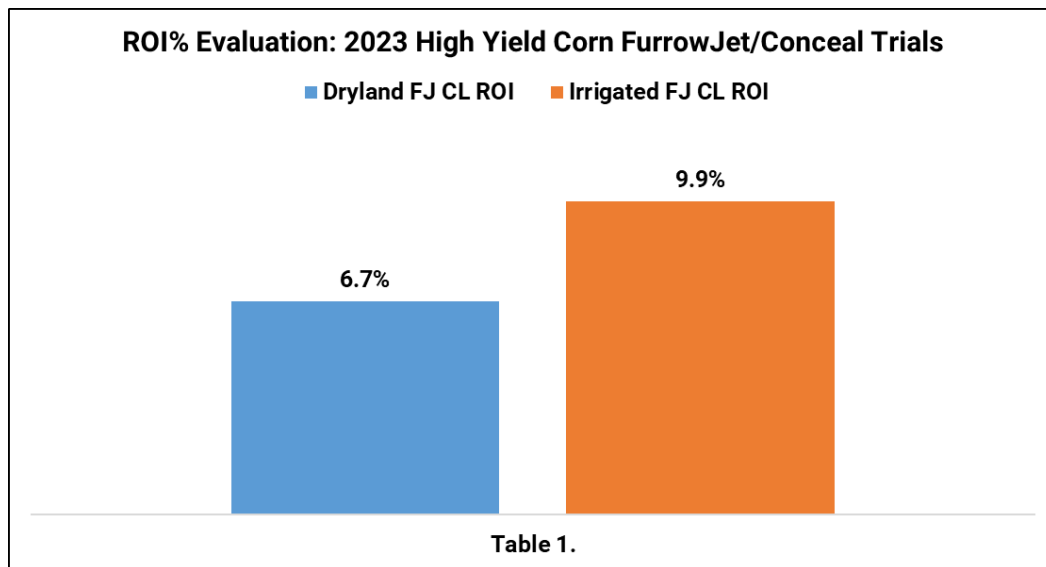


Figure 1. Conceal® Placement



Figure 2. FurrowJet® Placement



Nachurs® Fertilizer Ultra-High Management Nutritional Study

Objective: To evaluate the yield and economic impact of a corn liquid starter fertilizer and foliar nutritional program from Nachurs® in a high management irrigated environment. This trial was designed as an ultra-high management program designed for maximum potential yield. Treatments consisted of the following:

Treatments and Placement:


#1. Control:	200# DAP, 200# 0-0-60, Less R3 Fungicide, Less 40# N
#2 At-Plant Fertility:	
Conceal® Dual Band (Figure 1.)	27 Gal/A. UAN, 5 Gal/A. Throwback®, 3 Gal/A. K-fuse®, 1 Gal/A. SideSwipe®
FurrowJet® Center: (Figure. 2.)	1Pt/A. Rhyzo-Link® PE, 1.5 Gal/A. Balance® 2Qt/A. K-fuel®, 1 Qt/A. Face Off®, 1oz/A. NLT 5.1
FurrowJet® Wings: (Figure. 2.)	6 Gal/A. Nachurs First Down®, 1Qt/A. Humi-Flex Max® 1Qt/A. Calcium
#3 Foliar Applications:	
	V4: 1Qt FinishLine®, 2Gal TripleOption®, 1Pt Hum-flex®FA
	V6: SideDress 2 Gal K-flex® Max, 1 Gal/A. SideSwipe®
	V10: 1 Gal K-fuel®, 1Qt Nachurs FinishLine®
	V12: Fertigation: 4 Gal K-fuel®, 0.5 Gal SideSwipe®
	VT: 1 Gal FirstDown®+ 1 Gal Balance®, 1 Qt/A. Boron
	R2: 1.5 Gal NockOut®, 1 Qt/A. Face Off®
	R3: Fertigation: 4 Gal/A. Aqua-Tech®



Figure 1. Conceal® Dual Band Placement

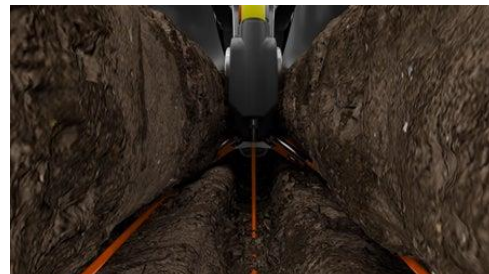


Figure 2. FurrowJet® Placement

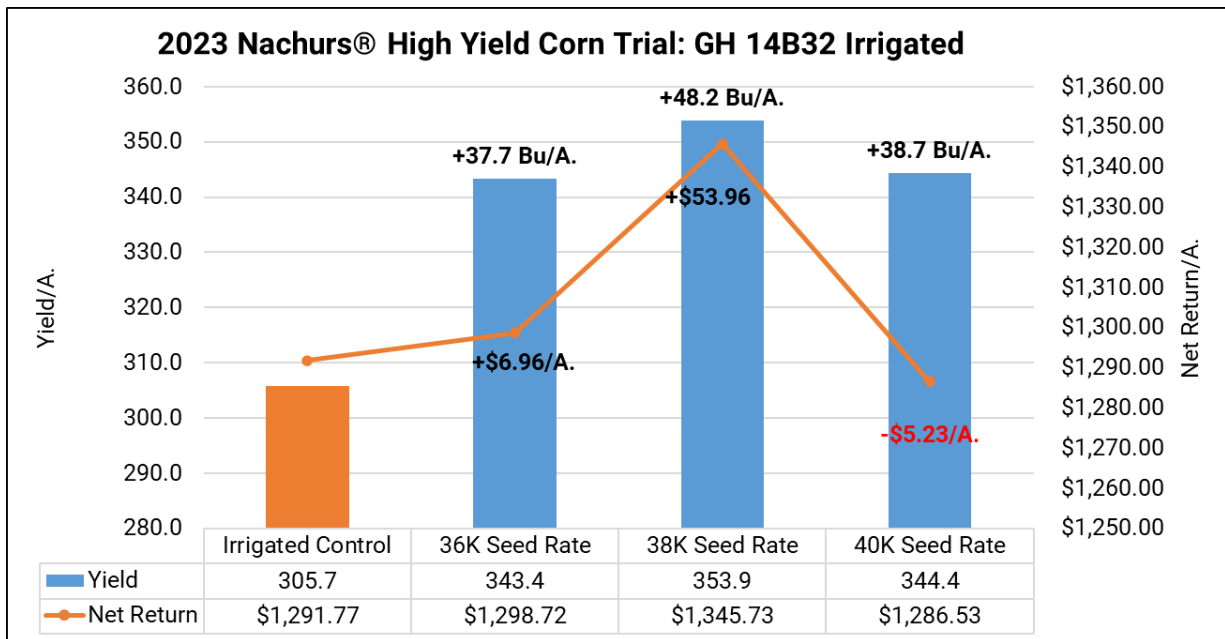
Nachurs® Fertilizer Ultra-High Management Nutritional Study

All controls were planted at 36K seeding rates, while Nachurs treatments were evaluated at 36K, 38, and 40K seeding rates using both Pioneer® 0924 and Golden Harvest® 14B32. Controls received -40# N (250# total), only one (VT) foliar fungicide pass, with fertility of 200# each of 18-46-0 and 0-0-60 applied in the fall in a strip-till band.

Irrigation on all treatments received 6" water throughout the growing season. High yield treatments received 13.7oz/A. of Miravis® Neo at VT and 13.7oz/A. of TrivaPro® at R3 growth stage, +40 additional N units and water conditioner.

Results: Golden Harvest® 14B32 obtained ridiculous yield levels at 305.7 to 353.9 Bu/A. The response of this corn hybrid was amazing in high management situations. Both agronomic and economic optimum seeding rate was achieved at 38K with yield advantages of +48.2 Bu/A. and economic return of +\$53.96/A. over the control.

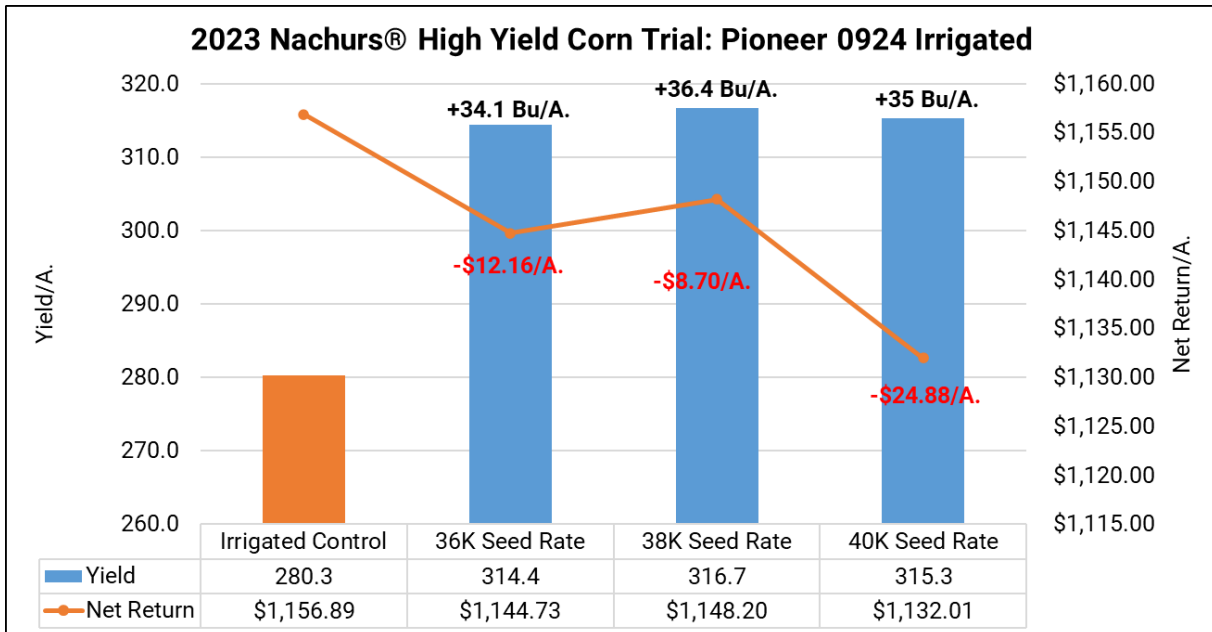
However, even though hybrid response was incredible at +37.7 to +48.2 Bu/A., economic losses occurred due to ultra-high cost of the fertility program (\$301.63/A.) The fact that this hybrid nearly broke even, is unfathomable.



Nachurs® Fertilizer Ultra-High Management Nutritional Study

Pioneer® 0924 obtained yield levels at 280.3 to 316.7 Bu/A. Agronomic high yield occurred at 38K seeding rates, however a range of only 1.4 to 2.3 Bu/A. occurred between all three populations.

All seeding rates tallied economic losses ranging from **-\$8.70/A.** to **-\$24.88/A.**, even though hybrid response from the overall fertility was incredible at +34.1 to +36.4 Bu/A.



Even though economic return was only achievable on two of the six total treatments, overall yield response was exceptional. However, as we are mindful of lack of return on investment coupled with environmental aspects, this fertility approach is simply not sustainable as it stands today. As we fine-tune this program and realize the treatments that maximize yield and return, we can hopefully remove those that are less effective.



Planting Date: April 25th Hybrids: Pioneer 0924, GH 14B32 Population: 36K,38K,40K Row Width: 30" Rotation: CAC Corn Price: \$5.31
 Conceal® Program: \$59.76/A. FurrowJet® Program: \$62.88/A. Post Program: \$178.99/A. DAP/Potash: \$870/\$770 N Price: \$0.88/# (\$35.20/A.)
 Fungicide+Water Conditioner: \$30.40/A. Seed Cost:\$350/Bag

Nachurs® Fertilizer High Management Nutritional Study

Objective: To evaluate the yield and economic impact of a corn liquid starter fertilizer and foliar nutritional program from Nachurs® in a high management irrigated environment. This trial was designed as an ultra-high management program designed for maximum potential yield. Treatments consisted of the following:

Treatments and Placement:


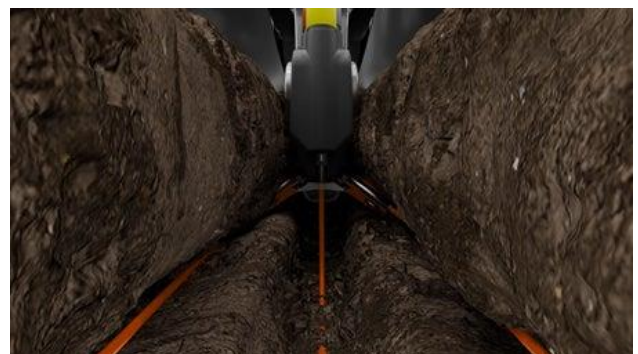
#1. Control:	200# DAP, 200# 0-0-60, Less R3 Fungicide, Less 40# N
#2 At-Plant Fertility:	
Conceal® Dual Band (Figure 1.)	27 Gal/A. UAN, 5 Gal/A. Throwback®, 3 Gal/A. K-fuse®,
FurrowJet® 3-Way: (Fig. 2.)	1.5 Gal/A. Balance®, 2Qt/A. K-fuel®, 1 Qt/A. Face Off®
#3 Foliar Applications:	
	V4: 1Qt FinishLine®, 2Gal TripleOption®
	V6: SideDress 2 Gal K-flex® Max
	VT: 1 Gal FirstDown®+ 1 Gal Balance®, 1 Qt/A. Boron
	R3: 1.5 Gal NockOut®, 1 Qt/A. Face Off®

Figure 1. Conceal® Dual Band Placement



Figure 2. FurrowJet® Placement



Nachurs® Fertilizer High Management Nutritional Study

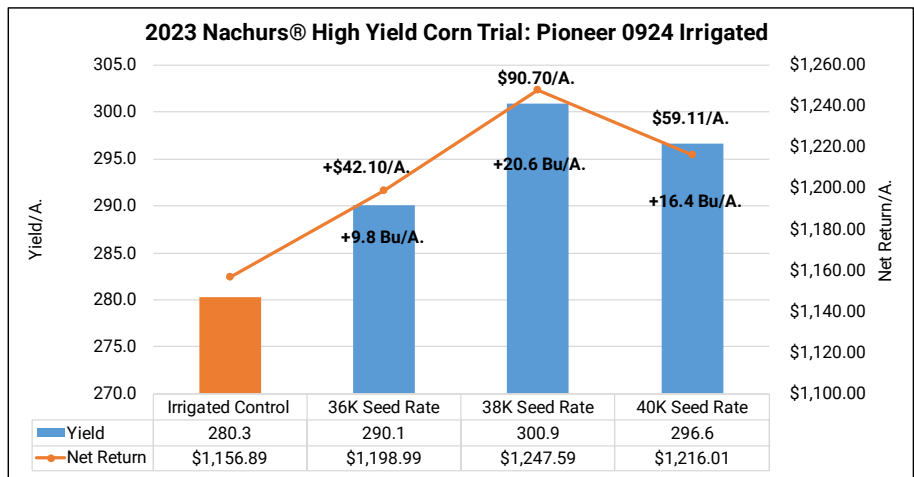
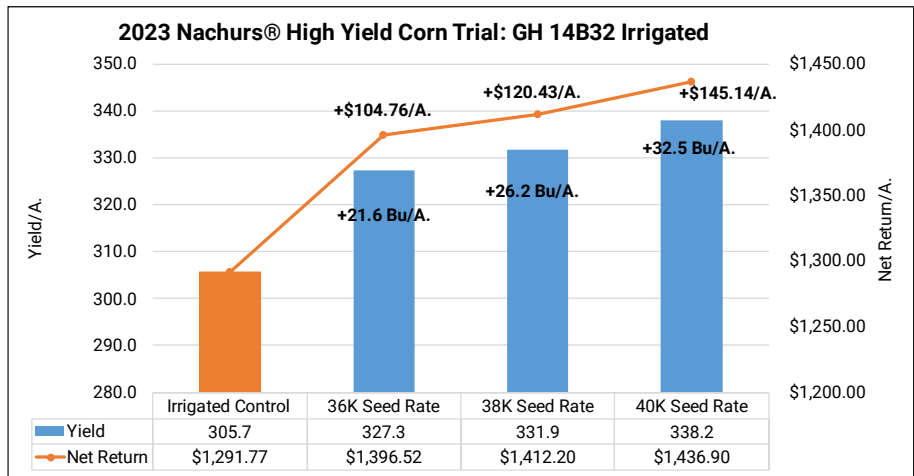
All controls were planted at 36K seeding rates, while Nachurs treatments were evaluated at 36K, 38, and 40K seeding rates using both Pioneer® 0924 and Golden Harvest® 14B32. Controls received -40# N (250# total), only one (VT) foliar fungicide pass, with fertility of 200# each of 18-46-0 and 0-0-60 applied in the fall in a strip-till band.

Irrigation on all treatments received 6" water throughout the growing season. High yield treatments received 13.7oz/A. of Miravis® Neo at VT and 13.7oz/A. of TrivaPro® at R3 growth stage, +40 additional N units and water conditioner.

Results: Golden Harvest® 14B32 obtained excellent yield levels at 305.7 to 338.2 Bu/A. The higher the seeding rate, the higher the yield and economic return. 38K pops tallied yield increase of +32.5 Bu/A. with economic gains of +\$145.14/A.

36K and 38K offered exceptional yield gains of 21.6 to 26.2 Bu/A., along with economic gains of +\$104.76 to +\$120.43/A.

Pioneer 0924 posted both agronomic and economic seeding rate at 38K, with yield of +20.6 Bu/A. and returns of +\$90.70/A. Lowering seed rates to 36K produced losses of **-10.8 Bu/A.** and **-\$48.60/A.** Higher 40K rates lost **-4.2 Bu/A.** and **-\$31.58/A.**



Planting Date: April 25th Hybrids: Pioneer 0924Q, GH 14B32 Population: 36K,38K,40K Row Width: 30" Rotation: CAC Corn Price: \$5.31
 Conceal® Program: \$41.10/A. FurrowJet® Program: \$14.03/A. Post Program: \$63.21/A. DAP/Potash: \$870/\$770 N Price: \$0.88/# (\$35.20/A.)
 Fungicide+Water Conditioner: \$30.40/A. Seed Cost:\$350/Bag

NewFields Ag™/NMS High Management Corn Study: Irrigated

Objective: To evaluate the yield and economic impact of a corn liquid starter fertilizer and foliar/biological nutritional program from NewFields Ag™ and Nutrient Management Specialists (NMS) in a high management irrigated environment. This trial consisted of the following:

Treatments and Placement:

#1. Control:	200# DAP, 200# 0-0-60, Less R3 Fungicide, Less 40# N	
#2 At-Plant Fertility:	Terrasym 450 + DUST: Hopper Box Treatment	
FurrowJet® Center: (Figure 1.)	16oz/A. Rizosphere:	Microbial Fermentation Manure/Kelp
	16oz/A. Phenom®:	Endophyte Bacterial N Efficiency
	16oz/A. IonFx™:	Bacteria, Archaea, and Fungi
	NMS Mix:	Fish, Kelp, Sea Crop, + Fulvic Acid
FurrowJet® Wings: (Figure 1.)	16oz/A. Frenzy™:	Antioxidant Enzyme
		Stress Mitigation
	NMS Mix:	Seeder Heater, Moly,Yucca, Zn/Mn SO4
Conceal® Dual Band: (Figure 2.)	NMS Mix:	9-45-15 w/Micros
#3 Foliar Applications:	V4: NewFields	16oz/A. Frenzy™
	VT: NMS Mix:	26-8-16 w/Micros
	R3: NMS Mix:	26-8-16 w/Micros

Figure 1. FurrowJet® Placement



Figure 2. Conceal® Dual Band Placement



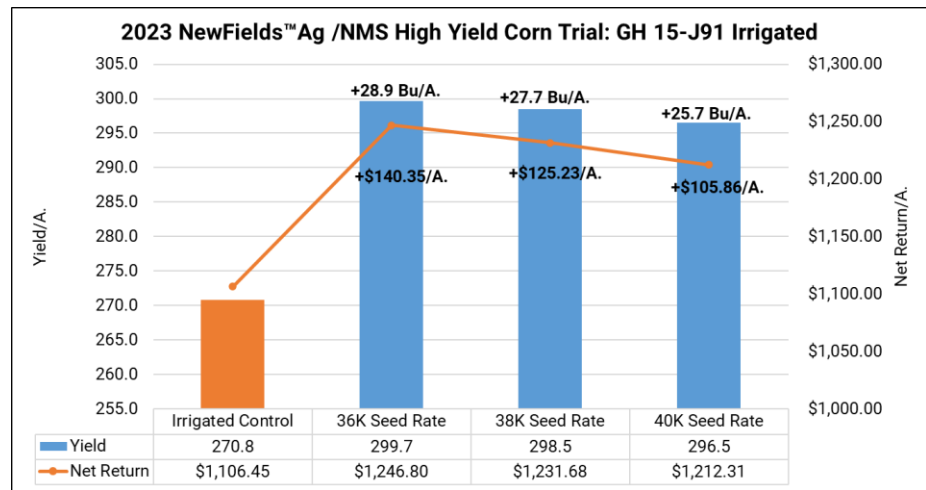
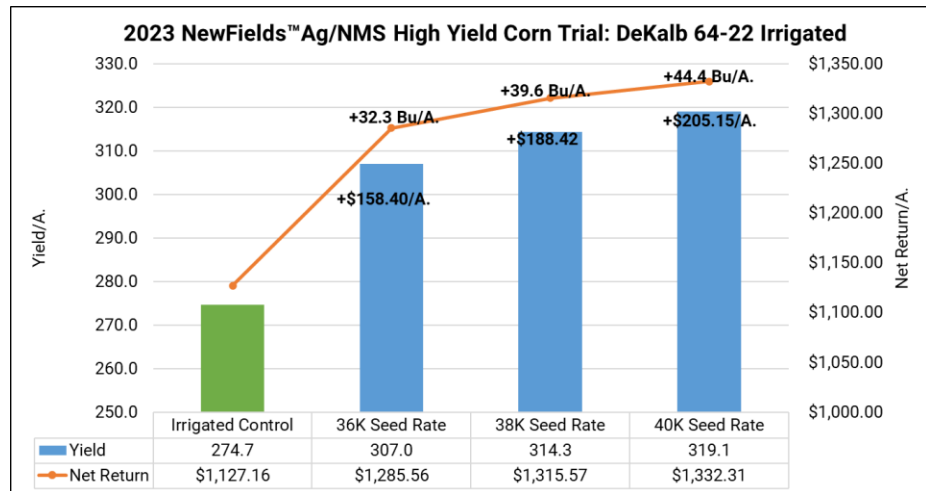
NewFields Ag™/NMS High Yield Study: Irrigated Continued

All controls were planted at 36K seeding rates, while NewFields Ag™/NMS treatments were evaluated at 36K, 38, and 40K seeding rates using both Golden Harvest 15J91 and DeKalb 64-22.

Irrigation on all treatments received 6" water throughout the growing season. All treatments received 13.7oz/A. of Miravis® Neo at VT and 13.7oz/A. of TrivaPro® at R3 growth stage.

Results: DeKalb 64-22 tallied exceptional yields averaging 274.7 to 319 Bu/A. Seedings rates should have been increased over 40K to fully understand agronomic and economic optimum, however highest yield and return came at 40K seeding rates with a yield of 319.1 Bu/A. and returns of +\$205.15/A. 40K seeding rates provided +12.1 Bu/A. over the low 36K rate.

Golden Harvest 15J91 offered both agronomic and economic return at the lowest 36K seeding rate with a yield of 299.7 Bu/A. and returns of +\$140.35/A. Yields only varied by 3.2 Bu/A. from high to low pops.



Planting Date: April 25th Hybrids: DeKalb 64-22VT2Pro, GH 15J91 Population: 36K,38K,40K Row Width: 30" Rotation: CAC Corn Price: \$5.31
 High Yield Program: \$121.51/A. DAP/Potash: \$870/\$770 N Price: \$0.88/# (\$35.20/A.) Fungicide+Water Conditioner: \$30.40/A.

NewFields Ag™/NMS High Management Corn Study: Dryland

Objective: To evaluate the yield and economic impact of a corn liquid starter fertilizer and foliar/biological nutritional program from NewFields Ag™ and Nutrient Management Specialists (NMS) in a high management irrigated environment. This trial consisted of the following:

Treatments and Placement:

#1. Control:	200# DAP, 200# 0-0-60, Less R3 Fungicide, Less 40# N	
#2 At-Plant Fertility:	Terrasym Dust 450: Hopper Box Treatment	
FurrowJet® Center: (Figure 1.)	16oz/A. Rizosphere:	Microbial Fermentation Manure/Kelp
	16oz/A. Phenom®:	Endophyte bacterial N efficiency
	16oz/A. IonFx™:	Bacteria, Archaea, and Fungi
	NMS Mix:	Fish,Kelp,Sea Crop, + Fulvic Acid
FurrowJet® Wings: (Figure 1.)	16oz/A. Frenzy™:	Antioxidant Enzyme
		Stress Mitigation
	NMS Mix:	Seeder Heater, Moly,Yucca, Zn/Mn SO4
Conceal® Dual Band: (Figure 2.)	NMS Mix:	9-45-15 w/micros
#3 Foliar Applications:	V4: NewFields	16oz/A. Frenzy™
	VT: NMS Mix:	26-8-16 w/micros
	R3: NMS Mix:	26-8-16 w/microR3:
	NMS Mix:	26-8-16 w/micros

Figure 1. FurrowJet® Placement



Figure 2. Conceal® Dual Band Placement



NewFields Ag™/NMS High Yield Study: Dryland Continued

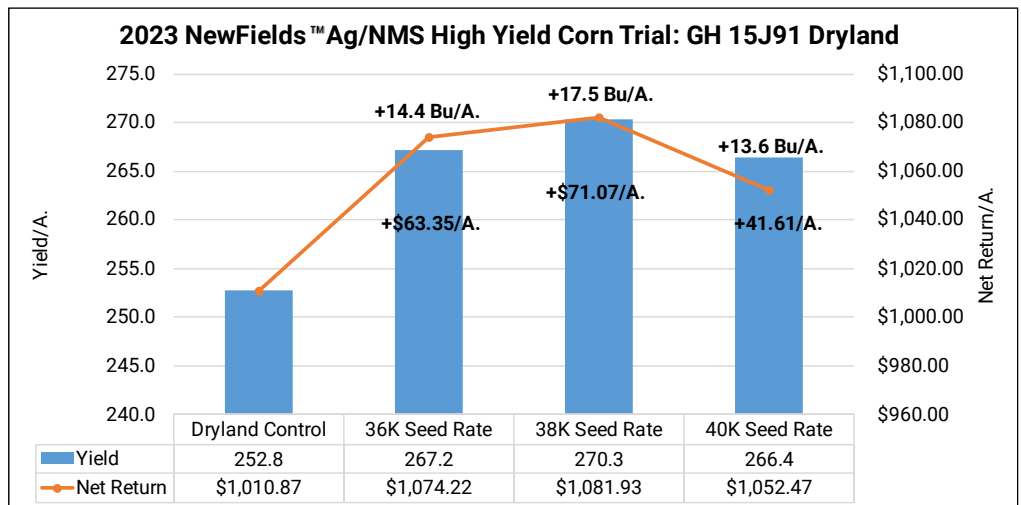
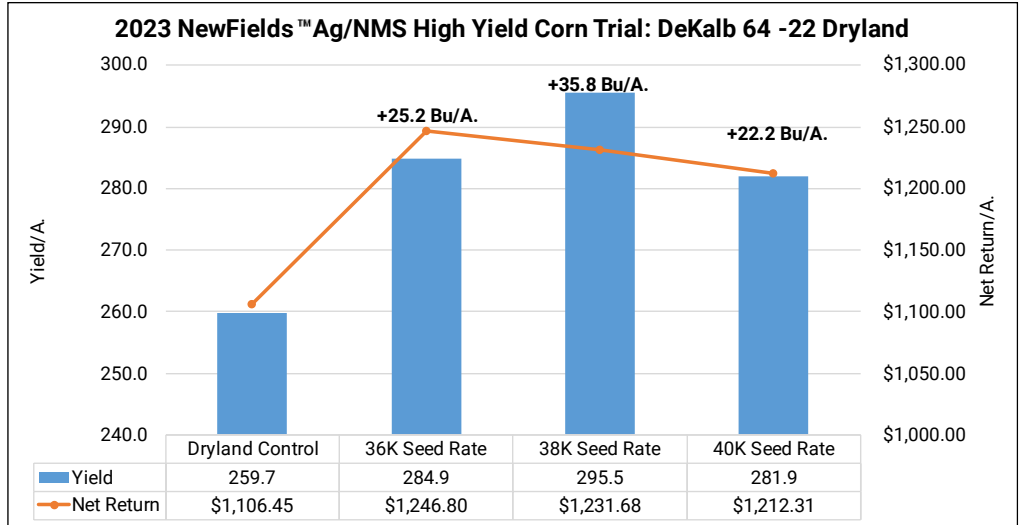
All controls were planted at 36K seeding rates, while NewFields Ag™/ NMS treatments were evaluated at 36K, 38, and 40K seeding rates using both Golden Harvest 15J91 and DeKalb 64-22.

All treatments received 13.7oz/A. of Miravis® Neo at VT and 13.7oz/A. of TrivaPro® at R3 growth stage.

Results: DeKalb 64-22 achieved stellar yields in this dryland study with yields just under 300 Bu/A. Both agronomic and economic optimum were achieved at the 38K seeding rate with yield at 295.5 and return of +\$168.24/A.

Driving seeding rate from 36K to 38K, resulted in yield gains of +10.6 Bu/A., while pushing to 40K decreased **-13.6 Bu./A.**

Golden Harvest 15J91 offered both agronomic and economic return at the lowest 36K seeding rate with a yield of 270.3 Bu/A. and returns of +\$71.07/A. Yields only varied by 3.9 Bu/A. from high to low pops.



Organic Corn Study

Objective: To evaluate the yield and economic impact of an organic corn management program compared to conventional farming practices.

This trial focuses on introducing organic farming practices at the PTI Farm. If there is a current or future market for organic corn and buyers are willing to pay farmers a premium for it, we feel it prudent to challenge the status quo of conventional farming practices to that of organic. This is the first true organic transition year at the PTI Farm.

Below are the parameters on how each management system will be evaluated for yield and cost:

Treatments:

Conventional Program:

Tillage:	Fall Disk Ripper/Spring Soil Finisher
Dry Fertilizer Fall Applied:	200# 18-46-0, 200# 0-0-60
240# Nitrogen:	25% Weed-N-Feed, 25% Conceal®, 50% SideDress
Conventional Herbicide:	2 Pass Pre/Post
Traited Seed:	\$350/Bag
Fungicide:	VT Growth Stage Application

Organic Program:

Fall Applied Sea-90:	150# Dehydrated Sea-Water/Sodium Chloride
2 Ton Litter:	Fall Applied Dry Chicken Litter
Treffler Weed Tine:	4 Passes for Weed Control
Row Crop Cultivation:	2 Passes
Organic Seed:	\$315/Bag
Bio-Fungicide:	VT Growth Stage Application
Tillage:	Fall Disk Ripper/Spring Soil Finisher

*All products organic certified

Organic Corn Study

At-Plant and Foliar Organic Fertility:

Conceal® Dual Band: (Figure 1.) 10 Gal/A. QLF® TripleThreatOption 5-5-5
20 Gal/A. Water as Carrier



V12 Foliar: BioXRG K-Ferm 0-0-12 Organic Potassium Acetate

V12: EZ Drops™ SideDress 10 Gal/A. QLF® TripleThreatOption: Carbon from Sugar Cane Molasses (TerraFed™) and available Nitrogen (3%) in Ammoniacal form, formulated in a 5:1 C:Ratio

*All products organic certified

Figure 1. Conceal® Dual Band Placement



Figure 2. Treffler Weed Tine



Figure 3. Row Crop Cultivation



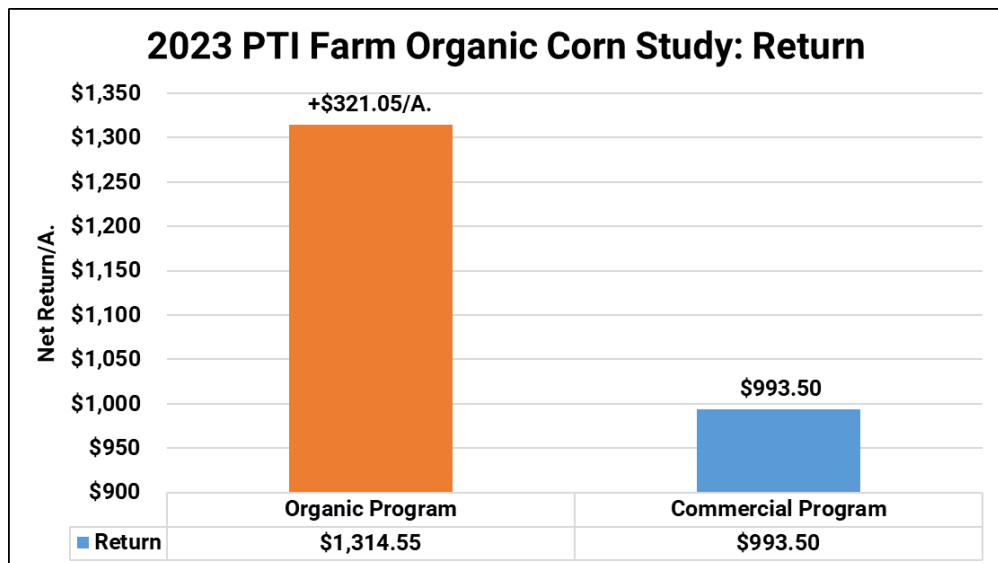
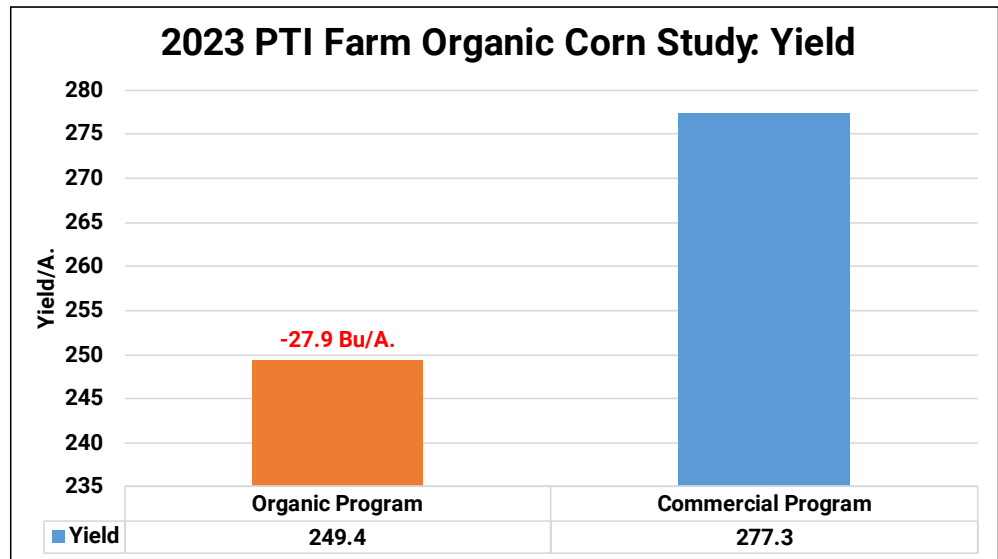
Figure 4. EZ-Drops™



Organic Corn Study

Results: The organic program proved overall yield losses of **-27.9 Bu/A**, compared to a status quo traditional commercial program. Seeing these yield losses may cause some hesitation for organic corn, however the true story lies in overall economics of the two programs. Using a \$7/Bu. sale price, organic corn posted an additional positive return on investment of **+\$321.05/A.** over the conventional program.

Overall the organic corn program was a huge success. Going into 2023, our main concern was weed control. Going into 2024, weed control will still be a major concern. However, with the use of the Treffler weed tiner and the row crop cultivation, we were able to control weeds very well. We know this could be a major problem each each year. We look forward to advancements in technology for weed control and general nutrition to improve our organic program in the future.



Planting Date: May 15th Population: 36K Row Width: 30" Rotation: CAB Corn Price: \$5.31/\$7.00

Conventional Program: \$478.97/A. Organic Program: \$431.25/A .

High Management Corn Ocean Blue Ag Fertility Study

Objective: To evaluate the yield and economics of Ocean Blue Ag’s corn nutrition program. This high management fertility study implements the use pre-plant dry calcium, sea salt, at-plant FurrowJet® and Conceal® liquid nutrition, as well as foliar liquid applications at V3, VT, and R1 growth stages.

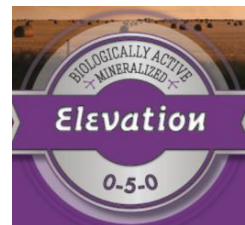
Sea-90™ by SeaAgri, Inc are natural salt crystals produced from sea water mined from the Sea of Cortez in Mexico. It is dehydrated seawater in its purest state containing 75-80 percent sodium chloride containing 90 plus elements including sodium, potassium, calcium, and magnesium and balanced with trace elements including copper, chromium, zinc, manganese, selenium, cobalt, molybdenum.

Elevation 0-5-0 is an early V3 foliar feed that contains long lasting bio-stimulated catalyst and phosphoric acid that helps pollination, blossom retention and fruiting.

IPS 100 is a superior non-ionic, surfactant, spreader sticker, and soil penetrant mixed in a proprietary nutrient complex base performing various functions in agriculture. It is also a superior penetrant to help loosen tight soils allowing better aeration and water movement in the root zone.

Nutri-Shield 0-7-0 is applied in-furrow and contains vitamin hormone enzymes, rooting acids, chelated trace minerals, and humic acids. It helps provide for immediate growth energy, promotes stronger roots and suppresses insect feeding.

Power Pro N is applied as a tank-mix with 32% UAN at side-dress and is a soil nutrient enhancer and natural nitrogen stabilizer that revives soil microbiology and improves nitrogen efficiency.



Ocean Blue Ag Fertility High Management Study

The following treatments were made as a part of a sequential step-up program to help evaluate single applied programs as well as combination programs:

*All treatments received foliar treatment of fungicide at VT growth stage.

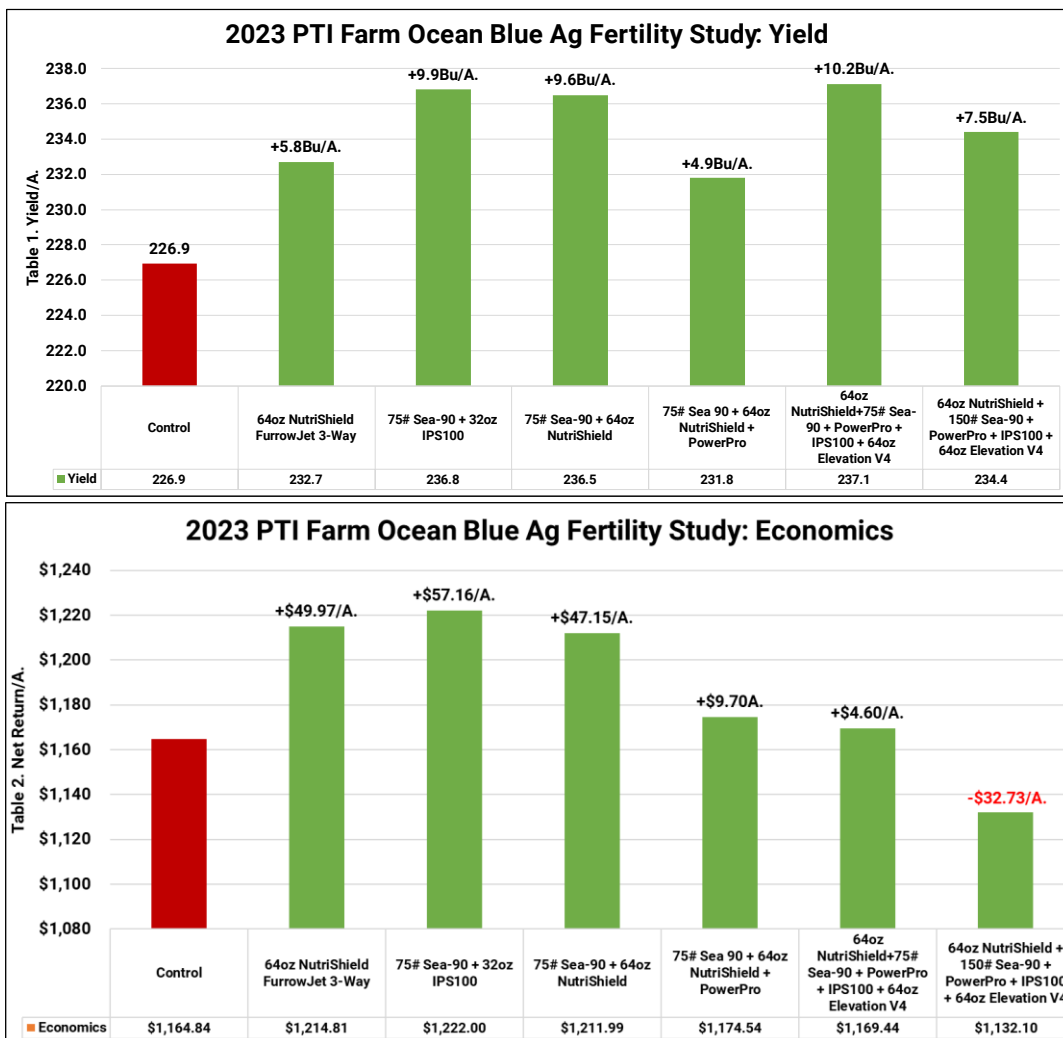
<u>Program</u>	<u>Treatment</u>	<u>Application Timing</u>	<u>Placement of Fertilizer</u>
1	Control	None	None
2	64oz Nutri-Shield FurrowJet®	At-Plant in Furrow	FurrowJet® Tri-Band
3	75# Sea-90 + 32oz IPS 100	Pre-Plant	Broadcast Spinner Pre-Broadcast Spray
4	64oz Nutri-Shield FurrowJet® 75# Sea-90	At-Plant In-Furrow Pre-Plant	FurrowJet® Tri-Band Broadcast Spinner
5	64oz Nutri-Shield FurrowJet® 75# Sea-90 85oz Power Pro	At-Plant In-Furrow Pre-Plant At-Plant Conceal®	FurrowJet® Tri-Band Broadcast Spinner Conceal® Dual Band
6	64oz Nutri-Shield FurrowJet® 75# Sea-90 85oz Power Pro IPS 100 64oz Elevation	At-Plant In-Furrow Pre-Plant At-Plant Conceal® Pre-Plant V4	FurrowJet® Tri-Band Broadcast Spinner Conceal® Dual Band Pre-Broadcast Spray Foliar Broadcast Spray
7	64oz Nutri-Shield FurrowJet® 150# Sea-90 85oz Power Pro IPS 100 64oz Elevation	At-Plant In-Furrow Pre-Plant At-Plant Conceal® Pre-Plant V4	FurrowJet® Tri-Band Broadcast Spinner Conceal® Dual Band Pre-Broadcast Spray Foliar Broadcast Spray



Ocean Blue Ag Fertility High Management Study Continued

Results: Table 1. summarizes all Ocean Blue Ag products proved positive yield gains ranging from +4.9 to +10.2 Bu/A. Between all 6 of the treatments, there was only a 5.3Bu/A. spread, thus having similar yields across the different programs.

Table 2. illustrates the telling story around the economics of the treatments. While all treatments provided positive yield gains, one treatment proved a negative net return of **-\$32.73/A.** The first three treatments proved high net returns of +\$49.97/A., +\$57.16/A., and +\$47.15/A. respectively. This was due to the lower cost of the product being used in those treatments. The last 3 treatments resulted in yield gains like that of the first 3, but due to a higher cost of overall product, they resulted in lower net returns. Those being +\$9.70/A, +\$4.60/A, and **-\$32.73/A.**



Planting Date: June 15th Hybrid: GH 03R40 Population: 36K Row Width: 30" Rotation: CAB Corn Price: \$5.13 \$30 Fertilizer Reallocation

PowerPro: \$12.49/A. NutriShield: \$20.83/A. Elevation: \$20.83/A. Sea-90: \$610/Ton.

Short Corn Fertility/Plant Height Study

Objective: To evaluate the use of Bayer’s short corn technology to understand overall yield and plant height response to a starter fertilizer program.

Short corn is a new platform of corn that is designed to be short in stature. The main advantage of short corn is that it is more resistant to wind. Shorter corn is less of a “sail” during a windstorm and the overall result could be less down corn. Another advantage is the fact that the need for a high clearance sprayer might be diminished.

With this shorter corn, the overall plant height is decreased below the ear. To do this, all of the nodes below the ear are stacked or much closer together that traditional “taller corn”. (Figure 2.)

Disadvantages of short stature are still being evaluated, however the focus of this study resides upon ear height and specifically how close it is to the ground. Low ear height could possibly cause harvestability challenges. The fertility aspect of this study is trying to use nutritional products at-plant, to manipulate the corn to extend ear height.

Yield is also a concern. Short corn is designed with determinate ears that are best planted at higher populations., in fact this study is planted at 40,000 seeds/A.

As these populations increase, seed costs also go up . In order to justify this additional cost, monitoring any yield loss or drag will be important to identify.



Figure 1. Short Corn Left, Traditional Taller Corn Right



Figure 2. Nodes Below Ear Are Closer Together

Short Corn Fertility/Plant Height Study Continued

The at-plant starter fertilizer used for this study includes the following:

Treatments and Placement:

#1. Control:	20 Gal/A. 32% UAN Pre-Plant
#2 At-Plant Conceal Fertility:	
Conceal® Dual Band: (Figure 1.)	20 Gal/A. 32% UAN
	3 Gal/A. Ammonium Thiosulfate
	2 Qt/A. 10% Boron
#3 At-Plant Conceal Fertility:	
FurrowJet® 3-Way: (Figure 2.)	8 Gal/A. 10-34-0
	5oz/A. Ascend® PGR
	2Qt/A. Zinc

Figure 1. Conceal Placement



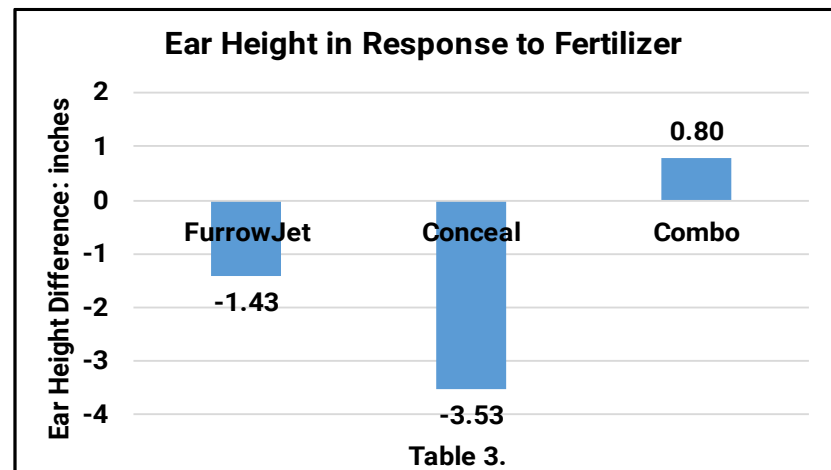
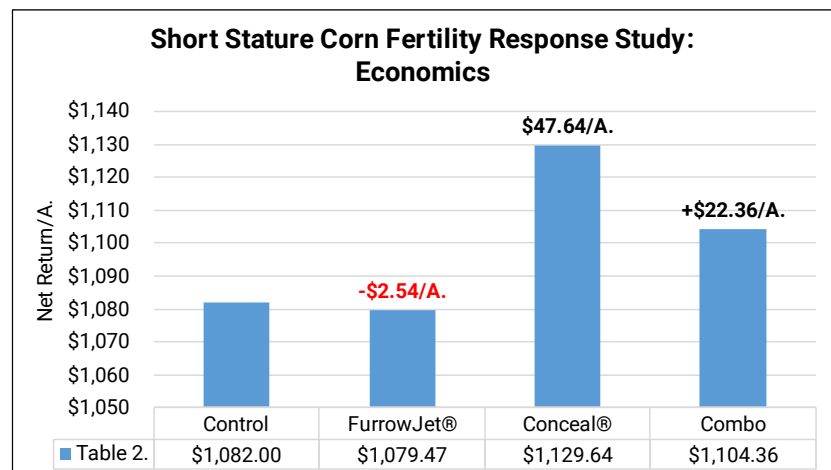
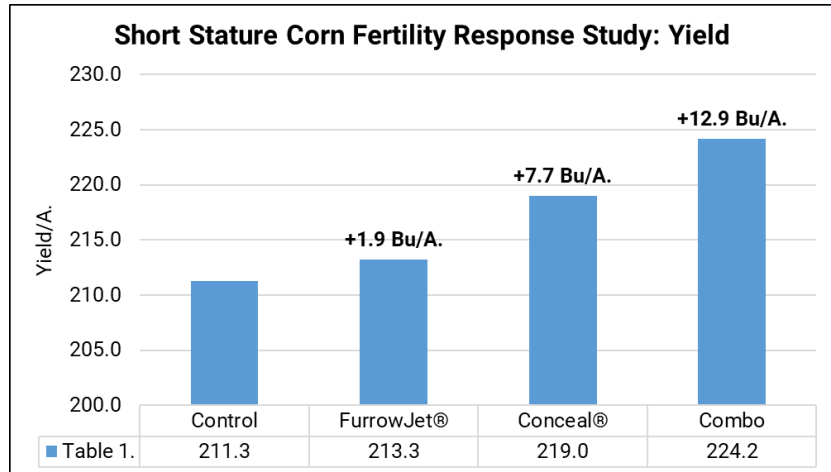
Figure 2. FurrowJet® Placement



Results: In regard to overall fertility, Table 1. Illustrates that all at-plant treatments posted positive yield gains of +1.9 to +12.9 Bu/A., however, Conceal and the combination treatment tallied highest gains of +7.7 to +12.9 Bu/A. respectively. As a result, these treatments offered positive economic gains of +\$22.36 to +\$47.64/A. (Table 2).

Short Corn Fertility/Plant Height Study Continued

In regard to ear height, Table 3. illustrates the results of using an at-plant starter package to manipulate the corn plant to achieve higher ear placement. When placing the fertilizer close to the seed using FurrowJet the ear height was shorter by **-1.43** inches. We then moved the placement away from the seed with Conceal the ear height shortened up by **-3.53** inches. The combo treatment when FurrowJet and Conceal were combined the ear height was raised by 0.80 inches.



Marco QuickGrow LTE FurrowJet® Study

Objective: To evaluate the yield and net return of Marco Fertilizer’s QuickGrow LTE 6-20-4-25Zn-2.7S liquid starter fertilizer at rates of 4, 6 and 8 Gal/A. applied in an at-plant 3-way FurrowJet® system. QuickGrow LTE is a 70% polyphosphate and 30% orthophosphate formulation of nitrogen, phosphorus, potassium, sulfur, and 9% Zn.

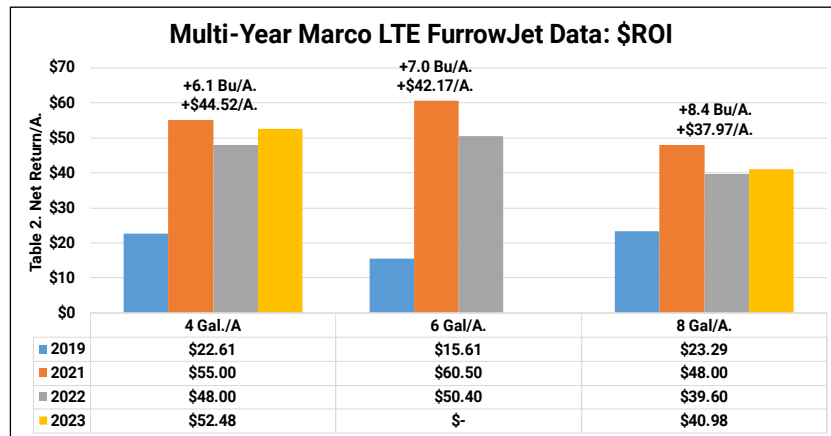
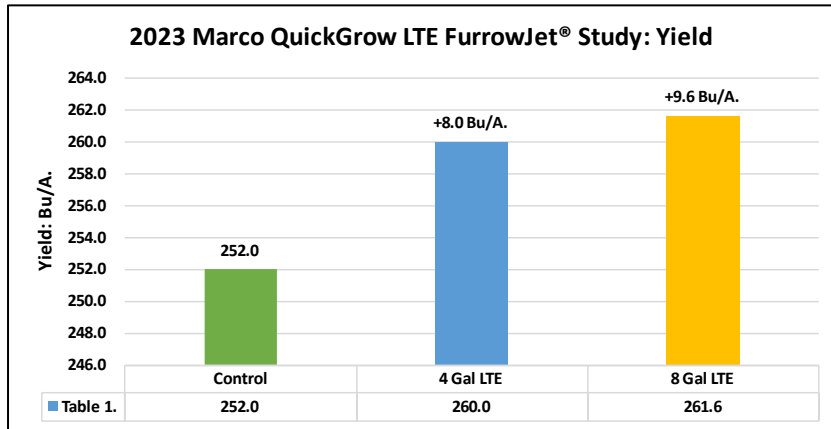
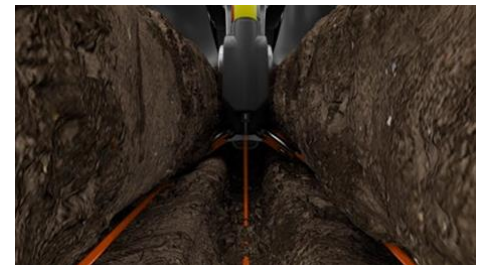


Figure 1. FurrowJet® Placement



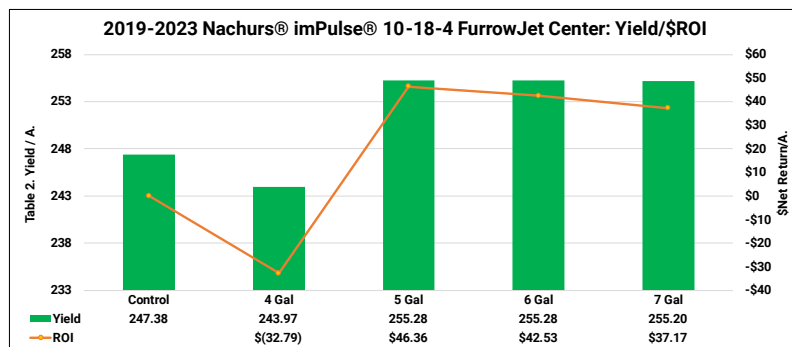
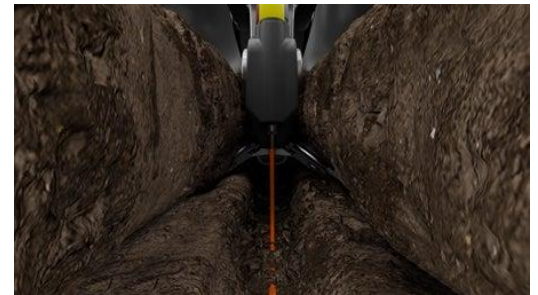
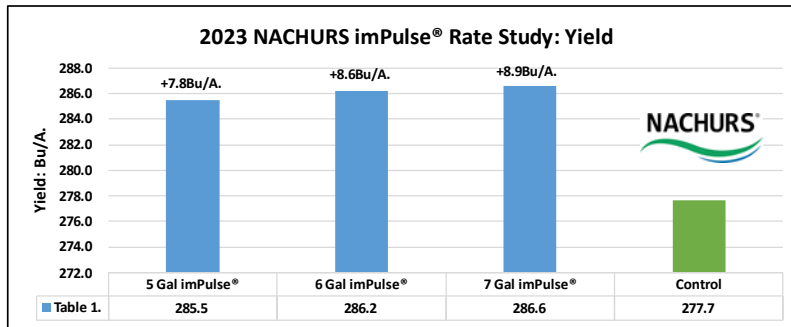
Results: Table 1. illustrates all rates of Marco QuickGrow LTE resulted in positive yield gains. However, 8 Gal/A. rates achieved both agronomic optimum rate, with yield gains of +9.6 Bu/A. and net returns of +\$40.98/A. The 4 Gal/A. rate proved yield gains of +8.0 Bu/A., with corresponding return on investment of +\$52.48/A.

Table 2. summarizes multi-year data, indicating 4 Gal/A. being economic optimum rate over the 2019 to 2023 time period. All applications are implemented with a \$30/A. reallocation.

NACHURS® imPulse® FurrowJet® Center Placement Trial

Objective: To evaluate the effect on yield and economics when NACHURS imPulse® 10-18-4 starter fertilizer (Figure 2.) is placed at 4 to 7 Gal/A. in FurrowJet® **center** only configurations (Figure 1). NACHURS imPulse® is a premium 100% orthophosphate in-furrow liquid fertilizer that contains NACHURS bio-K® technology.

Figure 1. FurrowJet® Placement



10-18-4 Liquid Fertilizer

Nutrients Supplied (pounds per gallon)

Total Nitrogen (N)	1.06
Available Phosphate (P ₂ O ₅)	1.91
Soluble Potash (K ₂ O)	0.42

Derived from: ammonium hydroxide, urea, phosphoric acid, potassium acetate, and potassium hydroxide.

Results: Table 1. illustrate rates of Nachurs imPulse® 10-18-4 at 7 Gal/A. achieved agronomic optimum rate with yield gains of +8.9 Bu/A. along with positive net returns of +\$44.50/A.

Table 2. illustrates multi-year data over 2019-2023 indicating the 5 Gal/A. rate as economic and agronomic optimum over this time period, with an average return on investment of +\$46.36/A.

Pivot Bio PROVEN®40 Liquid Nitrogen Mgt. Study

Objective: To evaluate the effect on yield and economics using Pivot Bio’s PROVEN®40, a nitrogen-producing microbe for corn. These microbes create a symbiotic relationship with the corn plant, producing nitrogen and delivering it directly to the roots of the corn plant.

Microbes then continually feed nitrogen to the corn plant throughout the growing season.

Pivot Bio PROVEN®40 microbes adhere to the roots of the corn plant and support a reliable and consistent method for delivering plant nutrition.

For this agronomic study, nitrogen rate is evaluated at 100% full rates (225#N) as well as -18% N reductions (185# total N or 40# N reduction). Pivot Bio PROVEN®40 was applied in-furrow at planting via FurrowJet® treatments (Figure 1).



Figure 1. FurrowJet® At-Plant



Results: Table 1. illustrates the grower standard control in the study being 100% nitrogen rates (225#N), offering base yields of 235.6 Bu/A. Reducing nitrogen by -40# resulted in losses of **-9.7 Bu/A.** When PROVEN®40 was added to that same nitrogen reduction rate of 185#N, yields improved by +2.6 Bu/A., however still lower than the control by **-7.1 Bu/A.**

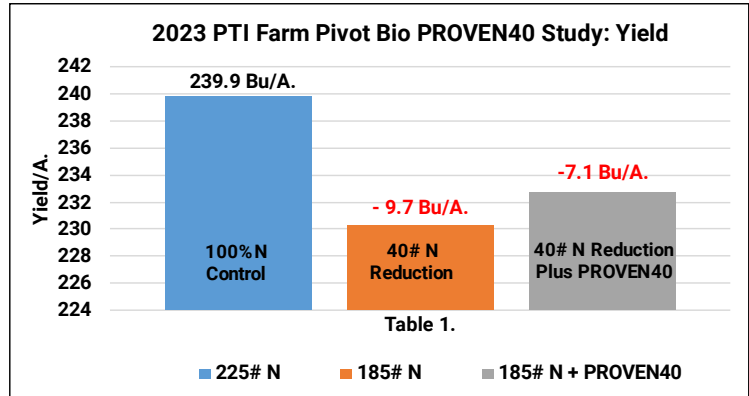
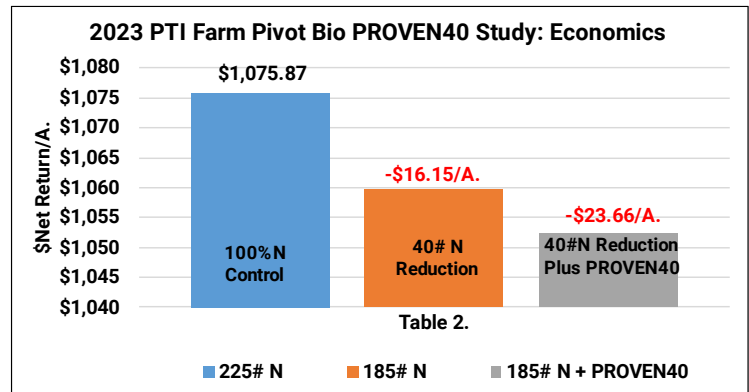


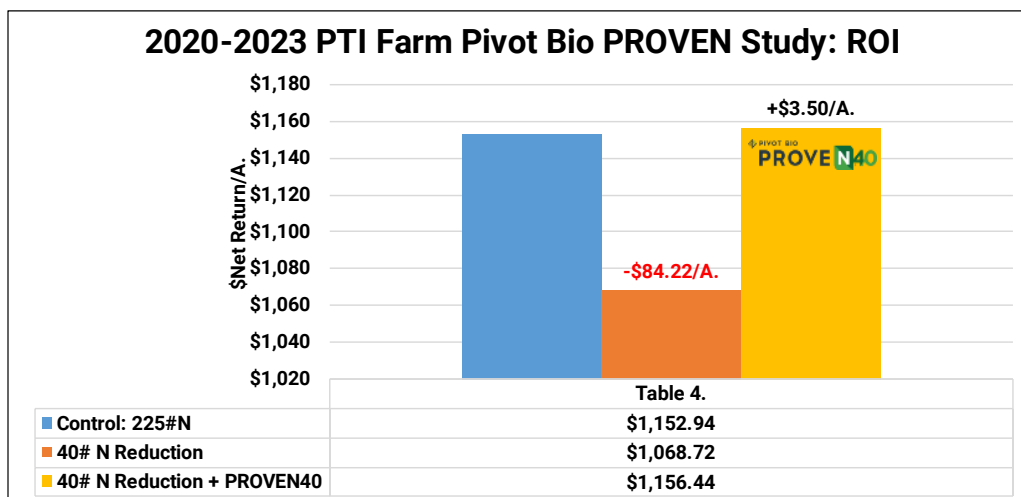
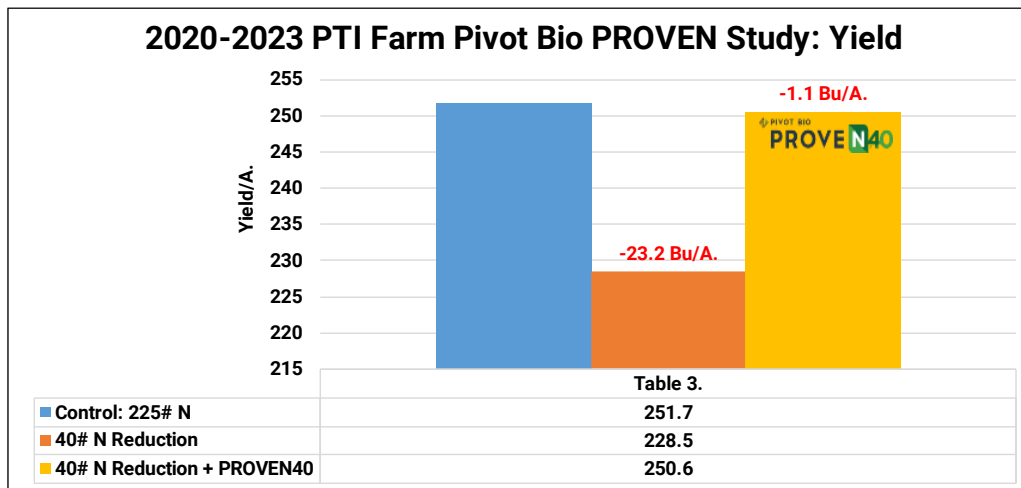
Table 2. reveals the economics of the PROVEN®40 system. Stand-alone -40# nitrogen reductions resulted in economic losses of **-\$16.15/A.**, while tank-mixing PROVEN®40 to along with 40# N reductions resulted in losses of **-\$23.66/A.**



Pivot Bio PROVEN®40 Liquid Nitrogen Mgt. Study Continued

A great feature of the Precision Planting PTI Farm is the ability to capture not just one year of data, but multiple years of data to get a better understanding of consistency and repeatability of a product or technology.

Tables 3-4. illustrate the four year data set summary of Pivot Bio PROVEN®40 over the years of 2020-2023. In this timeframe, reducing nitrogen rate by 40#N, along with the addition of PROVEN®40 applied via FurrowJet® has resulted in yield loss of **-1.1 Bu/A.** , however has generated an additional **+\$3.50/A.** of profitability.

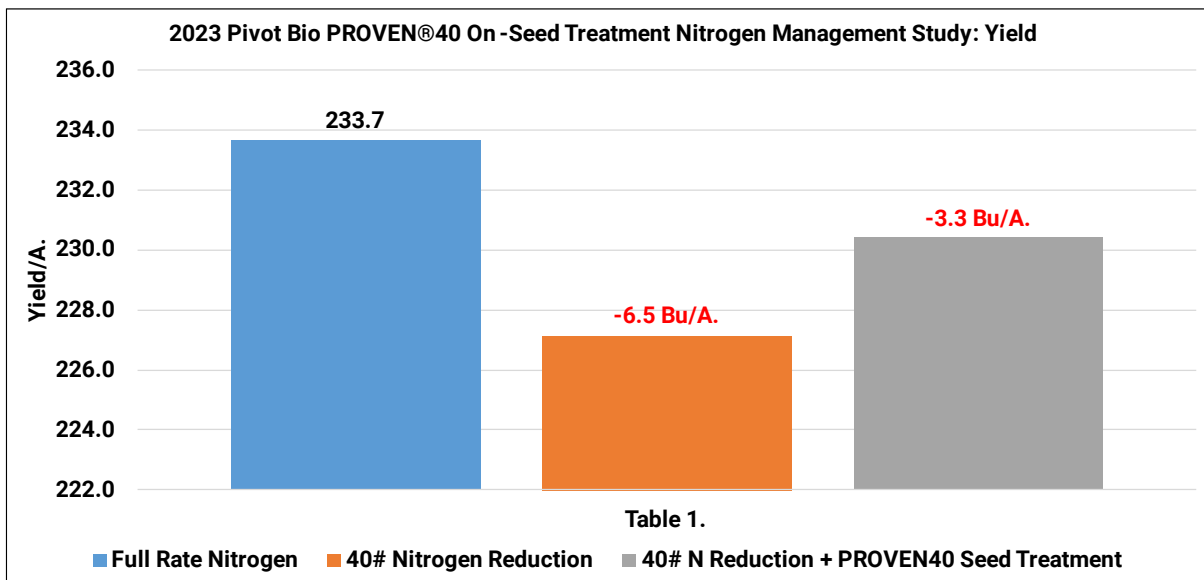


Pivot Bio PROVEN®40 On-Seed Nitrogen Mgt. Study

Objective: To evaluate the effect on yield and economics using Pivot Bio’s PROVEN®40 OS, an on-seed treatment of PROVEN®40, a nitrogen-producing microbe for corn. These microbes create a symbiotic relationship with the corn plant, producing nitrogen and delivering it directly to the roots of the corn plant. Microbes then continually feed nitrogen to the corn plant throughout the growing season. Pivot Bio PROVEN®40 microbes adhere to the roots of the corn plant and support a reliable and consistent method for delivering plant nutrition.



For this continuous corn agronomic study, nitrogen rate is evaluated at 100% full rates (225#N) as well as -40# N reductions (185# Total), with and without PROVEN®40 OS seed treatments.



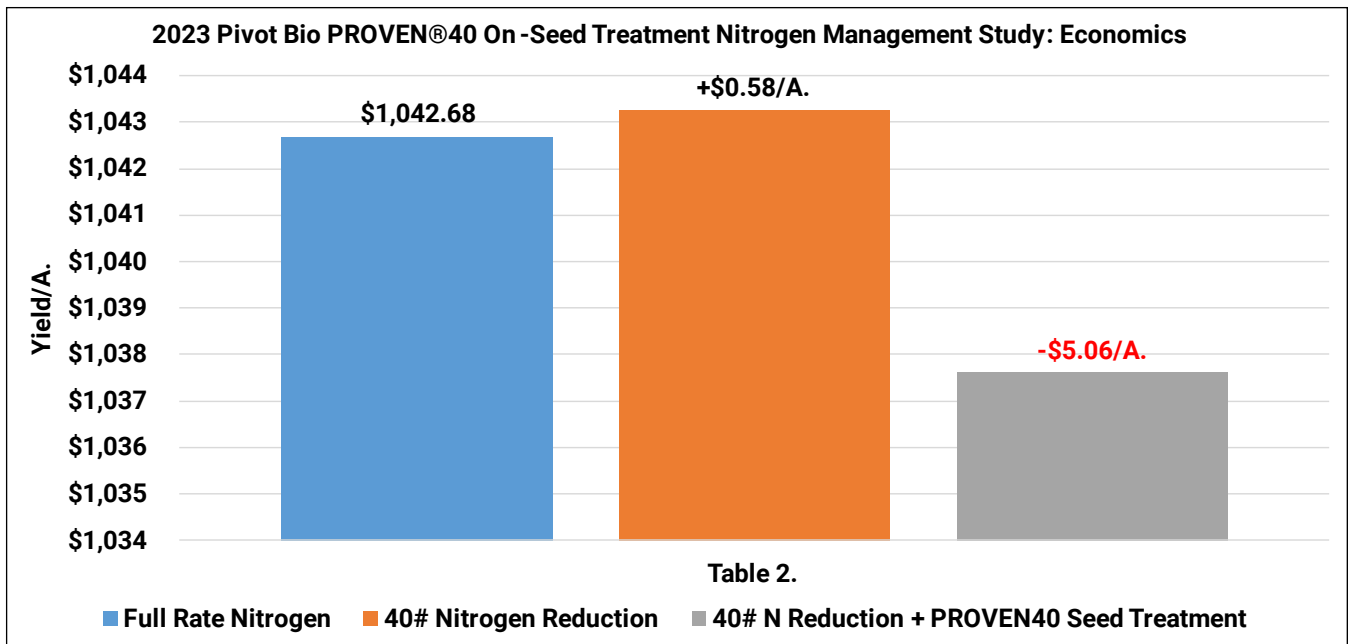
Pivot Bio PROVEN®40 On-Seed Nitrogen Mgt. Study Continued

Results: Tables 1-2. illustrate that 100% full rates of nitrogen provided overall highest yields in this study. PROVEN®40 OS seed treatments resulted in yield losses of **-3.3 Bu/A.** with economic losses of **-\$5.06/A.**

For this continuous corn rotation, it interesting to evaluate the -40# nitrogen reduction. Even though yield suffered **-6.5 Bu/A.**, it proved economic gains of **+\$0.58/A.**, indicating the grower standard practice of 225# of nitrogen could be deemed too high. Consequently, adding a seed treatment of PROVEN40 would not be necessary. In the future, more nitrogen rates may need to be evalauted to fully understand the capacity of PROVEN40 OS.

However, a clear advantage of a seed treatment product is the ability to eliminate tanks, pumps, and other associated liquid equipment on the planter that reduces cost and favors convenience.

2023 was our first year evaluating the seed treatment version of PROVEN®40. We look forward to future evaluations of this nitrogen management product.



Envita® Nitrogen Mgt. Study



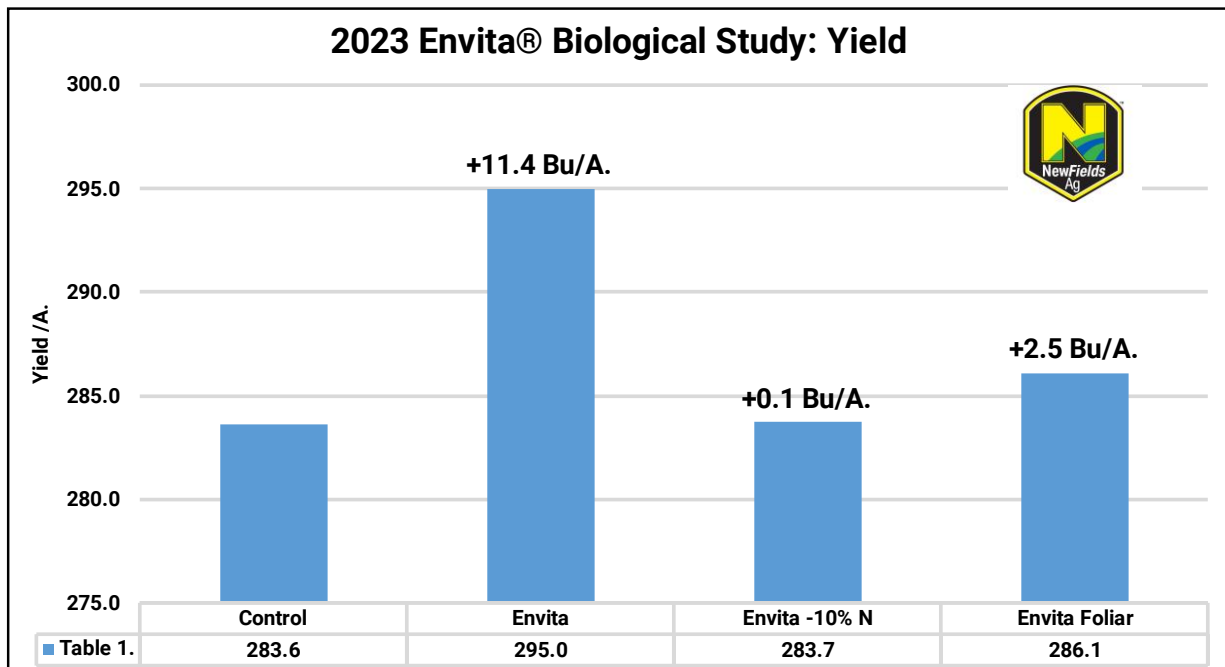
Objective: To evaluate yield and economics of Envita®, applied in-furrow at planting in a FurrowJet® center only application (Figure 1.), at 100% and 90% nitrogen rates, and a foliar V3 application.

Figure 1: FurrowJet® In-Furrow Application



Envita®, distributed by NewFields Ag™, is a naturally occurring, food-grade bacteria (*Gluconacetobacter diazotrophicus*) that was originally discovered in sugarcane. Envita® forms a symbiotic relationship with the host plant and provides nitrogen to cells throughout the plant, both above and below ground, all season long. The use of fertilizers and particularly nitrogen fertilizer is necessary for crop yield and quality. Soybeans and other legume crops have a natural ability to fix nitrogen through their root system, a process supported by rhizobia, which allows inoculated plants to create nodules that fix additional nitrogen in the soil. This practice is commonplace in soybean, but until now there has not been a similar solution for non-legume crops, now there is.

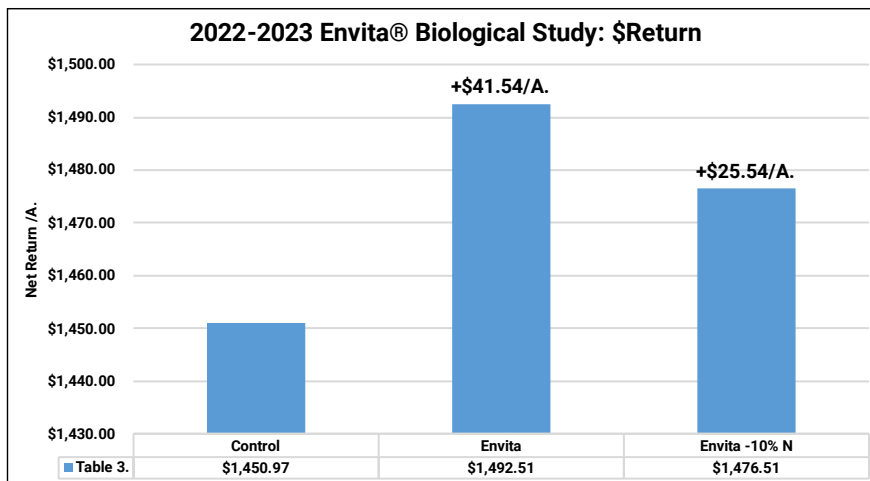
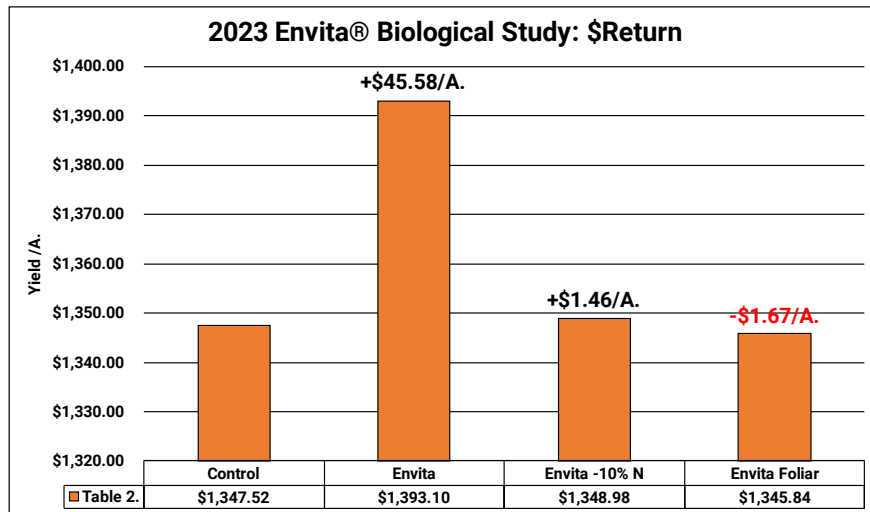
Results: Table 1. illustrates yield gains of +11.4 Bu/A. when Envita® was applied in-furrow along with a standard 100% nitrogen rate. When nitrogen rate was reduced by 10%, yield decreased by **-11.3 Bu/A.** Foliar applications resulted in yield gains of +2.5 Bu/A.



Envita® Nitrogen Mgt. Study Continued

Table 2. illustrates economic gains of +\$45.58/A. when Envita® was applied in-furrow along with a standard 100% nitrogen rate. When nitrogen rate was reduced by 10% in conjunction with Envita®, economic gains fell to +\$1.46/A. Foliar applications resulted in losses of **-\$1.67/A.**

Table 3. depicts 2-year summaries with Envita® in-furrow applications resulting in gains of +\$41.54/A., while Envita® with 10% nitrogen reductions with gains of +\$25.54/A.



Planting Date: April 18th Hybrid:DeKalb 64-22 Population: 36K Row Width: 30" Rotation: CAB Corn Price: \$5.31 Envita: \$14.95/A.

Envita® Nitrogen Mgt. Study PTI Partner Trial



Objective: To evaluate yield and economics of Envita®, applied in-furrow at planting in a FurrowJet® center only application (Figure 1.), at 100% and 90% nitrogen rates, and a foliar V3 application.

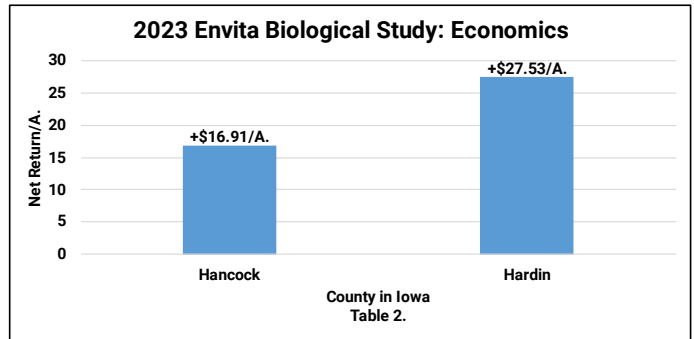
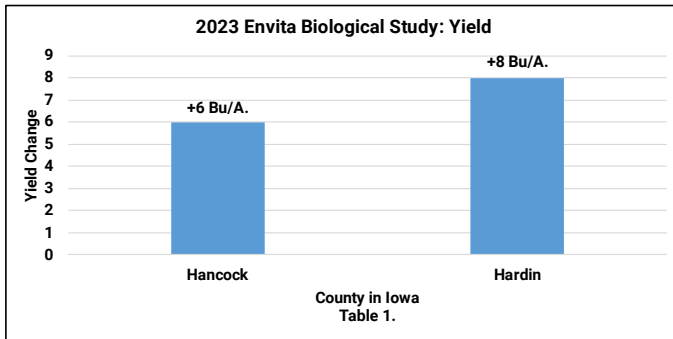
Figure 1: FurrowJet® In-Furrow Application



Envita®, distributed by NewFields Ag™, is a naturally occurring, food-grade bacteria (*Gluconacetobacter diazotrophicus*) that was originally discovered in sugarcane. Envita® forms a symbiotic relationship with the host plant and provides nitrogen to cells throughout the plant, both above and below ground, all season long. The use of fertilizers and particularly nitrogen fertilizer is necessary for crop yield and quality. Soybeans and other legume crops have a natural ability to fix nitrogen through their root system, a process supported by rhizobia, which allows inoculated plants to create nodules that fix additional nitrogen in the soil. This practice is commonplace in soybean, but until now there has not been a similar solution for non-legume crops – now there is.

Results: Table 1. illustrates yield gains of +6 and +8 Bu/A. when Envita® was applied in-furrow when nitrogen rate was reduced by 10%, yield increased by +\$16.91 and +\$27.53 A.

This trial was done as a PTI partner trial, implemented by Arnold Farms in Hancock and Hardin County, Iowa.



Source™ Foliar V4 Application Study

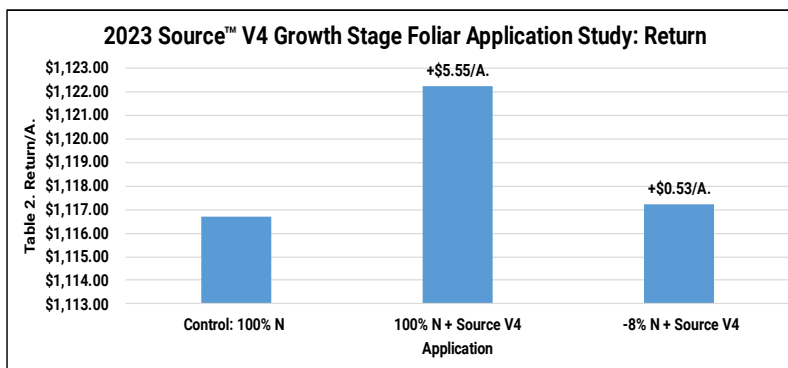
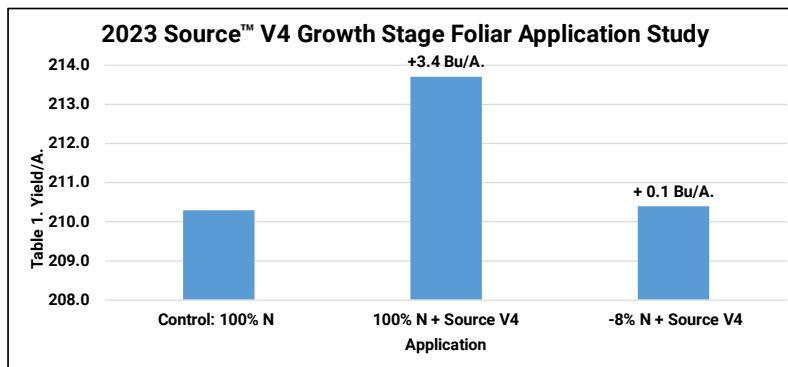
Objective: To evaluate the yield, economics, and nitrogen efficiency of Source™, a foliar-applied nutrient efficiency product that increases plant-available nitrogen and phosphorus to support healthier plants and improved productivity. Source™ contains 20.5% Maltol Lactone that activates nitrogen fixing bacteria, which turns atmospheric nitrogen into a plant available form.



Source™ is applied at a rate of 0.7 fl oz/A. at the V4 growth stage with 20 Gal/A. water carrier.

Due to its potential nitrogen efficiency, Source™ was applied in conjunction with 100% rates of N (180# N) as well as a -8% reduction.

Results: Tables 1-2. illustrate applications of Source™ at V4 resulted in +3.4 Bu/A. yield gains with a positive return on investment of +\$5.55/A. when applied with normal 100% nitrogen rates. As nitrogen rates were decreased by 8% with Source™, yield was stable and +0.1 Bu/A. of the control. Economics in Table 2. illustrate a positive return on investment of +\$0.53/A.



Source™ Foliar VT Application Study

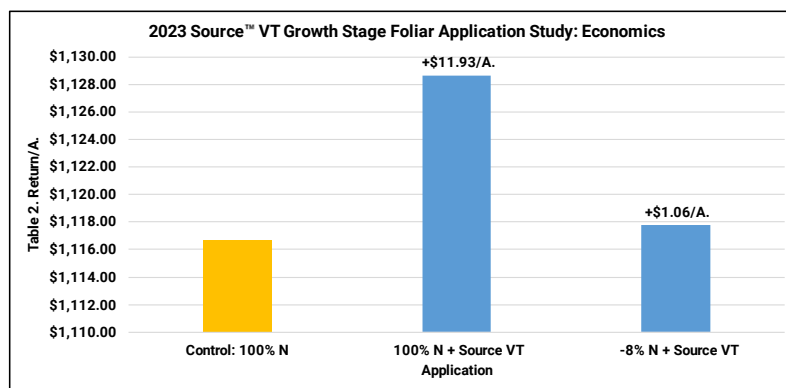
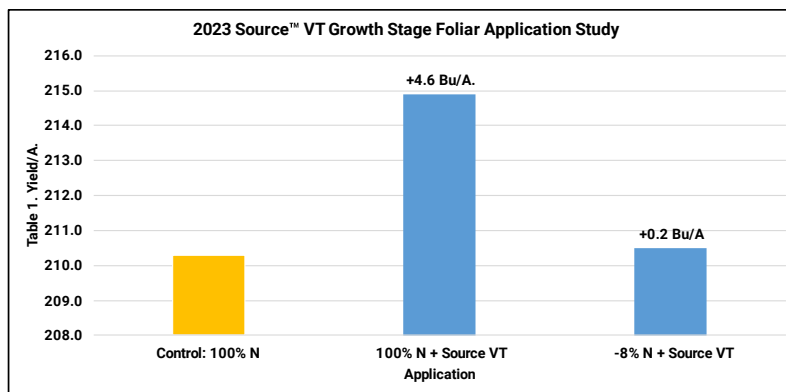
Objective: To evaluate the yield, economics, and nitrogen efficiency of Source™, a foliar-applied nutrient efficiency product that increases plant-available nitrogen and phosphorus to support healthier plants and improved productivity. Source™ contains 20.5% atmospheric nitrogen into a plant available form.



Source™ is applied at a rate of 0.7 fl oz/A. at the VT growth stage with 20 Gal/A. water carrier.

Due to its potential nitrogen efficiency, Source™ was applied in conjunction with 100% rates of N (180# N) as well as a -8% reduction.

Results: Tables 1-2. illustrate applications of Source™ at VT resulted in +4.6 Bu/A. yield gains with a positive return on investment of +\$11.93/A. when applied with normal 100% nitrogen rates. As nitrogen rates were decreased by 8% with Source™, yield only went up by +0.2 Bu/A. of the control with a return of +\$1.06/A.



Planting Date: 4/28 Hybrid: AgriGold® 639-70 Pop: 36K Row Width: 30" Rotation: CAB Corn Price: \$5.31 N Cost: \$0.88/# Source: \$12.50/A.

QLF® L-CBF BOOST™ 4-0-3-2S Nitrogen Inclusion Study

Objective: To evaluate yield, net return, and nitrogen use efficiency (NUE) of QLF™ Agronomy's Liquid Carbon-Based Fertilizer (L-CBF) BOOST 4-0-3-2S added to UAN 32% applied through a Conceal® dual band (Figure 1.) application system.

BOOST is a concentrated source of available carbon in a low pH chemistry package. Derived of a cane molasses-based product (30% sugar) with a fermentation yeast extract, BOOST also contains chemistry designed to stimulate biological activity and enhance nutrient cycling in soils. Since BOOST works symbiotically to directly support the health and productivity of the soil by feeding soil microbes and assisting with nutrient cycling, this study specifically evaluates the ability of BOOST to act as nitrogen inclusion additive to aid in NUE.

For this study, a 10% and 25% nitrogen inclusion rate of BOOST is evaluated compared to 100% rates of nitrogen (N) without BOOST:

Control: 100% N: 20 Gal Weed-N-Feed, followed by 20 Gal/A. 32% UAN At-Plant Dual Band Conceal® followed by 20 Gal/A. 32% UAN V4 Side-Dress

10%BOOST Inclusion: 6 Gal/A. reduction of 32% UAN and replaced w/BOOST

25%BOOST Inclusion: 15 Gal/A. reduction of 32% UAN and replaced w/BOOST

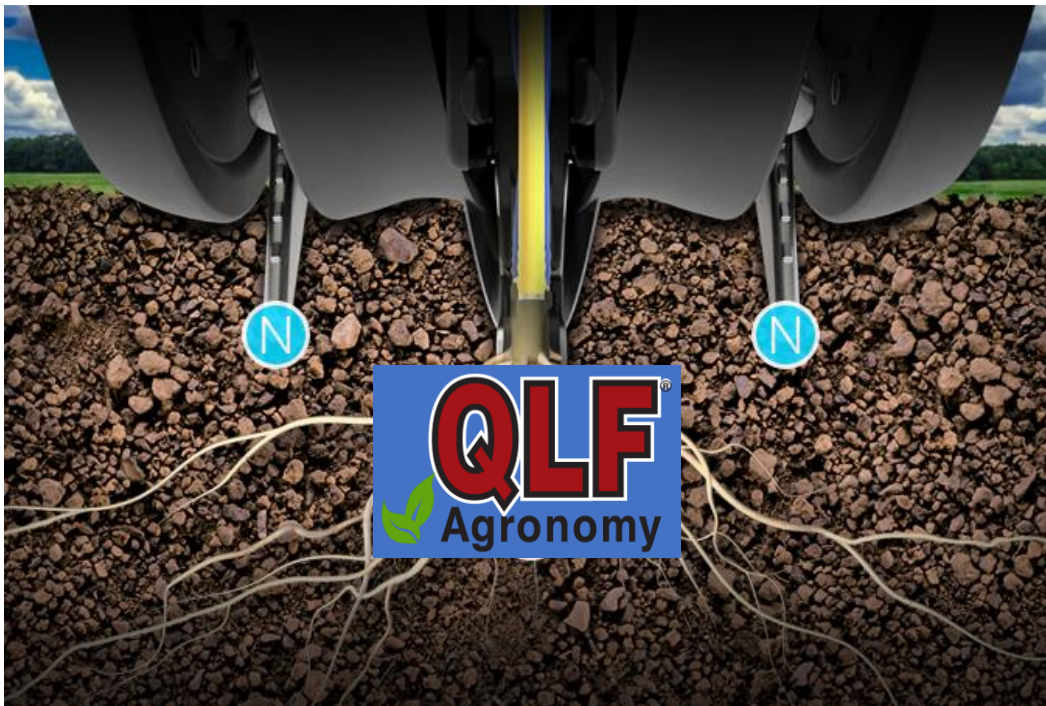
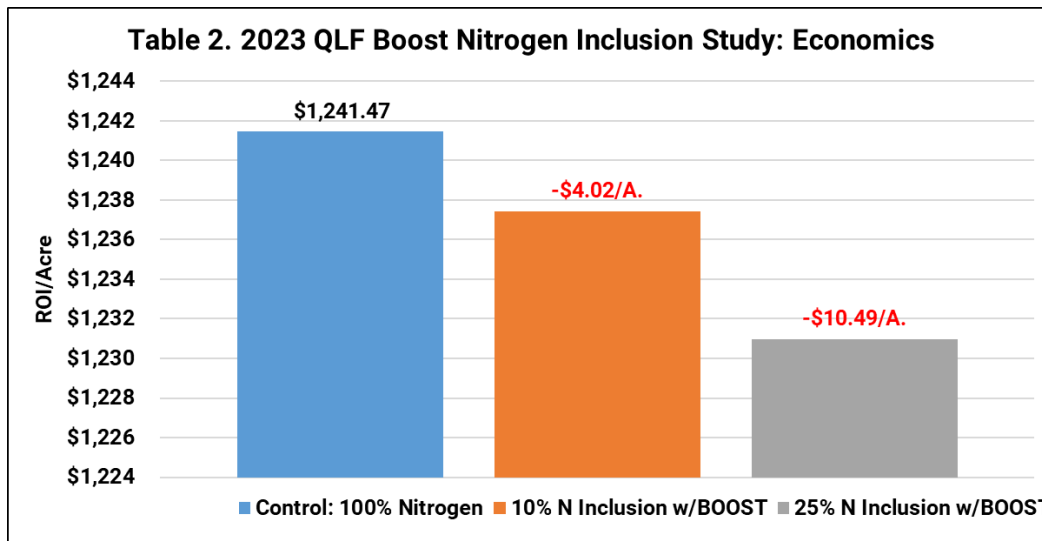
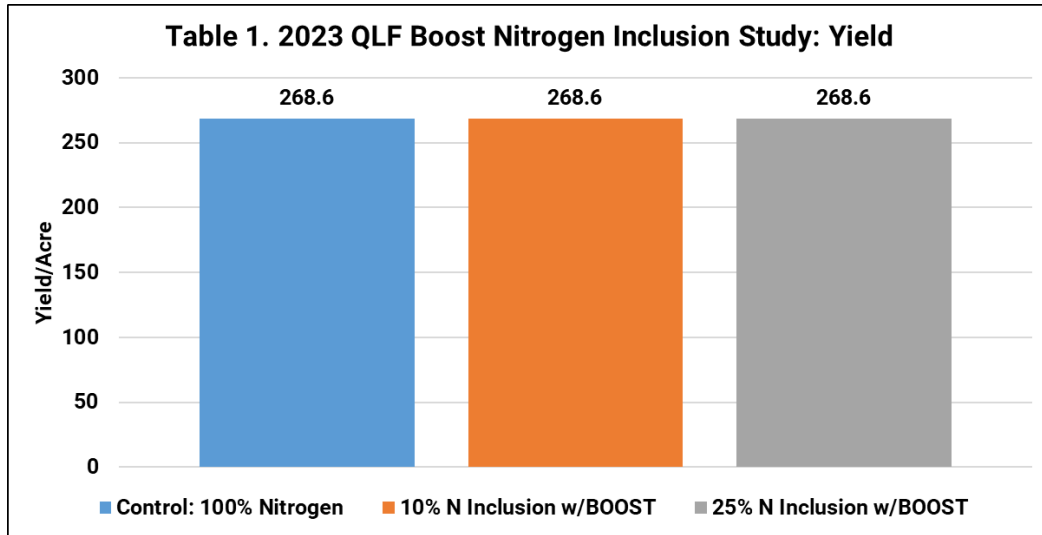


Figure 1. Conceal Dual Band Nitrogen Placement

QLF® L-CBF BOOST™ 4-0-3-2S Nitrogen Inclusion Study Con't

Results: Tables 1-2. illustrate no yield differences between all three nitrogen programs. All treatments yielded 268.6 Bu/A. However, Table 2. depicts the real story, as both inclusion rates realize economic losses of **-\$4.02** and **-\$10.49/A.** respectively.

This 2nd year study reflects efficiencies gained with the BOOST inclusion, ensuring a better recovery of UAN 32% investment delivered through the Conceal® dual band system.



Aqua-Yield® NanoCS™ FurrowJet® Study

Objective: To evaluate yield and economics of NanoCS® by AQUA-YIELD. NanoCS® is a starter fertilizer enhancer with a robust combination of NanoShield® Technology, balanced NPK, Zinc, and Bio Stimulant. Aqua-Yield products contain nanoparticles that penetrate cell walls and creates a nano-sized shield around nutrient/molecules/ions. This technology delivers essential nutrients into the seed for rapid germination and growth.

This trial aims to establish the efficiency of Aqua-Yield's NanoCS® nano-liquid based fertility product in tandem with Marco QuickGrow LTE (6-20-4-2.75S-2.75Zn) in-furrow starter fertilizer. Performance of a 50% rate reduction (4Gal/A.) of LTE is then compared to the 100% rate (8 Gal/A). NanoCS® was applied in-furrow at planting in a FurrowJet® center only application (Figure 1).

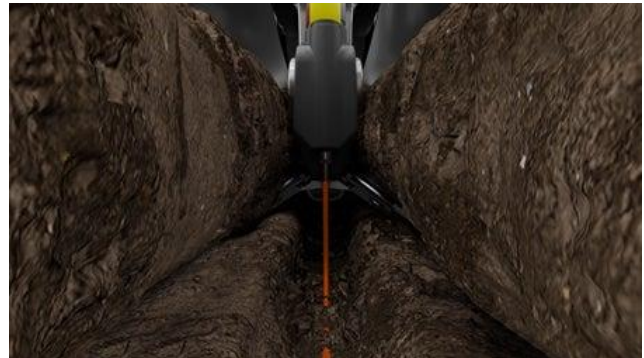
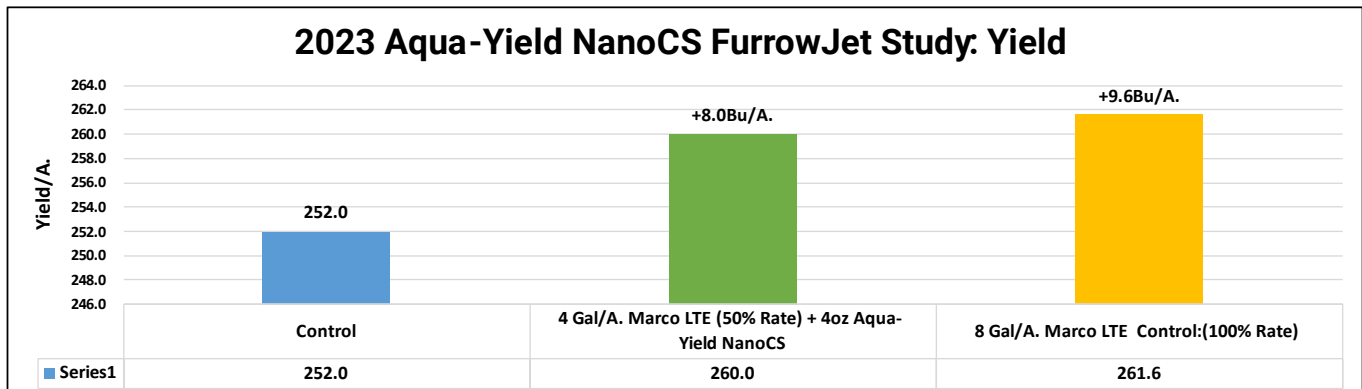


Figure 1: FurrowJet® In-Furrow Application



AQUA-YIELD®

NanoCS™

Aqua-Yield® NanoCS™ FurrowJet® Study Continued

Results: Table 1. illustrates yield results of all treatments. The control treatment brought yields of 252.0Bu/A. The 100% rate treatment at 8 Gal/A. of LTE resulted in yields of +9.6Bu/A.

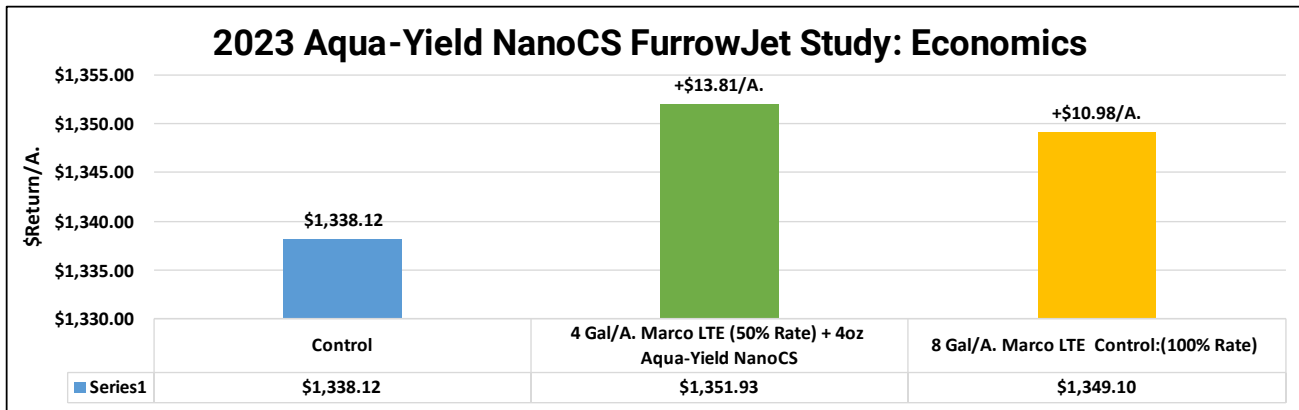
Aqua-Yield's NanoCS® tank-mixed with 50%(4Gal) LTE rates resulted in +8.0 Bu/A. yield improvement over the control treatment.



Table 2. illustrates the overall economics of the fertility study. Reducing LTE in-furrow applications by 50% and tank-mixing NanoCS® resulted in economic gains of +\$13.81/A.

2023 was the PTI Farm's 3rd year testing NanoCS®. In 2021, NanoCS® resulted in +0.3 Bu/A. yield gains with corresponding net revenue gains of +\$6.87/A. when used in conjunction with a 10-18-4 in-furrow starter fertilizer. In 2022, NanoCS® resulted in +3.3 Bu/A. yield gains with corresponding net revenue gains of +\$29.20/A. when used in conjunction with a 10-18-4 in-furrow starter fertilizer.

As farmers, we are always interested in the ability to reduce fertilizer rates without sacrificing yield or profitability and we look forward to testing this product for a fourth year in 2024.



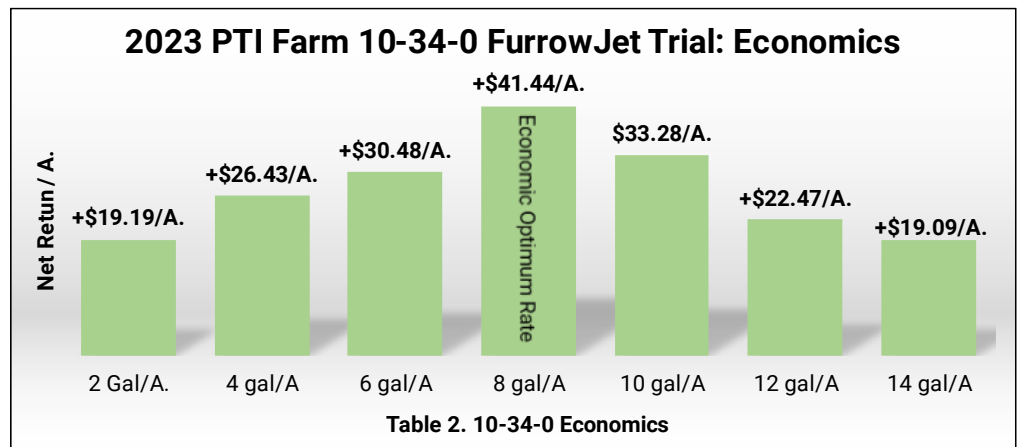
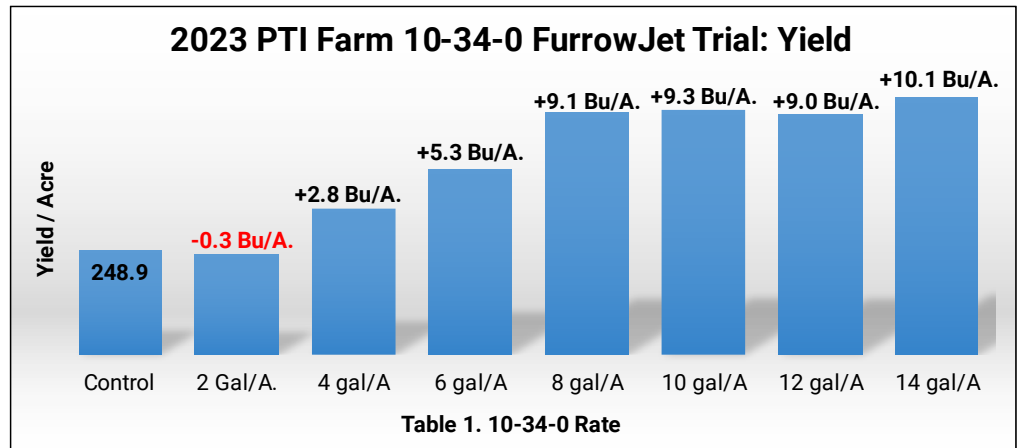
10-34-0 FurrowJet® Study

Objective: To evaluate the yield and net return of 10-34-0 liquid starter fertilizer. Seven different rates were used in a tri-band FurrowJet® system application at planting. 10-34-0 is a 70% polyphosphate formulation of nitrogen and phosphorus.

Results: 14 Gal/A. rates of 10-34-0 resulted in agronomic optimum rate, however economic optimum rate occurred at 8 Gal/A. with yield gains of +9.1 Bu/A. resulting in positive net returns of +\$41.44/A. As rates of 10-34-0 exceeded 8 Gal/A., yields were stagnant.

It is interesting to note that only three 10-34-0 rates (6, 8 and 10 Gal/A.) achieved a return on investment of \$30 or more. For this study, we utilized a \$30 re-allocation program, where we reduce our fall dry fertilizer by \$30 to allow for the fertilizer being applied in the spring on the planter (in this case 10-34-0). If a re-allocation program was not implemented, 10-34-0 treatments with gains under \$30/A. would have resulted in net economic losses.

Figure 1: FurrowJet® 3-Way In-Furrow Band



Ethos® XB FurrowJet® Study

Objective: This FurrowJet® system (Figure 2.) trial evaluates the yield and net return of Ethos XB, an insecticide/fungicide that combines the active ingredient of Capture® LFR® insecticide with a broad-spectrum bio-fungicide. This combination defends against insect pest such as corn rootworms, wireworms, grubs, seed corn maggots, cutworms, and common stalk borers. This also defends against diseases such as Fusarium, Pythium, Rhizoctonia and Phytophthora.

The bio-fungicide in Ethos XB insecticide/fungicide forms a protective barrier on root surfaces and builds over time as spores germinate and colonize roots and root hairs.

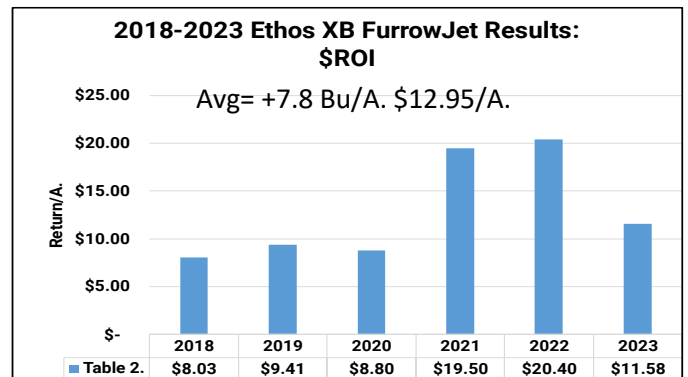
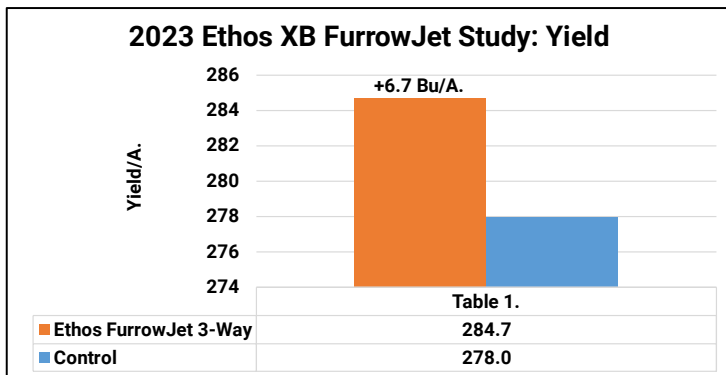
Results: Ethos XB treatments applied through FurrowJet® system offered positive yield gains of +6.7 Bu/A. (Table 1.) Six years of testing (2018-2023) has realized average yield gains of +7.8 Bu/A. along with an average return on investment of +\$12.95/A. (Table 2.)

Figure 1.

ACTIVE INGREDIENTS:	By Wt.
Bifenthrin *	15.67%
<i>Bacillus amyloliquefaciens</i> strain D747 **	5.00%
Other Ingredients	79.33%
Total:	100.00%

*Cis isomers 97% minimum, trans isomers 3% maximum
 ** Contains a minimum of 1x 10¹⁰ colony-forming units (cfu) per milliliter of product.
 This product contains 1.5 lbs bifenthrin per gallon.

Figure 2.



Planting Date: May 5th Hybrid: GH 14B32 Population: 36K Row Width: 30" Rotation: CAB Corn Price: \$5.31 Ethos XB: \$24/A. Rate: 8.5 oz/A

Xyway® LFR® FurrowJet® Study

Objective: To evaluate the yield and economic return of Xyway® LFR®, a fungicide with the active ingredient Flutriafol (Figure 1). Xyway® LFR® fungicide is promoted as a revolutionary at-plant fungicide formulation that provides season-long disease protection from the inside out, root, stalk, and leaf.



Figure 1.

EPA Reg. No. 279-9638	EPA Est. No. 279-DE-001
Active Ingredient:	By Wt.
Flutriafol	26.4%
Other Ingredients:	73.6%
TOTAL:	100.0%

Contains 2.5 pounds per gallon of the active ingredient flutriafol. Suspension Concentrate.

This study evaluates Xyway® LFR® applied in various soil applied situations. First, Xyway® LFR® is evaluated as a in-furrow treatment applied through FurrowJet®, a planter fertilizer attachment that enables placement of fertilizer on the seed as well as 3/4" on each side of the seed (Figure 2). To achieve this dual-band placement, the wings on FurrowJet® system angle downward to cut into the sidewall and place fertilizer alongside the seed in a dual-band. By doing this, lifting and fracturing can occur that potentially could remove soil smearing or compaction created by disc openers. In this study, Xyway® LFR® is evaluated in FurrowJet® Wing placement only.



Figure 2. FurrowJet® In-Furrow Planter Attachment

Secondly, to focus on applications of Xyway® LFR® further away from the seed, a second treatment was also evaluated with Conceal®. A Conceal® system is a unique planter attachment that allows growers to place product in a high concentration dual or single band positioned 3" away from the seed trench (Figure 3.) in depths near 1.5". The Conceal® system uses existing planter space, utilizing a backswept knife located with-in the center of the planter's gauge wheels. As product is applied, it is sealed within the soil profile by the gauge wheels.



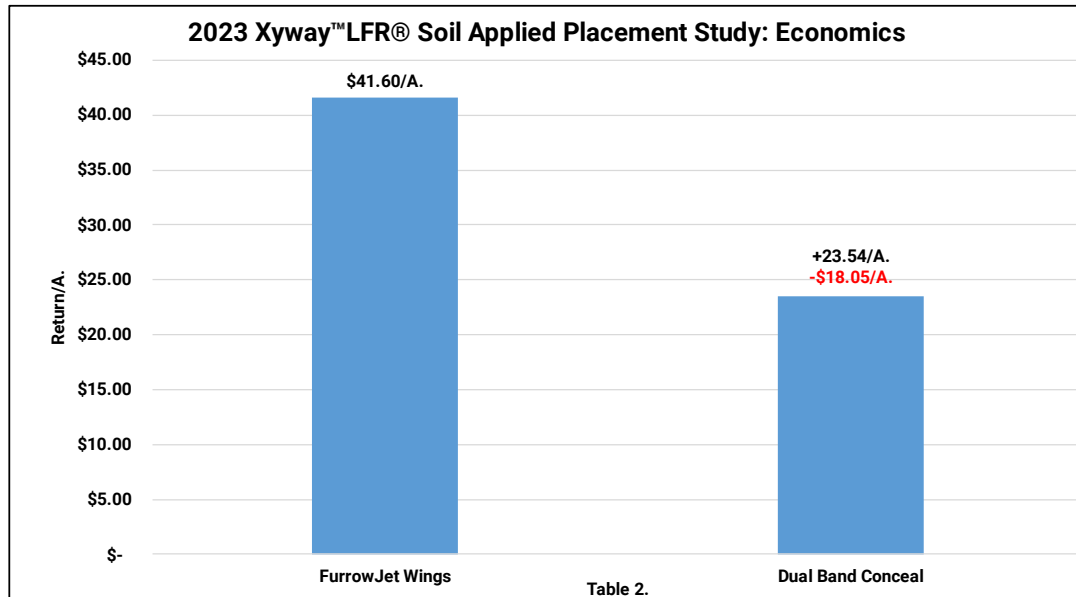
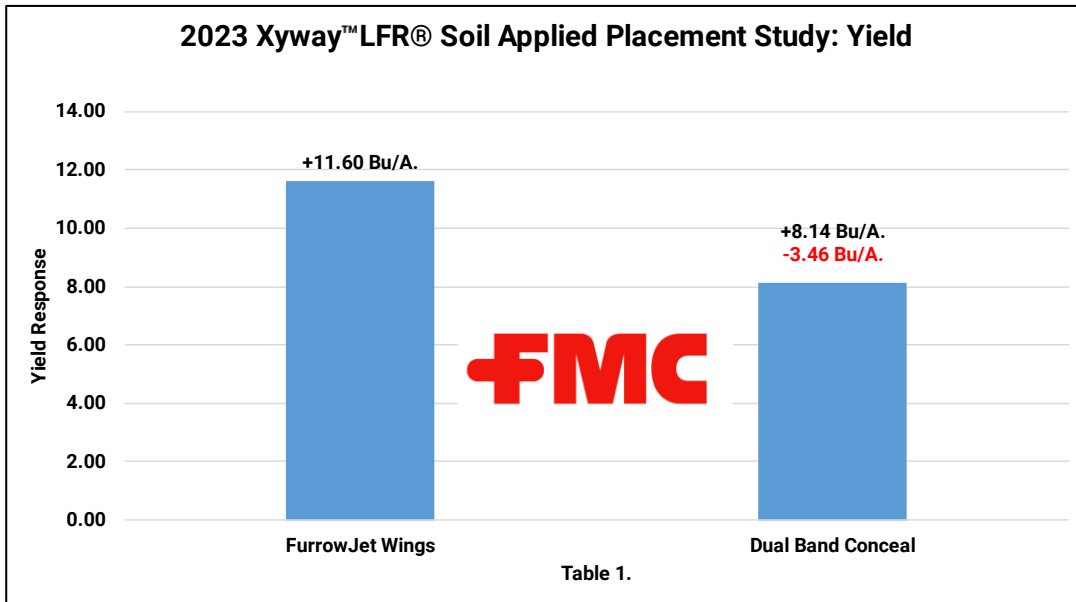
Figure 3. Conceal Dual Placement 3" from Seed Trench



Xyway® LFR® FurrowJet® Study Continued

Results: Both placements offered positive yield and economic return. FurrowJet treatments tallied +11.6 Bu/A. gains with net returns of +\$41.60/A. Conceal treatments offered +8.14 Bu/A. gains with net returns of +\$23.54/A.

However, flutriafol placed in furrow with FurrowJet® wings offered a +3.46 Bu/A. yield gain over Conceal dual band treatments. This difference in placement resulted in FurrowJet® gains of +\$18.05/A.



Planting Date: May 15th Hybrid: GH 14B32 Population: 36K Row Width: 30" Rotation: CAB Corn Price: \$5.31 XYWAY LFR: \$20/A.

FurrowJet® Side-Wall Study

Objective: FurrowJet® is a planter fertilizer attachment (Figure 1.) that enables placement of not only an in-furrow starter fertilizer, but also a dual-band of fertilizer 3/4" on each side of the seed (Figure 2). To achieve this dual-band placement, the wings on FurrowJet® system angle downward to cut into the sidewall and place fertilizer alongside the seed in a dual-band. By doing this, lifting and fracturing can occur that potentially could remove soil smearing or compaction created by disc openers. (Figure 3.) Additionally, closing wheel systems following FurrowJet® wings have a better opportunity to close the seed trench, remove air pockets, and allow for good seed-to-soil contact.

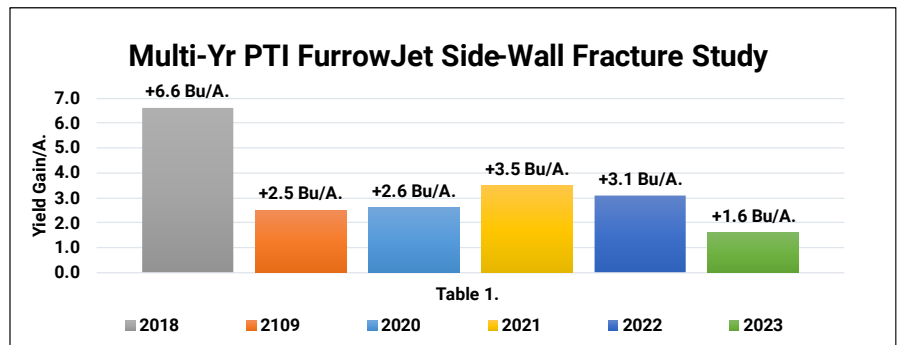
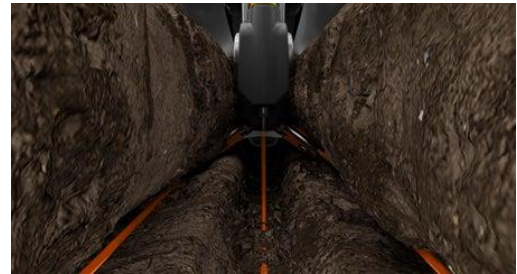
This study evaluates FurrowJet® dual-band wings offering the ability to cut, lift and remove side-wall compaction in the seed furrow. For this study, no liquid fertilizer was applied.

Results: Table 1. illustrates the side-wall fracture advantages of FurrowJet® system in the 2018 to 2023 growing seasons. While 2018 offered +6.6 Bu/A. advantages, 2019 to 2023 all have proved significantly less at only +2.5, +2.6, +3.5, +3.1 and +1.6 Bu/A. respectively. As mentioned in the objective, FurrowJet® systems do have the ability to assist in closing the furrow due to easier side-wall collapse. In 2019 -2023 our plot planter was fitted with a FurrowForce® system, a robust automatic sensing and control closing wheel system. It is our belief that this system closed the gap on FurrowJet® system advantages due to superior closing activity. For growers using traditional single stage closing systems, FurrowJet® response could be more typical to 2018’s yield response.

Figure 1. FurrowJet®



Figures 2-3: FurrowJet® Wings Fracturing Sidewalls



Corn Summary of 2023 FurrowJet® Applications

PTI Farm Study	Bu/A.	ROI\$/A.
Marco QuickGrow LTE 4 gal	8	\$52.48
Nachurs imPulse 7 gal	8.9	\$47.26
Nachurs imPulse 6 gal	8.6	\$45.67
Envita + 100% N	11.4	\$45.58
Xyway	11.6	\$41.60
10-34-0 8Gal	9.1	\$41.44
Nachurs imPulse 5 gal	7.8	\$41.42
Marco QuickGrow LTE 8 gal	9.6	\$40.98
10-34-0 10Gal	9.3	\$33.28
10-34-0 6Gal	5.3	\$30.48
Envita IA Hardin County	8	\$27.53
10-34-0 4Gal	2.8	\$26.43
10-34-0 12Gal	9	\$22.47
Short Corn Combo over Control	12.9	\$22.36
10-34-0 2Gal	-0.3	\$19.90
10-34-0 14Gal	10.1	\$19.09
Envita IA Hancock County	6	\$16.91
PhycoTerra 1qt FurrowJet 3-Way	4.7	\$14.96
Marco LTE 4 Gal + NanoCS	8	\$13.81
Ethos XB	6.7	\$11.58
Marco LTE 8 Gal	9.6	\$10.98
FurrowJet Sidewall	1.6	\$8.50
PhycoTerra 1pt Dual Band Conceal + 1pt FurrowJet	3.2	\$6.99
PhycoTerra 1qt Dual Band Conceal + 1qt FurrowJet	4.3	\$2.83
Envita -10% N	0.1	\$1.46
Short Corn In-Furrow Fertility Program	1.9	-\$2.54
Corn Plant Date with Starter - April 13th	9.3	-\$14.46
Corn Plant Date with Starter - April 24th	7.8	-\$22.43
Corn Plant Date with Starter - May 5th	7.7	-\$22.96
PROVEN 40 + 18% Nitrogen Reduction	-7.1	-\$23.66
Corn Plant Date with Starter - May 18	2.1	-\$52.69
Corn Plant Date with Starter - June 7th	-0.6	-\$67.03

Single Application Pre-Emerge N Study: Conceal® vs. Weed-N-Feed 100%

Objective: To compare 100% single applications of surface applied broadcast Weed-N-Feed (WNF) 32% UAN treatments to Conceal® system single and dual band at-plant nitrogen applications. Conceal® system is a unique planter attachment that allows growers to place nitrogen in a high concentration dual or single band positioned 3" away from the seed trench in depths near 1.5" (Figure 2). The Conceal® system uses existing planter space, utilizing a backswept knife located with-in the center of the planter's gauge wheels (Figure 1). As nitrogen is applied, it is sealed within the soil profile by the gauge wheels, preventing potential volatilization losses that is typically problematic with surface type nitrogen applications.

Results: Table 1. illustrates that

Conceal® system dual band applications of nitrogen out-yielded traditional 100% WNF by +5.6 Bu/A., while Conceal® system single band treatments out-performed the same by +11.1 Bu/A.

2023 planter applied nitrogen equated to additional revenue gains over WNF applications by +\$29.74/A. and +\$58.94/A.

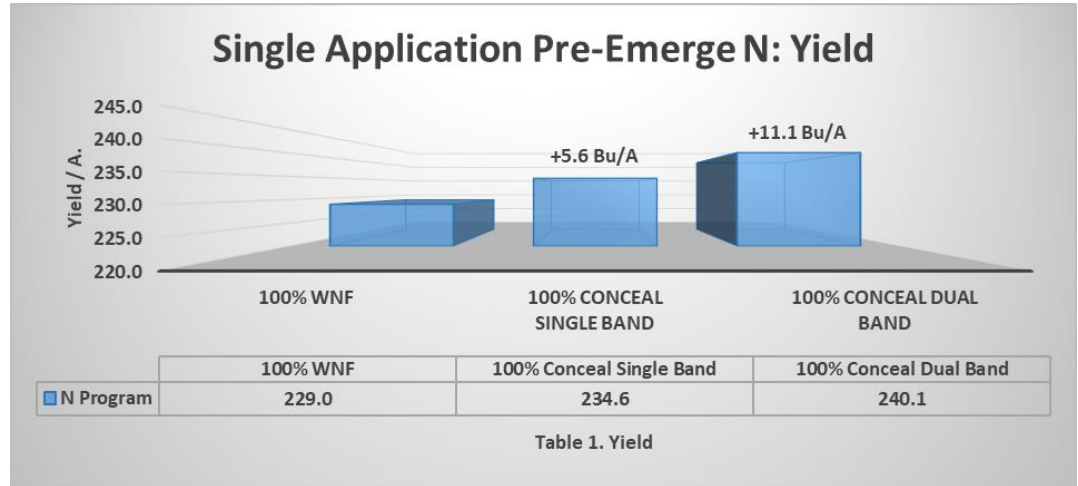


Figure 1. Conceal System Knife Design within Gauge Wheel



Figure 2. Conceal Dual Placement 3" from Seed Trench



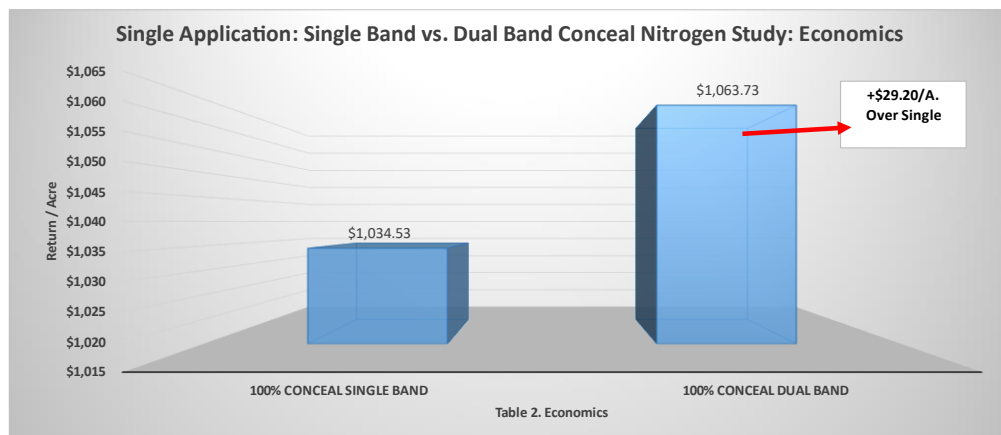
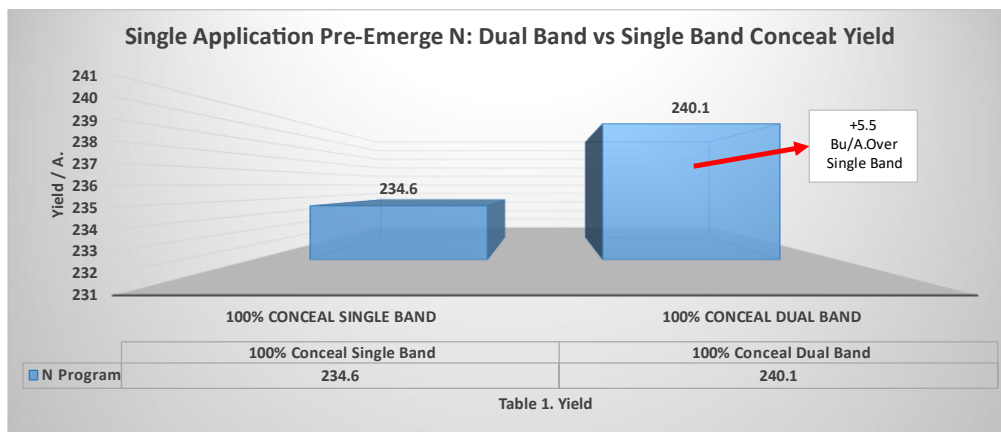
Single Band vs. Dual Band Conceal® Nitrogen Study

Objective: To compare dual band versus single band applications of nitrogen in an at-plant scenario using Conceal®. Both treatments consist of 100% of 180lbs total nitrogen at planting, all using UAN 32%.

A Conceal® system is a unique planter attachment that allows growers to place nitrogen in a high concentration dual or single band positioned 3” away from the seed trench (Figure 1.) in depths near 1.5”. If corn is planted at a 2” depth, Conceal® system fertilizer placement is 3X-0.5X1 in single bands and 3X-0.5X2 in dual bands.

Conceal® uses existing planter space, utilizing a backswept knife located within the center of the planter’s gauge wheels (Figure 1). As nitrogen is applied, it is sealed within the soil profile, preventing potential volatilization losses typically seen with surface type nitrogen applications.

Results: Table 1. illustrates that dual band applications of nitrogen out-yielded single band applications by +5.5 Bu/A. These yield gains consequently equated to additional net returns of +\$29.20/A. (Table 2).



Planting Date: 4/26th Hybrid: Wyffels 7208RIBSS Population: 36K Row Width: 30" Rotation: CAC Corn Price: \$5.31 N Price: \$0.88/#

Multi-Year Nitrogen Rate/Placement Study

Objective: This 7-yr long-term study evaluates the performance of nine different nitrogen rate and placement programs. These nine programs consist of single one and done nitrogen programs, 2-way split applications, and even 3-way split programs. All treatments are applied using 32% UAN liquid nitrogen. As a baseline, the 50% WNF + 50% V6 Side-Dress (Treatment #4) is facilitated as the control for this trial.

1. 100% Weed-N-Feed (WNF):	240# N as Surface applied 32% UAN	Single Applications
2. 100% Conceal® Single Band:	240# N with Conceal® Single N Band 1.5" Deep	
3. 100% Conceal® Dual Band:	240# N with Conceal® Dual N Bands 1.5" Deep	
<hr/>		
4. 50% WNF+50% Side-Dress (SD):	120# N WNF+ 120# N V6 side-dress: "Control"	Dual Split Applications
5. 50% Conceal® Single Band+50% SD:	120# N Conceal® Dual Bands + 120# N V6 SD	
6. 50% Conceal® Dual Band+50% SD:	120# N Conceal® Dual Bands + 120# N V6 SD	
7. 25% Conceal® Dual Band+50% SD:	60# N Conceal® Dual Bands + 120# V6 SD	
8. 75% Conceal® Dual Band+50% SD:	180# N Conceal® Dual Bands + 120# N V6 SD	Triple Split Applications
9. 25% Conceal®+25%WNF+50% SD:	90# N WNF + 90# N Conceal® Dual Bands + 120# SD	

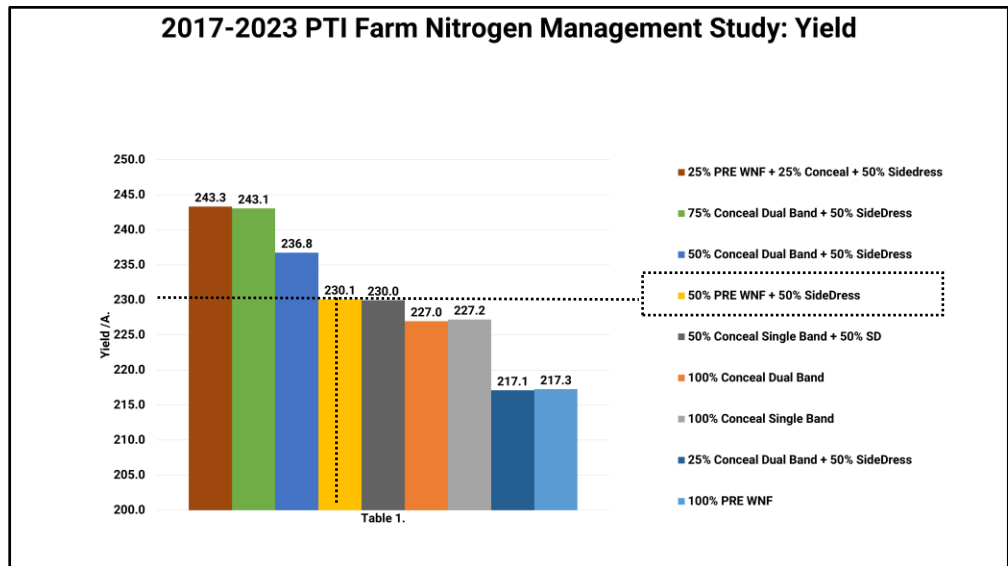
Results: Table 1. illustrates yield results of all nine nitrogen programs. All three of the single nitrogen applications (Treatments 1-3), along with the -25% reduced rate treatment, have proven the lowest performances over the time frame of this study.

The Triple Split nitrogen rate treatment (25%WNF + 50% Conceal® Dual Band+50 SD) has offered the overall highest yields at 243.3 Bu/A. over the 7-years.

Dual nitrogen programs (Programs 4-8) have out-yielded single N programs (1-3) by +7.59 Bu/A.

The triple N program (Program 9) have out-yielded single nitrogen programs by +19.5 Bu/A. and offered increased yield over dual programs by +11.8 Bu/A.

The top three programs offered yield gains of +6.7 to +13.2 Bu/A. over the control, the 50% WNF + 50% Sidedress.



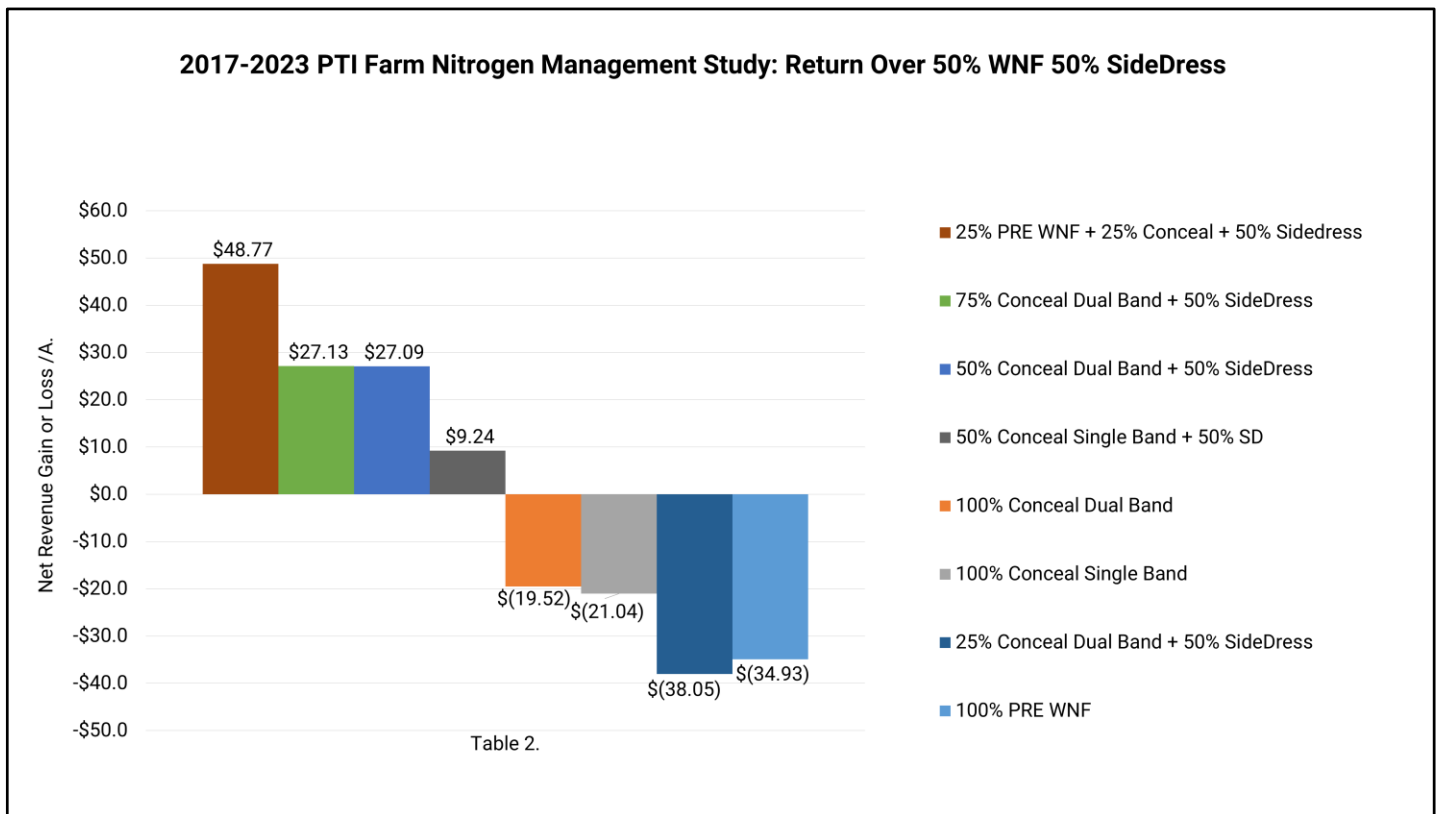
Multi-Year Nitrogen Rate/Placement Study

Table 2. continues the story by calculating net return after cost of nitrogen. The top nitrogen program over the 7-yr period the triple split program (Treatment #9) and has resulted in positive economic returns of +\$48.77/A., compared to the 50% WNF + 50% side-dress control (Program #4). This top performer was also offered a +83.7 Bu/A. increase over the lowest return application, a one and done 100% Weed-N-Feed program.

To help understand the efficiency of the applications, we evaluated adjusting nitrogen rate by +25% and -25%. Adding 25% more nitrogen was the 2nd overall highest yielding treatment, but also resulted in the 2nd highest overall net return after the cost of N, albeit **-\$21.64/A.** less than the top triple split program.

Lowering nitrogen rate by 25% has turned our costly, as yields have suffered **-13.0 Bu/A.** along with decreased returns of **-\$38.05/A.** compared to the control. However, please note this -25% reduced rate of N, still offered +\$3.57/A. above the single application 100% WNF rate of N.

Single application nitrogen programs posted negative economic returns of **-\$19.52, -\$21.04** and **-\$34.93.A**



Multi-Year Nitrogen Rate/Placement Study

Table 3. helps clarify the yield advantages of split applications of nitrogen compared to a one and done 100% WNF application. Adding a dual application side-dress treatment in addition to a WNF program, has offered +12.8 Bu/A. yield advantages.

If we take this one step further, adding a planter applied application (triple split) offered even higher yields at +26.0 Bu/A.

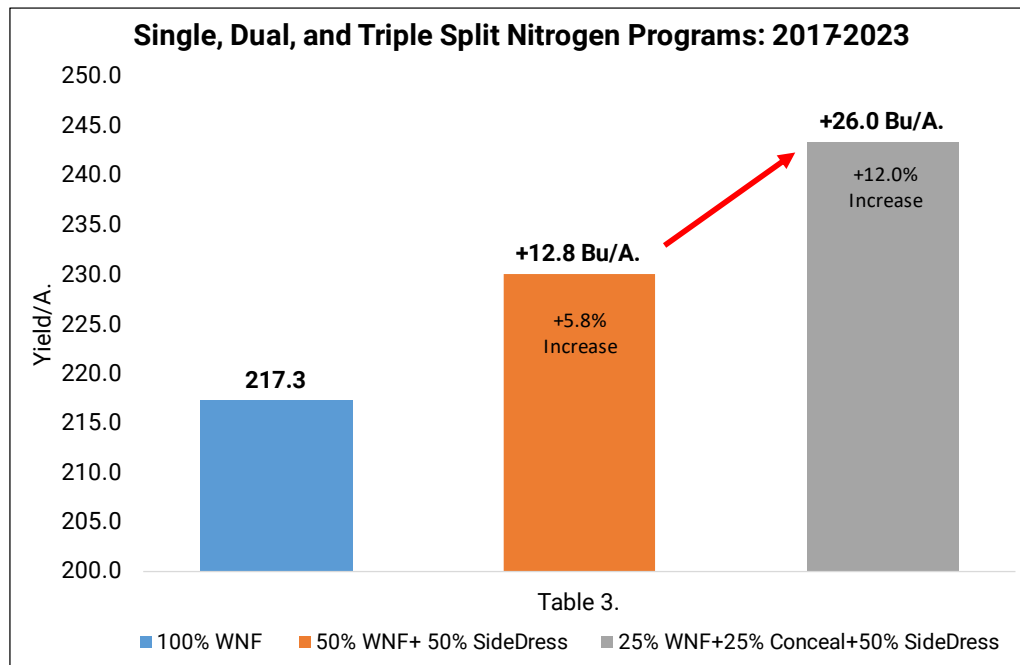


Figure 1. Weed-N-Feed Nitrogen



Figure 2. Conceal At-Plant Nitrogen



Figure 3. Side-Dress Nitrogen



Nitrogen Sealer Study

Objective: To evaluate the yield and economic impact of implementing nitrogen sealers when side-dressing corn with liquid nitrogen (N). Nitrogen sealers from Nitrogen Sealing Systems in Catlin, IL are a pair of coulters that attach to a side dress unit behind the knife or high-pressure injection nozzle (Figure 1-2). Sealers are designed to lift and redirect soil over top of the injection point of nitrogen, collapsing and sealing the trench, protecting nitrogen that could otherwise volatilize.

Volatilization is a form of N loss that occurs when nitrogen is applied on the soil surface without incorporation by tillage or rainfall events. In this event, applied nitrogen converts to ammonia, a gaseous form that can easily escape into the atmosphere. In a side-dress situation, this can occur when nitrogen is applied and not sealed or covered properly. If coulters slots open or become exposed to sunlight, air, wind, and increased temperatures after application, volatilization can occur.

Results: Tables 1-2. illustrate nitrogen sealers offering yield gains of +8.2 Bu/A., while capturing an additional +\$43.54/A. Multi-year data over 2020-2023 have proved +8.4 Bu/A. yield gains that have resulted into economic gains of +\$40.31/A.

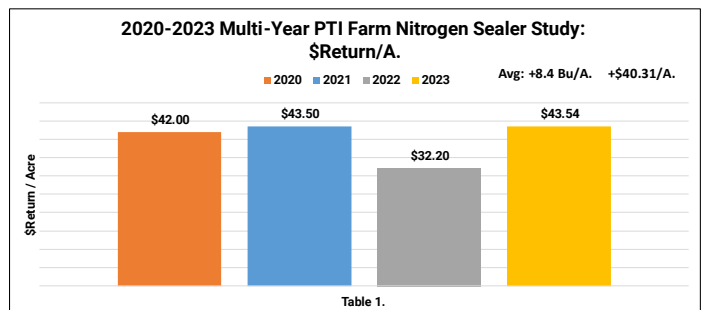
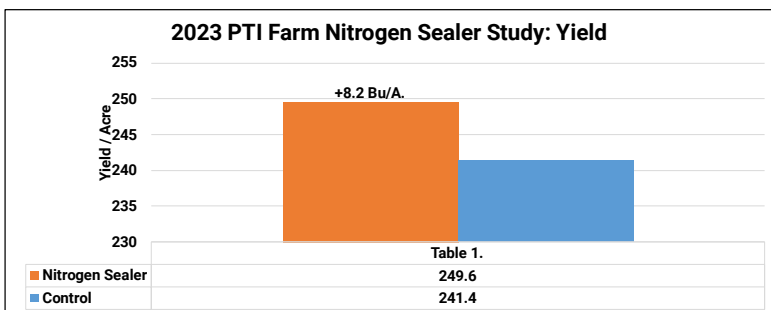
At a cost of \$285/row on a 15-knife side-dress applicator, break-even would occur at 107 acres.



Figure 1. Nitrogen Sealers



Figure 2. Sealed row with soil berm



Planting Date: 5/15 Hybrid: Golden Harvest 15J91 Population: 36K Row Width: 30" Rotation: CAC Corn Price: \$5.31
 Side-Dress Timing: V3 Sealers from Nitrogen Sealing Systems \$285/Row

Conceal® K-Fuse® Potassium Study

Objective: To evaluate the yield and economics of NACHURS® K-Fuse® powered by Bio-K® (Figure 1.), a 6-0-12-12S potassium/sulfur product designed to be blended with UAN fertilizer and applied on the planter or at side-dress. For this study we applied three, five, and eight gallons of K-Fuse® at planting in a dual band Conceal® system application tank-mixed with 27 Gal/A. of UAN 32%. (Figure 2).

Results: In 2023, K-Fuse® applications reached agronomic optimum yield at the highest 8 Gal/A. Yield response ranged from +6 Bu/A. to +10.4 Bu/A. As for economics, Table 2. reveals 3 Gal/A. of K-Fuse® provided economic optimum rate with a positive return on investment of +\$12.06.

Table 3. reveals multi-year data from 2021-2023 where 5 Gal/A of K-Fuse® has proved economic optimum rate with a positive return on investment of +\$23.06/A. over the 3 year period.

Figure 1. Nachurs K-Fuse® Potassium Additive

NUTRIENTS SUPPLIED (pounds per gallon):

Total Nitrogen (N)	0.65
Soluble Potash (K ₂ O)	1.30
Sulfur (S)	1.30

Derived from: Potassium Acetate, Ammonium Thiosulfate, and Urea.

PRODUCT PROPERTIES:

Analysis:	6-0-12-12S
Weight:	10.8 lbs. per gallon
Specific gravity:	1.30 kg/L
pH:	7.4-7.9
Appearance:	Clear, nearly colorless
Odor:	Ammonia odor

GENERAL PRODUCT INFORMATION:

NACHURS K-Fuse is designed to be blended with various other fertilizers to provide important nutrients needed to grow high-yielding crops. Primarily, NACHURS K-Fuses should be blended with UAN solutions for sidedress and/or fertigation application to provide two very critical elements - Potassium and Sulfur. It can also be mixed with APP and UAN for 2x2 and/or strip-till application to provide a more balanced nutrient program. NACHURS K-Fuse contains a proprietary additive which allows for more narrow mixing ratios with UAN solutions than other potassium products currently on the market. Always follow mixing recommendations so as to limit risk potential of forming low solubility potassium nitrate compounds. NACHURS K-Fuse should not come in close proximity to the seed under any circumstance (i.e. in-furrow placement).

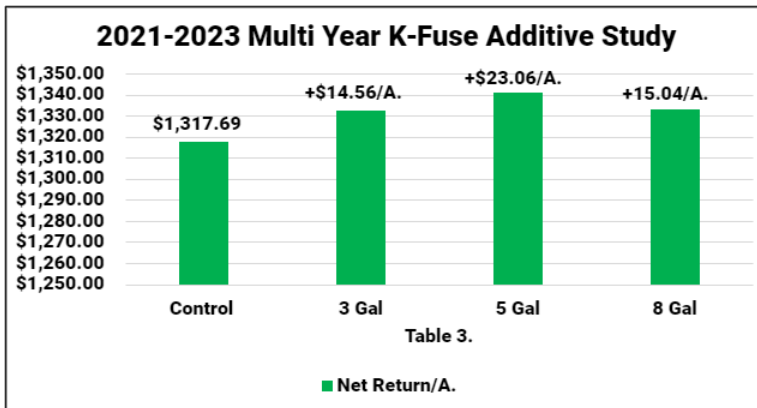
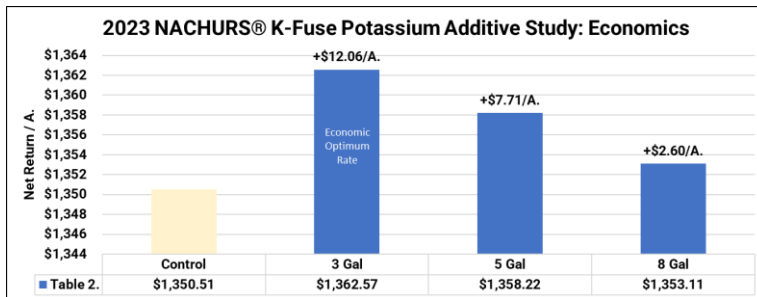
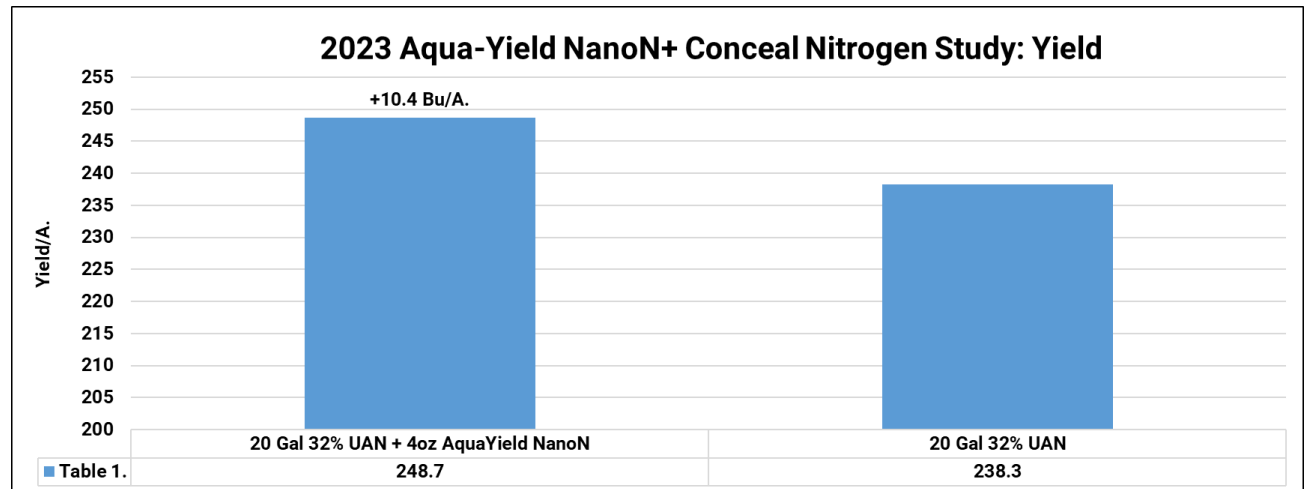


Figure 2. Conceal Dual Placement 3" from Seed Furrow, 1.5" in Depth

Aqua-Yield® NanoN+™ Conceal® Nitrogen Study

Objective: To evaluate yield and economics of NanoN+™ by AQUA-YIELD. NanoN+™ uses AquaYield nanoliquid technology to improve nitrogen use efficiency. NanoN+™ can be added to most liquid fertilizer blends containing nitrogen to enhance uptake. Nanoliquid products effectively work as a deliver system for nutrients and protects molecules from environmental losses and delivers them them to plants at the cellular level. A process called endocytosis brings the nanoliquid particles into the cell where the payload is delivered. This trial aims to establish the efficiency of Aqua-Yield’s NanoN+™ nano-liquid based fertility product in tandem with 32% UAN nitrogen fertilizer. NanoN+™ was applied at planting in a dual band Conceal® application (Figure 1).

Figure 1. Conceal® Placement



AQUA-YIELD®

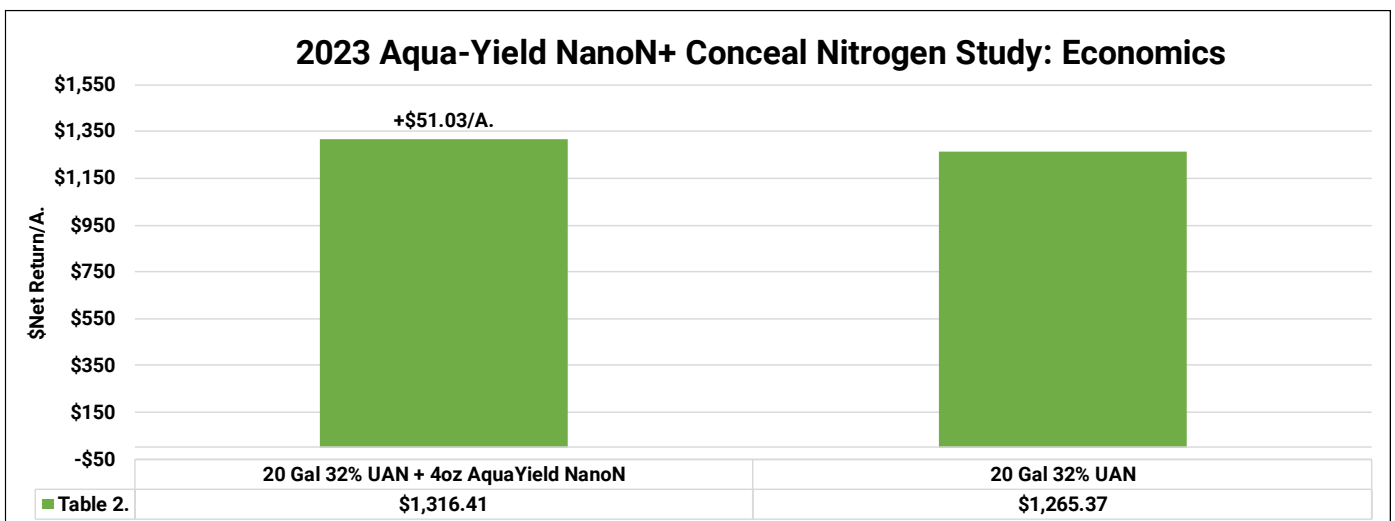
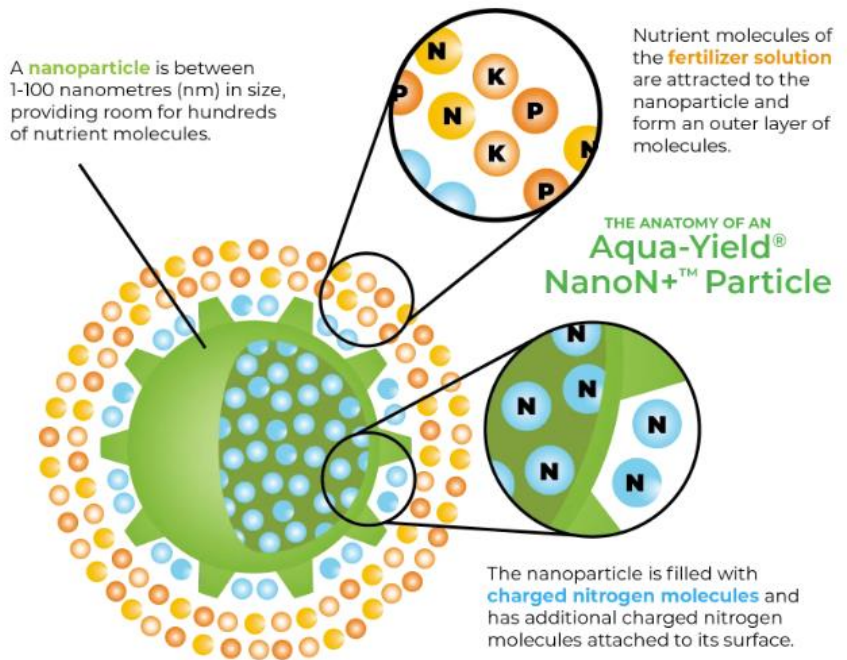
NanoN+™

Aqua-Yield® NanoN+™ Conceal® Nitrogen Study Continued

Results: Table 1. illustrates yield results of all treatments. Aqua-Yield's NanoN+™ tank-mixed with 20 Gal/A. of 32% UAN resulted in +10.4 Bu/A. yield improvement over the control.

Table 2. illustrates the overall economics of the fertility study where NanoN+™ resulted in positive economic gains of +\$51.03/A.

2022-2023 multi-year data has averaged +6.6 Bu/A. with economic returns of +\$31.11/A.

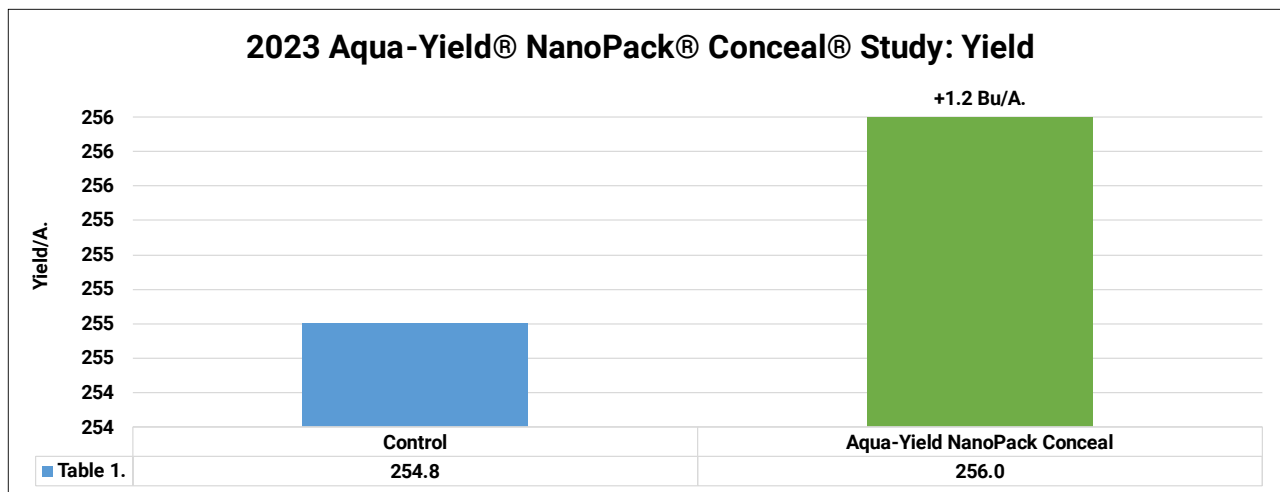


Planting Date: April 28th Hybrid: GH 15J91 Population: 36K Row Width: 30" Rotation: CAC Corn Price: \$5.31 NanoN+®: \$4.19/A.

Aqua-Yield® NanoPack® Conceal® Nitrogen Study

Objective: To evaluate yield and economics of NanoPack® by AQUA-YIELD. NanoPack® (0.5Cu-2Fe-1Mn-1Zn) is a micronutrient product that enhances crop yields and promotes plant health by delivering essential nutrients directly to the cellular level. NanoPack® delivers sulfur, copper, iron, manganese, and zinc through Aqua-Yield® nanoliquid technology. It brings critical micronutrients to plants when soil levels are low and prevents deficiencies that limit crop yield while boosting plant metabolism and overall health. Nanoliquid products effectively work as a deliver system for nutrients and protects molecules from environmental losses and delivers them to plants at the cellular level. A process called endocytosis brings the nanoliquid particles into the cell where the payload is delivered. This trial aims to establish the efficiency of Aqua-Yield’s NanoPack® nano-liquid based fertility product in tandem with 32% UAN nitrogen fertilizer. NanoPack® was applied at planting in a dual band Conceal® application.

Figure 1. Conceal® Placement



AQUA-YIELD®

NanoPack®

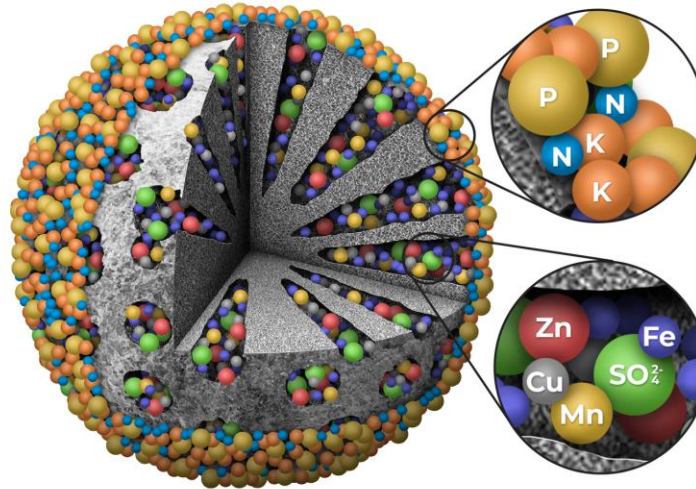
Aqua-Yield® NanoPack® Conceal® Nitrogen Study Continued

Results: Table 1. illustrates yield results of all treatments. Aqua-Yield's NanoPack® tank-mixed with 20 Gal/A. of 32% UAN resulted in +1.2 Bu/A. yield improvement over the control.

Table 2. illustrates the overall economics of the fertility study where NanoPack® resulted in economic losses of **-\$0.97/A.** due to price of the product.

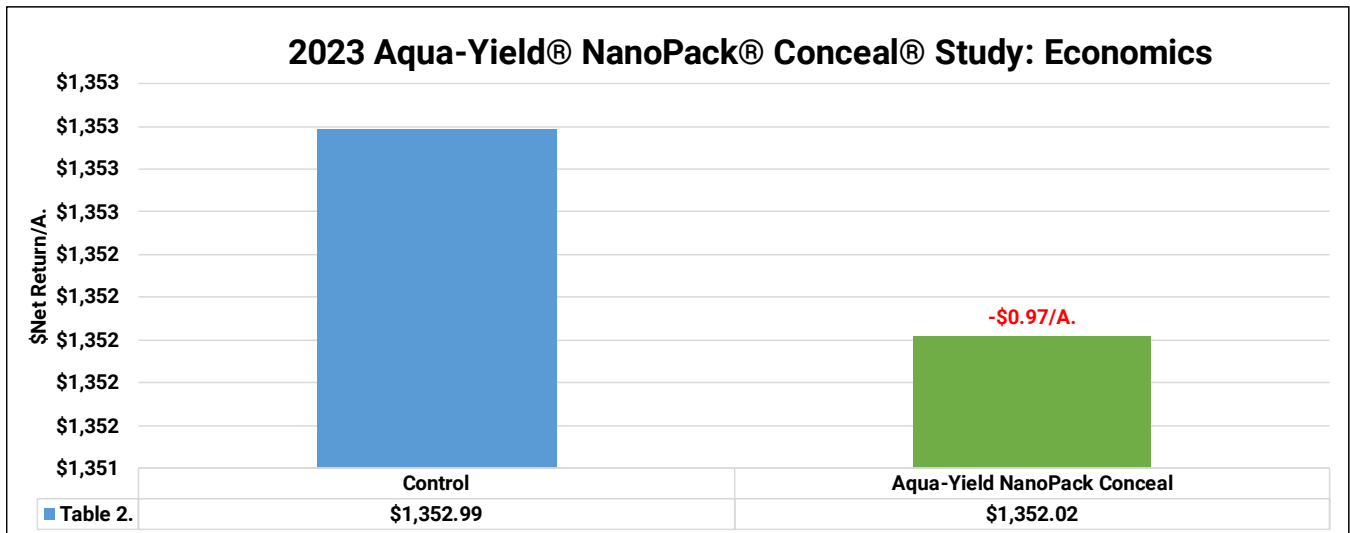
THE ANATOMY OF AN Aqua-Yield® NanoPack® Particle

A **nanoparticle** is between 1-100 nanometers (nm) in size, providing room for thousands of nutrient molecules.



Nutrient molecules of the **fertilizer solution** are attracted to the nanoparticle and form an outer layer of molecules.

The nanoparticle is filled with **charged nutrient molecules** and has additional charged molecules attached to its surface.



Planting Date: April 28th Hybrid: GH 15J91 Population: 36K Row Width: 30" Rotation: CAC Corn Price: \$5.31 NanoPack : \$7.34/A.

PhycoTerra® Conceal® FurrowJet® Soil Amendment Study

Objective: To evaluate yield and economics of PhycoTerra®, a liquid microbial food product that delivers a superior, balanced meal to the starving, dormant microbes in soil. PhycoTerra® activates the soil microbiome (up to 33x) by delivering a superior balanced meal to dormant, native microbes. Waking up microbes, both bacteria and fungi, early in the season can help support your crop throughout the growing season. PhycoTerra® delivers a unique mode-of-action to improve soil structure, increase water holding capacity, and optimize nutrient (NPK) availability. Improved soil quality and health supports crops through abiotic stress throughout each crop season. PhycoTerra® was applied at planting in a dual band Conceal® and FurrowJet® in-furrow application (Figures 1-2), as well as in a V5 sidedress.

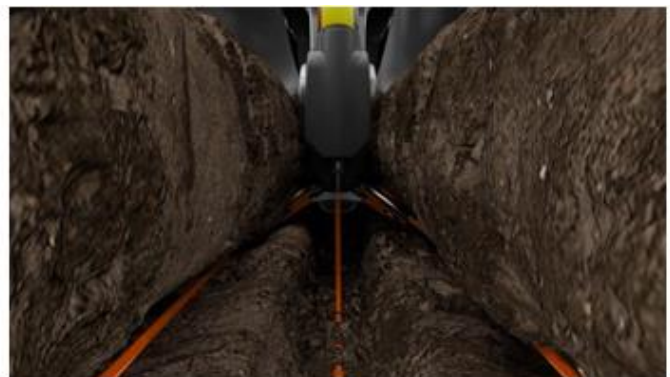


Product Type	g Food/L	g Protein per L	g Lipids per L	g Carb per L	g Ash per L
Molasses Product	74	4	0.8	60	10
Humic Acid Product	7	1	0.12	2	4
Seaweed Product	32	1	0.5	15	15
PhycoTerra®	92	24	21	44	3

Figure 1. Conceal® Placement

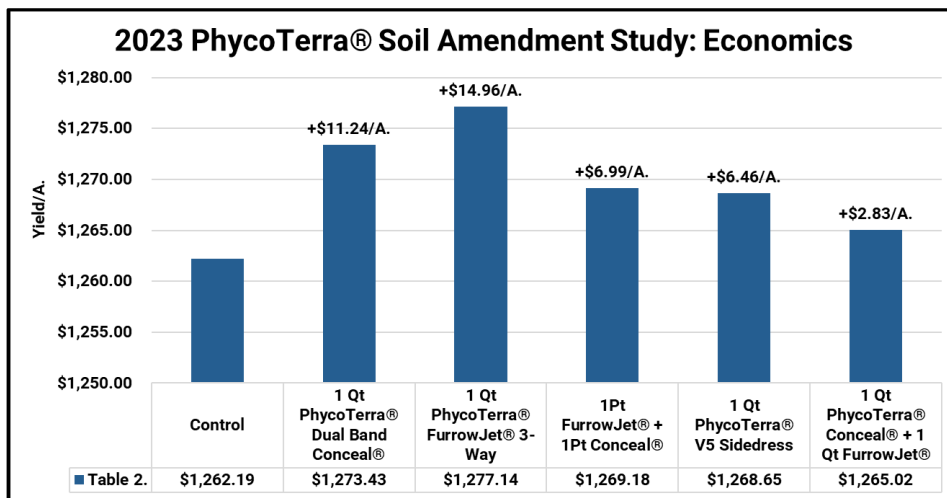
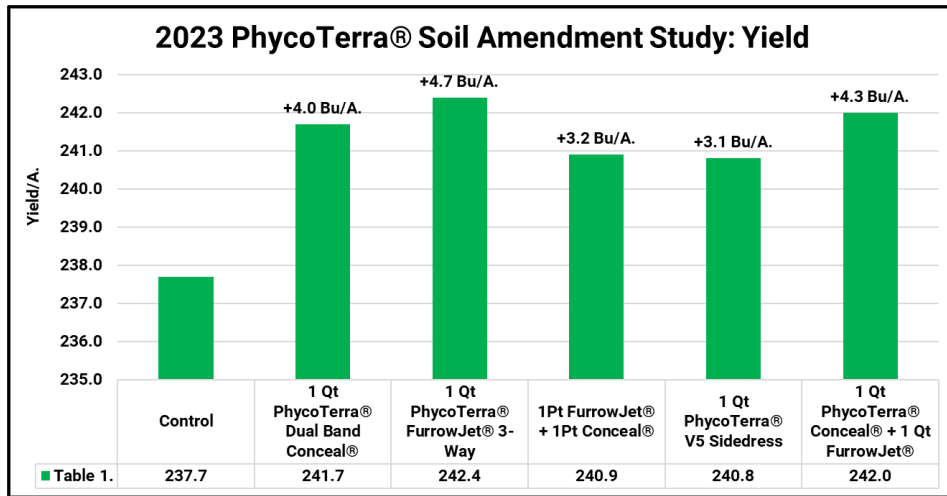


Figure 2. FurrowJet® Placement



PhycoTerra® Conceal® FurrowJet® Soil Amendment Study

Results: All treatments resulted in positive yield gains, as well as economic gain. However, Table 1. illustrates in-furrow treatments of PhycoTerra® resulted in the highest yield gains of +4.7 Bu/A. At a product cost of \$10/A., positive net returns of +\$14.96/A. were realized.



Corn 2023 Summary of Conceal® Applications

PTI Farm Study	Bu/A.	ROI\$/A.
100% Conceal Dual Band over WNF	11.1	\$58.94
Aqua-Yield NanoN+	10.4	\$51.03
25% WNF + 25% Conceal + 50% SD over 50% WNF + 50% SD	13.2	\$48.77
Short Corn Conceal over Control	7.7	\$47.64
Single Band Conceal over WNF	5.6	\$29.74
Dual Band Conceal over Single Band	5.5	\$29.20
75% Conceal Dual Band + 50% SD over 50% WNF + 50% SD	13	\$27.13
50% Conceal Dual Band + 50% SD over 50% WNF + 50% SD	6.7	\$27.09
Xyway	8.14	\$23.54
Short Corn Combo over Control	12.9	\$22.36
K-Fuse 3 Gal	6	\$12.06
PhycoTerra 1qt Dual Band Conceal	4	\$11.24
K-Fuse 5 Gal	7.7	\$7.71
PhycoTerra 1pt Dual Band Conceal + 1pt FurrowJet	3.2	\$6.99
PhycoTerra 1qt Dual Band Conceal + 1qt FurrowJet	4.3	\$2.83
K-Fuse 8 Gal	10.4	\$2.60
Aqua-Yield NanoPack	1.2	\$(0.97)
QLF Boost N Inclusion: 10% N Inclusion + BOOST	0	\$(4.02)
QLF Boost N Inclusion: 25% N Inclusion + BOOST	0	\$(10.49)
Corn Plant Date with Starter - April 13th	9.3	\$(14.46)
100% Conceal Dual Band over 50% WNF + 50% SD	-3.1	\$(19.52)
100% Conceal Single Band over 50% WNF + 50% SD	-2.9	\$(21.04)
Corn Plant Date with Starter - April 24th	7.8	\$(22.43)
Corn Plant Date with Starter - May 5th	7.7	\$(22.96)
25% Conceal Dual Band + 50% SD over 50% WNF + 50% SD	-13	\$(38.05)
Corn Plant Date with Starter - May 18	2.1	\$(52.69)
Corn Plant Date with Starter - June 7th	-0.6	\$(67.03)

Continuous Corn Cover Crop Study

Objective: This trial is designed to evaluate the yield and economic benefits of a cover crop system in a continuous corn rotation. To evaluate long-term benefits, this trial has been designed as a 10-year study. 30#/A. of cereal rye/barley/radish/rapeseed and crimson clover blend was planted in the fall of 2022 and fall strip-till was used as the primary tillage system for corn. In the spring, corn was planted directly on the fall strips into the green cover crop. The cover crop was terminated at 8" in overall height.

Results: Continuous corn planted into our 3rd year of our 10-yr study proved devastating **-36.9 Bu/A.** yield losses compared to a non-cover crop system. These losses resulted in an economic deficit of **-\$245.69.** Due to severe drought conditions in April-June, covers wicked moisture away from corn and caused significant yield losses.

Figure 1. Fall Cover Crop Seeding



Figure 2. Continuous Corn in Cover Crop

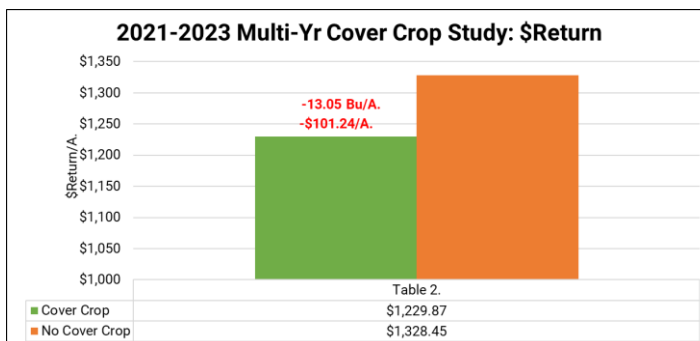
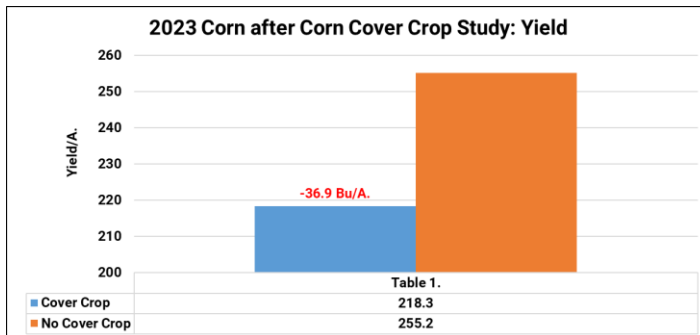


Table 2. illustrates 3-yr data of cover crops in a continuous corn rotation. Over 2021-2023, the PTI Farm has experienced **-13.05 Bu/A** yield losses with economic losses of **-\$101.24/A.**

We look forward to continuing testing the use of cover crops to evaluate yield and economics of the system, while taking a close look at what cover crops can offer regarding soil health improvement. Being in our 3rd year, we are hopeful yield, cash flow, and soil health will improve.

Corn after Soybean Cover Crop Study

Objective: This trial is designed to evaluate the yield and economic benefits of a cover crop system in a corn/soybean corn rotation. To evaluate long-term benefits, this trial has been designed as a 10-year study. A ryegrass/radish/crimson clover blend was planted in the fall of 2022 and fall strip-till was used as the primary tillage system for corn. In the spring, corn was planted directly on the fall strips into the green cover crop. The ryegrass was terminated at when corn reached the V2 growth stage.

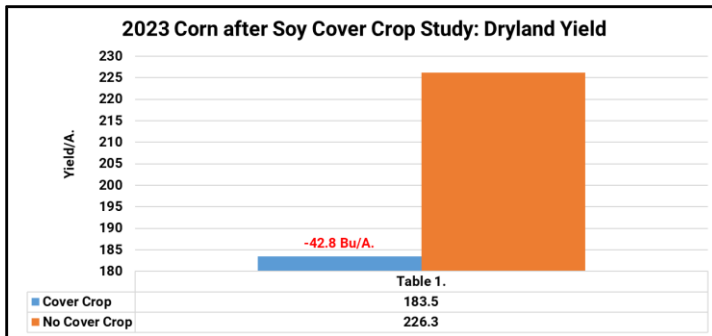


Figure 1. Planting into Strip-Till with Green Cover

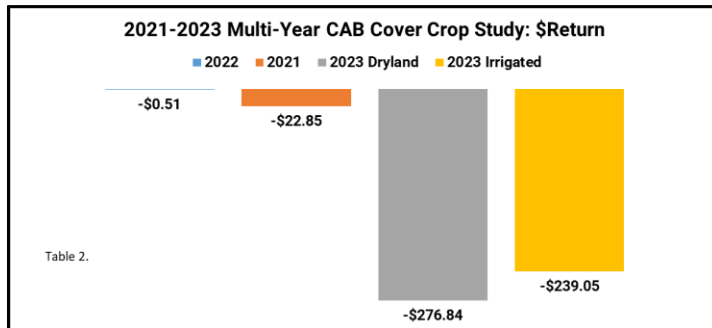


Figure 2. Drought Stressed Corn in Cover Crop



Results: Table 1. illustrates cover crops incurred significant yield losses, mainly due to the severe drought during May and June. Cover crops depleted additional moisture and caused crippling damage to corn. Table 2. Summarizes multi-year data from 2021-2023, where up until this year, losses from cover crops ranged from **-\$0.51/A.** to **-\$22.85/A.**

We look forward to continuing to test the use of cover crops in a corn/soybean rotation and to evaluate yield, economics of the system, while taking a close look at what cover crops can offer regarding soil health improvement over time.

Corn Strip-Cropping Study

Objective: This study evaluates the yield and economic advantages of planting corn and soybeans in alternate 40' strips (Figure 1). The PTI team evaluated this system in 2023 to harvest more sunlight on outside rows with the intention of trying to stimulate higher corn yield. It is quite common to have higher corn yield on the outside field edges (Figure 2.), due to corn being able to harvest more sunlight. However, most often after the first few rows this yield advantage decreases due to more shading of corn biomass. This study is intended to measure any potential yield increases and the associated economics from this system.

In order to understand the agronomics of this strip cropping system, we split our trial design into four segments:

- 40' Corn Blocks (16 rows) planted in North/South rows
- 40' Corn Blocks (16 rows) planted in East/West rows
- 20' Corn Blocks (8 rows) planted in North/South rows
- 20' Corn Blocks (8 rows) planted in East/West rows



Figure 1. 40' Alternate Strips of Corn and Soybeans



Figure 2. Outside Edge of Field

Corn Strip-Cropping Study Continued

Figure 3. illustrates the corn strips in a 40'(16 row 30") block formation. These corn blocks were planted alternatively with 30" soybeans in both a North to South and East to West planting row to allow the ability to study the differences in sunlight shading. In corn, we also implemented the use of "shorter" stature corn being planted on the outside rows of each 40' (16 rows) blocks in an attempt to minimize shading of the soybeans from the corn.

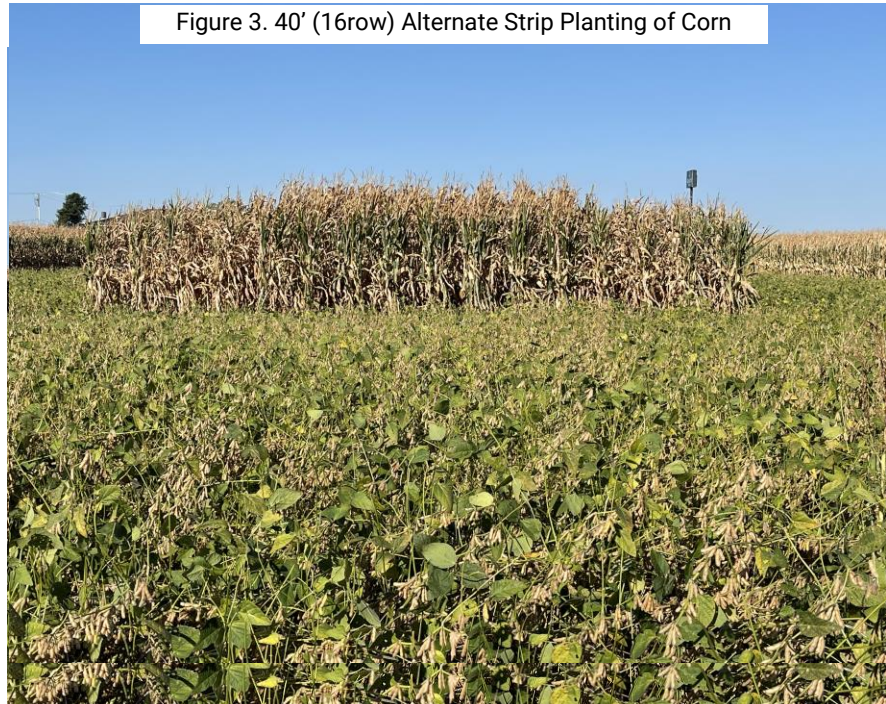


Figure 3. 40' (16row) Alternate Strip Planting of Corn

Figure 4. illustrates corn strip planting in a 20' (8 row 30") block formation. This corn was also planted alternatively with 30" soybeans in both a North to South, as well as an East to West planted row to allow the ability to study the differences in sunlight shading and overall yield differences between wide and narrower corn blocks. Four corn hybrids were used to vary in height from tall to short to help minimize shading effect on the soybeans.



Figure 4. 20' (8row) Alternate Strips of Corn and Soybeans

Corn Strip-Cropping Study Continued

In order to understand the agronomics of the 40' (16 row 30" blocks), we split our 16-row planter into seven individual segments to evaluate yield performance. These seven individual segments were then planted in both north to south and east to west directional planting formations to evaluate the yield and economics on planter row direction.



Rows 1-2

Rows 3-4

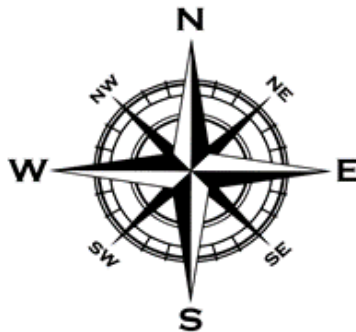
Rows 5-6

Rows 7-10

Rows 11-12

Rows 13-14

Rows 15-16

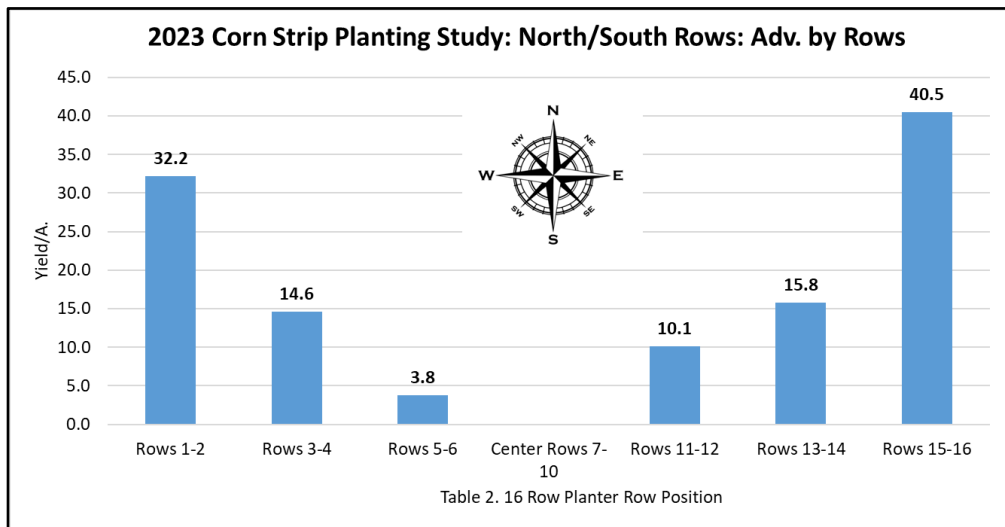
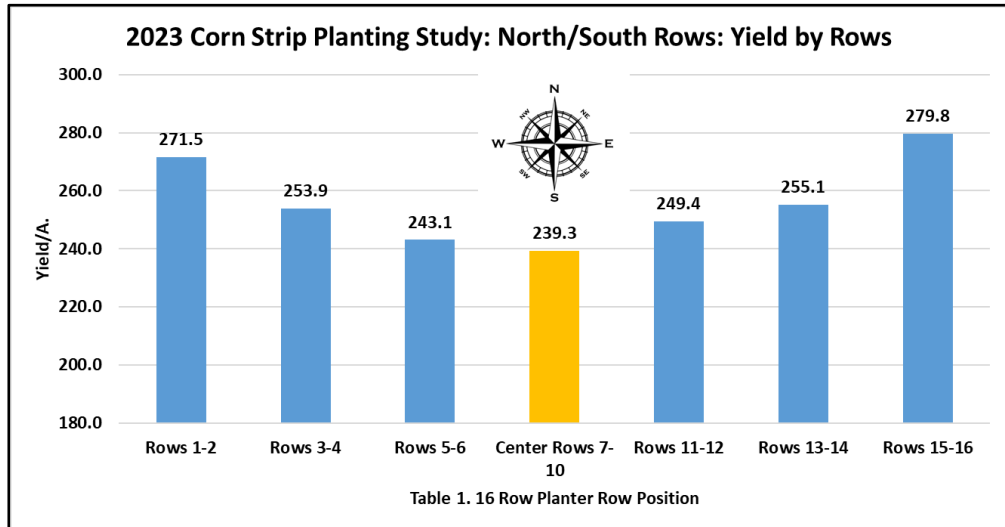


Corn Strip-Cropping Study Continued

Table 1. illustrates the yield response of each planter row segment in the 40' alternate strips planted in a North/South formation. Compared to the center four planter rows, the outside two rows of the planter (rows 1-2 and 15-16) offered average yield advantages of +32.2 to +40.5 Bu/A. Status quo full field planting would equate to 239.3 Bu/A. corn yield (center 4 rows), while this crop stripping experiment increased corn yield to 271.5 Bu/A. to 279.8 Bu/A. on the outside "solar corridor" two rows.

The outside two rows (1-2 and 15-16) increased revenue by +\$170.98/A. to +\$215.06/A. Rows 3-4 and 13-14 increased revenue by +\$77.53 to +\$83.90/A. and finally the inside rows 5-6 and 11-12 offered increases of only +\$20.18/A. to \$53.63/A.

Overall, North/South row strips planted in 40' (16 row) blocks offered **average** yield gains of +19.5 Bu/A. resulting in additional gains of +\$99.80/A.

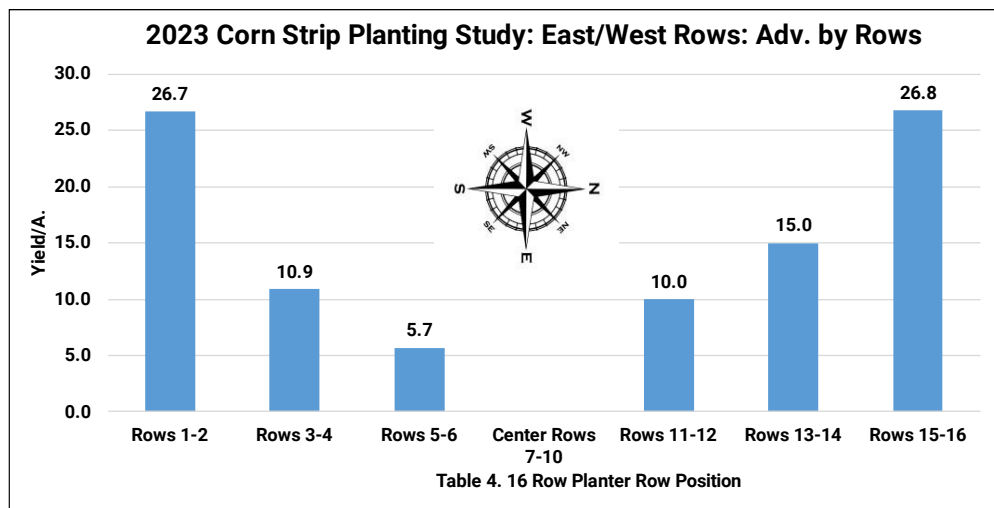
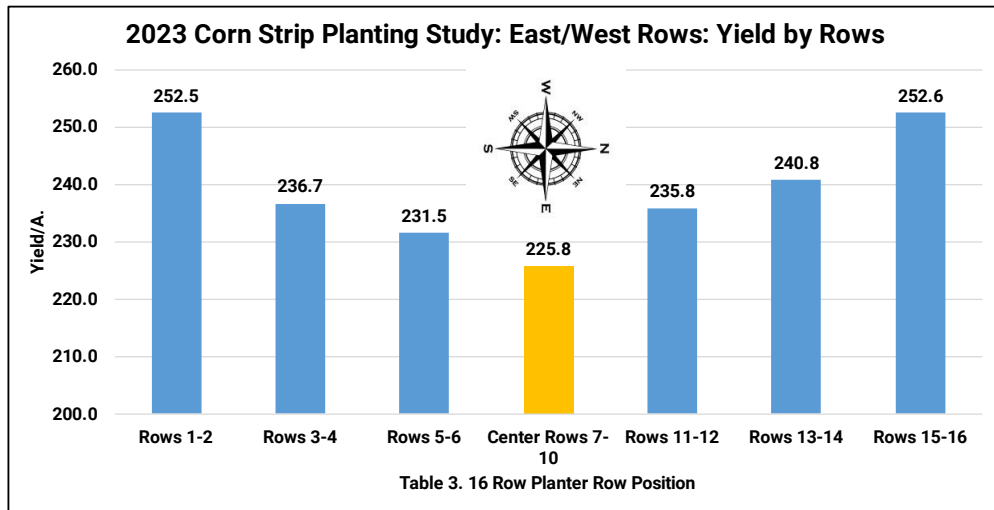


Corn Strip-Cropping Study Continued

Table 3-4. illustrate the yield response of each planter row segment in the 40' alternate strips planted in an east/west formation. Compared to the center four planter rows, the outside two rows of the planter (rows 1-2 and 15-16) again offered incredible average yield advantages of +52.8 to +55.2 Bu/A. Status quo full field planting would equate to 213.4 Bu/A. corn yield (center 4 rows), while this crop stripping experiment increased corn yield to 266.2 Bu/A. and 268.5 Bu/A. on the outside "solar corridor" two rows.

The outside two rows (Rows 1-2 and 15-16) increased revenue from +\$141.78/A. to +\$142.31/A. Rows 3-4 and 13-14 increased revenue by +\$57.88/A. to +\$79.65/A. and finally the inside rows 5-6 and 11-12 offered increases of +\$53.10/A. to +\$30.27/A.

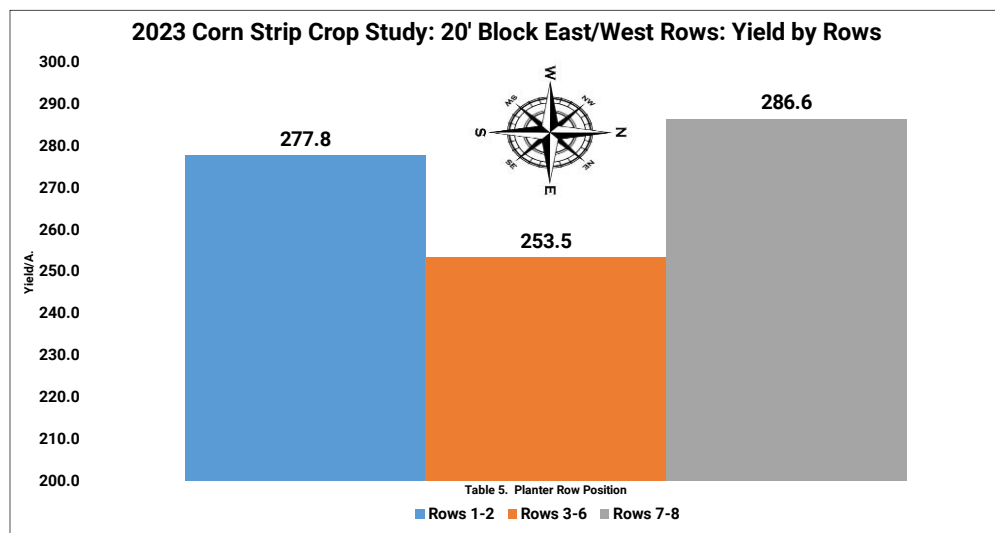
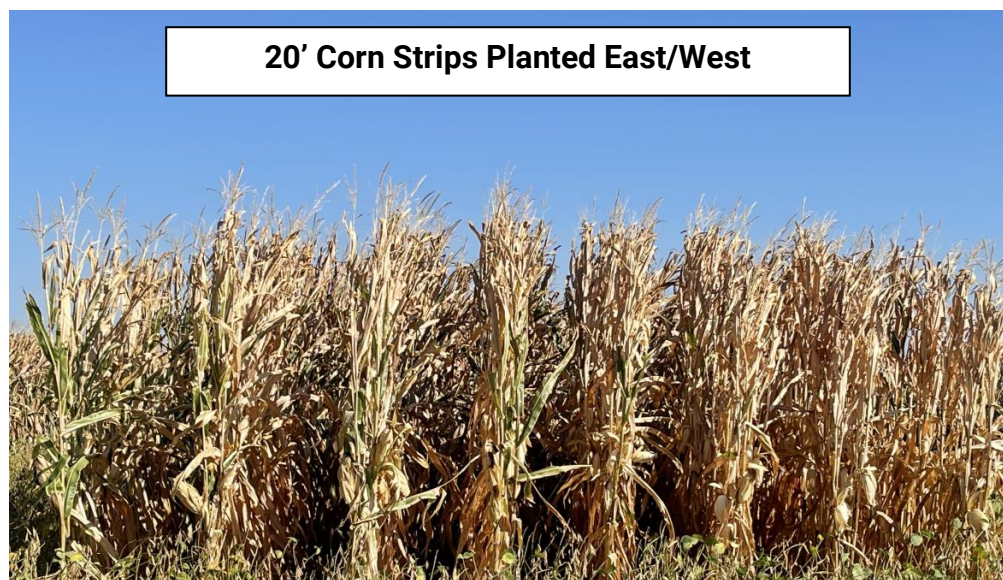
Overall, east/west row strips planted in 40' (16 row) blocks offered **average** yield gains of +15.9 Bu/A. resulting in additional gains of +\$80.41/A.



Corn Strip-Cropping Study Continued

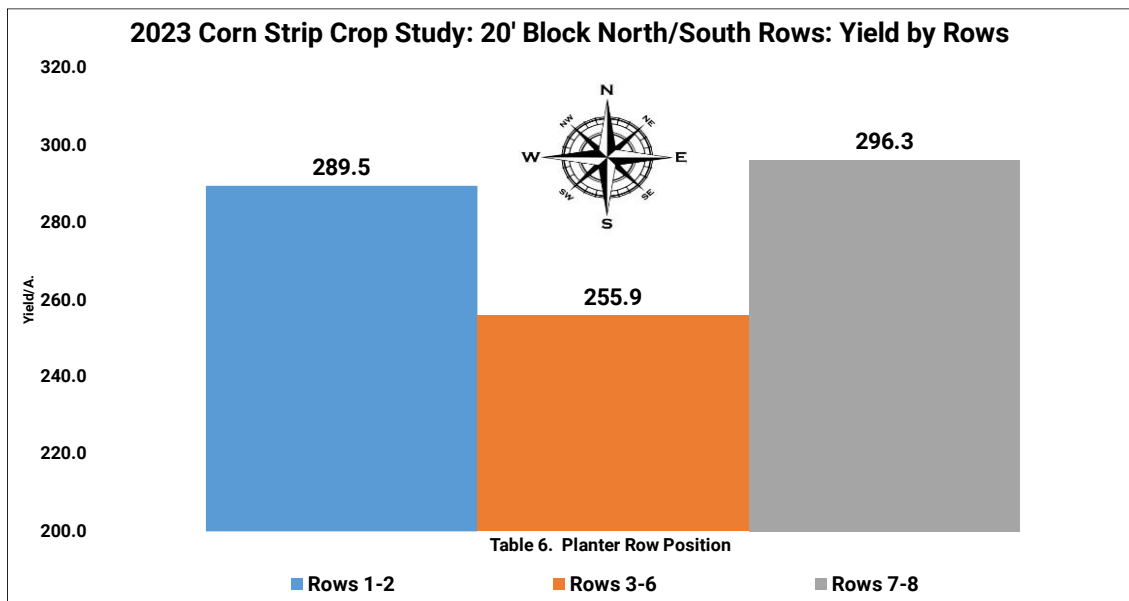
In an effort to understand corn yield in strips by block size, 20' (8 row) blocks were planted with a four-row planter. This smaller configuration allows for more "solar corridor" outside rows and reduces the 40' blocks to half the size.

Table 5. illustrates the yield response of outside versus inside rows in the 20' alternate strips planted in a east/west planting formation. Compared to the center four planter rows, the outside two rows of the planter (rows 1-2, 7-8) offered average yield advantages of +28.7 Bu/A. and +\$152.40/A. in additional revenue. Center section rows averaged 253.5 Bu/A. corn yield, while 277.8 and 286.6 Bu/A. on the outside "solar corridor" rows.



Corn Strip-Cropping Study Continued

Table 6. illustrates the yield response of outside versus inside rows in the 20' alternate strips planted in an north/south planting formation. Compared to the center four planter rows, the outside two rows of the planter (rows 1-2, 7-8) offered average yield advantages of +37 Bu/A. and +\$196.47/A. in additional revenue. Center section rows averaged 255.9 Bu/A. corn yield, while 289.5 and 296.3 Bu/A. on the outside "solar corridor" rows.



Corn Strip-Cropping Study Continued

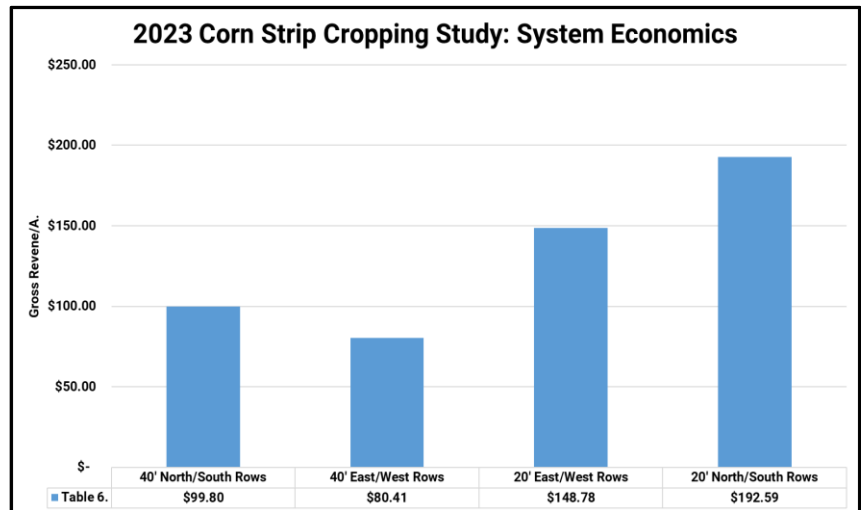
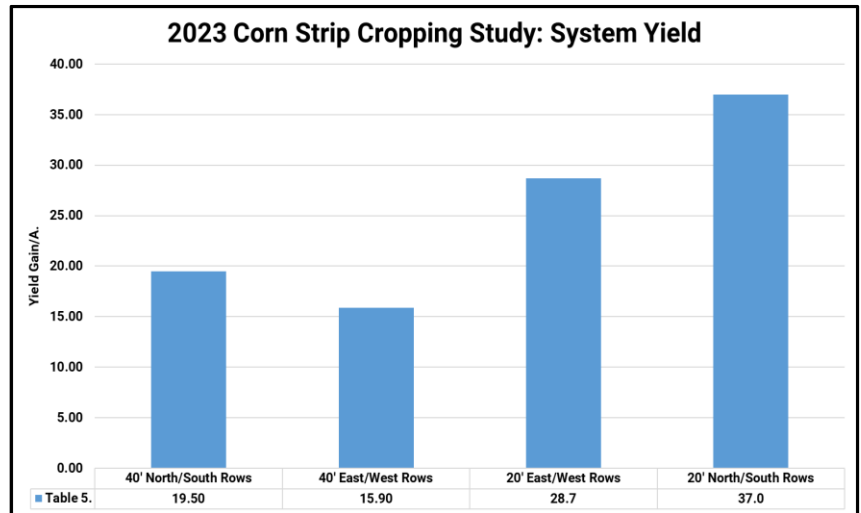
2023 corn strip cropping at the PTI Farm proved to be some of the highest overall revenue contributors on the farm. Table 5. illustrates the yield gains of strip cropping compared to a status quo traditional non-strip row-cropping practice.

40' (16row 30") strips resulted in overall yield gains of +15.9 to +19.5 Bu/A., with north/south rows proving +3.6 Bu/A. over east/west rows.

20' (8row 30") strips resulted in overall yield gains of +28.7 to +37.0 Bu/A., with north/south rows proving +8.3 Bu/A. over east/west rows.

As for economics, Table 6. reveals the overall differences in gross revenue. 40' strips resulted in gains of +\$80.41 to +\$99.80/A., while 20' wide strips tallied impressive gains of +\$148.785 to +\$192.59/A.

At the PTI Farm, we always talk about challenging the status quo and trying to farm smarter each and every season. This strip cropping system, even though challenging to implement with herbicide/nutrient applications and general equipment sizing, proved to create some unbelievable and significant gains. We look forward to continuing testing this system in the future.



Corn Veltyma® Foliar Fungicide Study

Objective: To evaluate the yield and net return of Veltyma® fungicide. Veltyma® contains Revysol®, which is a DeMethylation Inhibitor (DMI) fungicide that is part of the triazole group of fungicides initially labeled for 17 crops, including corn and soybeans. Veltyma® gives excellent control of anthracnose, eye spot, gray leaf spot, northern corn leaf blight, southern corn leaf blight, common rust, southern rust, and tar spot. Veltyma® has a label which expands the window of application from V10-R3.



Active Ingredients*:
 mefentrifluconazole: 2-[4-(4-chlorophenoxy)-2-(trifluoromethyl)phenyl]-1-(1H-1,2,4-triazole-1-yl)propan-2-ol 17.56%
 pyraclostrobin: (carbamic acid, [2-[[[1-(4-chlorophenyl)-1H-pyrazol-3-yl]oxy]methyl]phenyl]methoxy-, methyl ester) 17.56%
Other Ingredients: 64.88%
Total: 100.00%

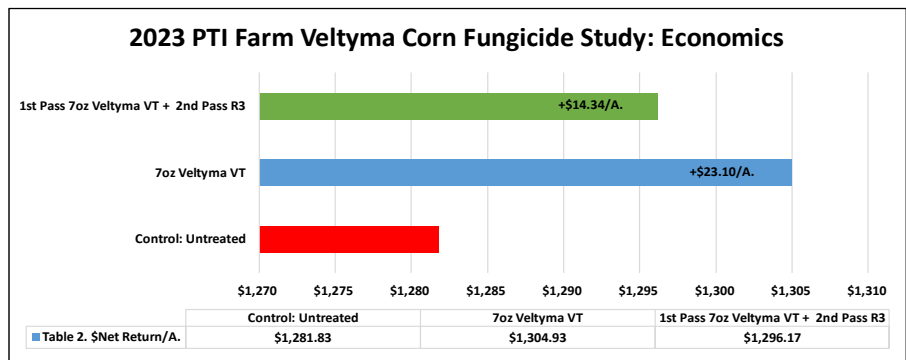
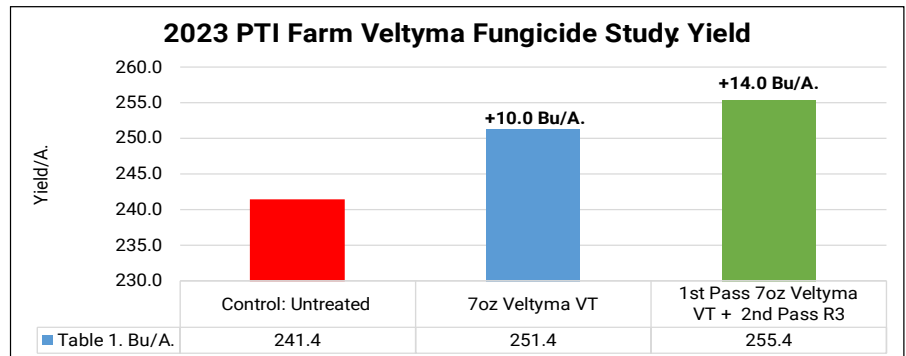
*Veltyma™ fungicide contains 1.67 lbs mefentrifluconazole and 1.67 lbs pyraclostrobin per gallon.
 EPA Reg. No. 7969-409 EPA Est. No.

Mefentrifluconazole	Group	3	Fungicide
Pyraclostrobin	Group	11	Fungicide

Results: Table 1. illustrates that VT foliar applications of Veltyma® resulted in yield gains of +10.0 Bu/A. at the VT growth stage and +14.0 Bu/A. when sprayed at a 2nd pass at R3. This plot had low levels of corn tar spot; however, it was easily found in this particular trial.

After cost of application and fungicide, using a \$5.31 corn price, Veltyma® proved positive net returns of +\$14.34/A. at VT. The 2nd pass R3 treatments resulted in yield gains over the untreated control, however netted losses of -\$8.76/A. compared to stand-alone 1st pass VT treatments.

Figure 1. Tar Spot in Corn



Planting Date: 4/21 Hybrid: Golden Harvest® 08R52 Pop: 36K Row Width: 30" Rotation: CAB Corn Price: \$5.31 Veltyma®+App: \$30/A.

Corn Topguard® EQ Foliar Fungicide Study

Objective: To evaluate the yield and net return of Topguard® fungicide. Topguard® contains flutriafol, which is a Group 3 highly systemic fungicide with translaminar activity that protects the sprayed leaf throughout growing season to help prevent additional disease from developing.

Topguard® fungicide provides long lasting residual protection in corn and protects against key diseases including anthracnose, cercospera leaf blight, frog-eye leaf spot, rusts, leaf blights, powdery mildew, and tar spot.


Results: Table 1 illustrates that foliar applications of Topguard® EQ resulted in a yield advantage of +5.7 Bu/A. when applied at V10, and +7.7 Bu/A. when applied at VT.

Table 1 illustrates sequential treatments of fungicide proved yield advantages of +10.4 Bu/A., and +11.3 Bu/A. respectively.

Table 2. reveals economics of all treatments. After cost of application and fungicide, using a \$5.31 corn price, Topguard® EQ proved economic returns of +\$0.27/A, and +\$10.89/A. on single applications.

Sequential V10/VT treatments resulted in economic losses of **-\$4.78/A.**, while VT/R3 were a net economic wash after the cost of the product and application charge.

FLUTRIAFOL	Group	3	Fungicide
AZOXYSTROBIN	Group	11	Fungicide



For use on almond, barley, brassica leafy vegetables crop group 5, celery and Chinese celery, corn, cotton, cucurbit vegetables, grain sorghum, grapes, leafy vegetables, except brassica, crop group 4, peanuts, pecan, soybeans, stone fruit, strawberry, sugar beets, tomatoes, tree nuts, vegetable, fruiting, group 8-10, wheat, and triticale.

EPA Reg. No. 279-3596 EPA Est. No. 82978-FRA-001

ACTIVE INGREDIENTS: **By Weight**

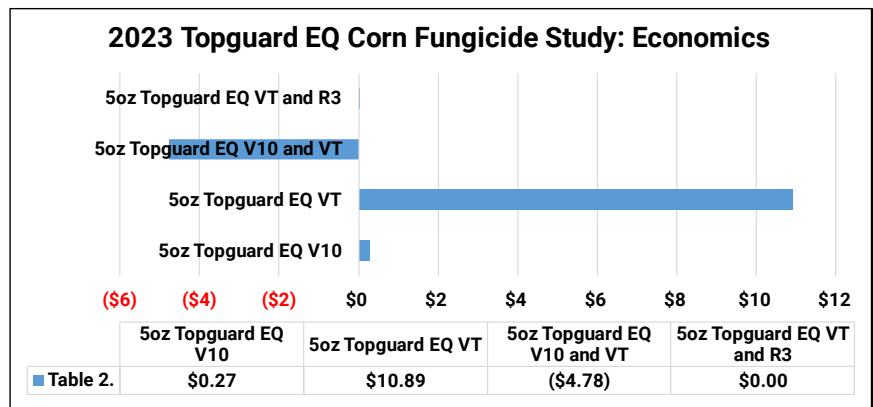
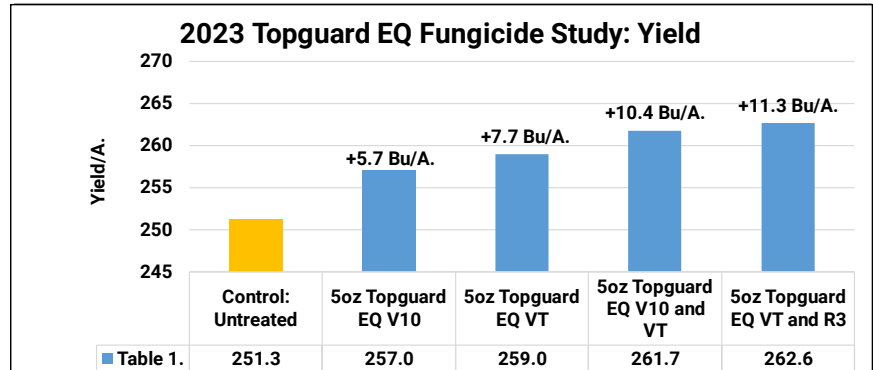
Azoxystrobin: methyl (E)-2-[2-[6-(2-cyanophenoxy) pyrimidin-4-yloxy]phenyl]-3-methoxyacrylate* 25.30%

Flutriafol 18.63%

OTHER INGREDIENTS: 56.07%

TOTAL: 100.00%

Contains 1.82 lb. of flutriafol and 2.47 lb. of azoxystrobin active ingredient per gallon. Suspension Concentrate. *IUPAC



Planting Date: April 21st Hybrid: GH 08R52 Pop: 36K Row Width: 30" Rotation: CAC Corn Price: \$5.31 Topguard® EQ+App: \$30/A.

Miravis® Neo Corn Foliar Fungicide Study

Objective: To evaluate the yield and economics of a Miravis®Neo fungicide.

Miravis®Neo fungicide combines propiconazole, azoxystrobin and Adepidyn technology – one of the most powerful, broad spectrum SDHI molecules available, and delivers superior plant-health benefits and improved preventive and curative control of key diseases such as Gray Leaf Spot, Common and Southern Rust, Tar Spot, Eye Spot, Anthracnose, Diplodia Ear Rot, and Physoderma Brown Spot.

Results: Miravis®Neo treatments at VT growth stage proved yield gains of +8.1 Bu/A. with positive economic returns of +\$16.02/A.

A sequential treatment again at R1, proved additional yield gains of +4.7 Bu/A. but offered **-\$2.03/A** negative return on investment over single VT treatments.

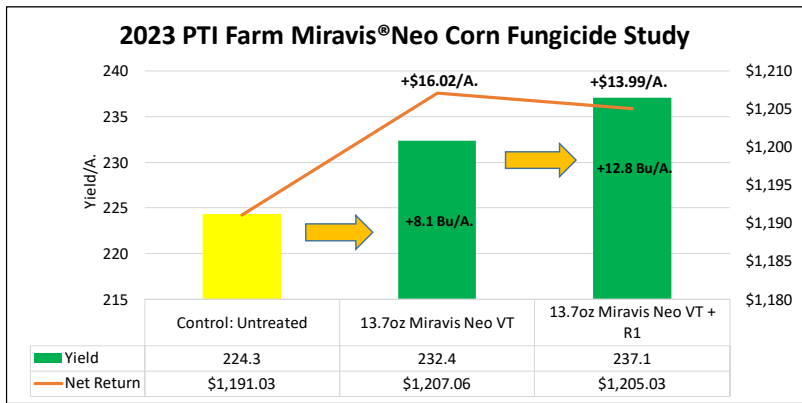
Multi-year data from 2021-2023 growing seasons, over those 3 years Miravis®Neo has proved economic advantages of +\$20.91 when applied at VT, and +\$15.40/A. when sequentially applied at VT+R1.



ADEPIDYN® Technology*

Active Ingredients:

Pydiflumetofen**	PYDIFLUMETOFEN	GROUP 7	FUNGICIDE	
Azoxystrobin***	PROPICONAZOLE	GROUP 3	FUNGICIDE	7.0%
Propiconazole****	AZOXYSTROBIN	GROUP 11	FUNGICIDE	9.3%
Other Ingredients:				11.6%
Total:				72.1%
				100.0%



Fungicide Ground vs. UAV Foliar Spray Application Study

Objective: To evaluate the yield and net return of Trivapro® fungicide applied at VT growth stage.

This study evaluates a traditional ground fungicide application with a Hagie® high-clearance sprayer, at a carrier rate of 15 Gal/A. Additionally, the use of a DJI™ AGRAS T40 spray UAV was also evaluated at carrier rates of 3 Gal/A. (Figure 1).

Trivapro® fungicide is a fungicide for corn, soybeans, and wheat. It contains three robust active ingredients including Solatenol® fungicide, azoxystrobin and propiconazole. Trivapro® is a fungicide product that offers both preventive and curative disease control.



SOLATENOL® Technology*

*Technology denotes the active ingredient, Benzovindiflupyr.

Active Ingredients:

Benzovindiflupyr** : 2.9%

Azoxystrobin*** : 10.5%

Propiconazole**** : 11.9%

Other Ingredients: 74.7%

Total: 100.0%



Figure 2. DJI™ AGRAS T40 UAV



Figure 1. Hagie® Ground Sprayer

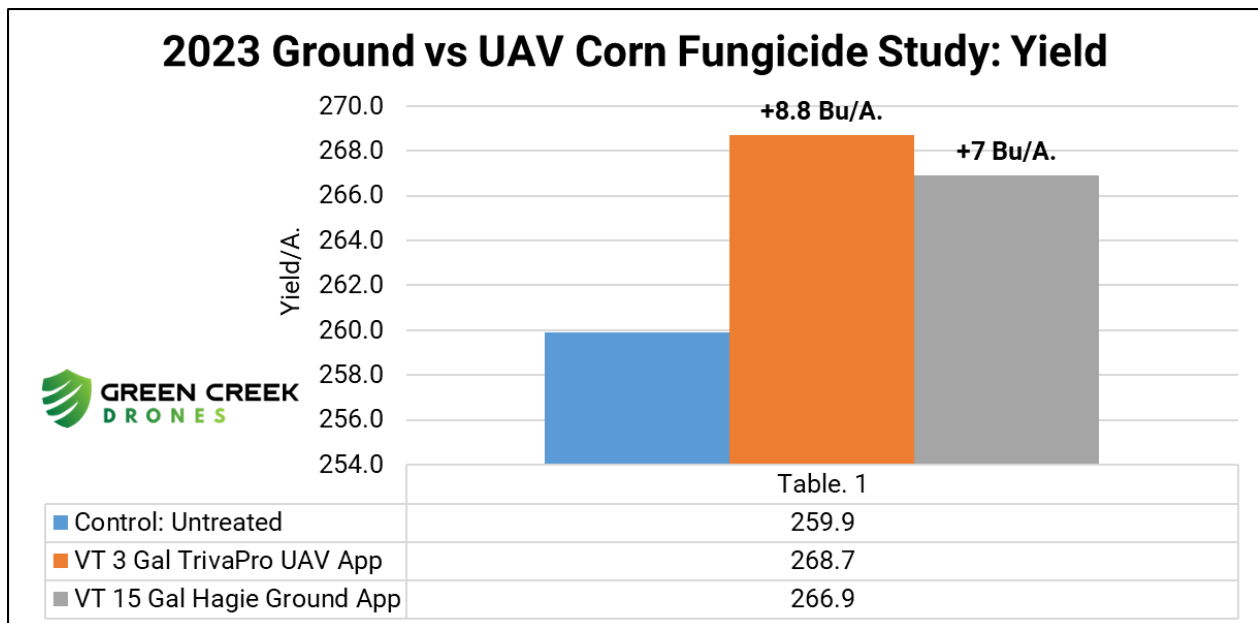


Fungicide Ground vs. UAV Spray Application Study Continued

Results: Table 1. illustrates that VT foliar applications of Trivapro® resulted in yield gains of +7.0 to +8.8 Bu/A. The Hagie® high clearance sprayer and the T40 spray UAV yielding resulted in similar performance, with the UAV tallying higher yields of +1.8 Bu/A. and +\$9.56/A. additional return.

In our 3rd year of evaluating spray UAV applications, it does appear that this technology is an effective method to apply crop protection products, in regard to control. In 2021, the spray UAV applications resulted in +4.5 Bu/A. yield gains with additional revenue of +\$22.50/A. and 2022 offered +1.3 Bu/A. yield gains and +\$7.20/A. additional revenue. (3-yr avg= +2.5 Bu/A., +\$13.09/A.)

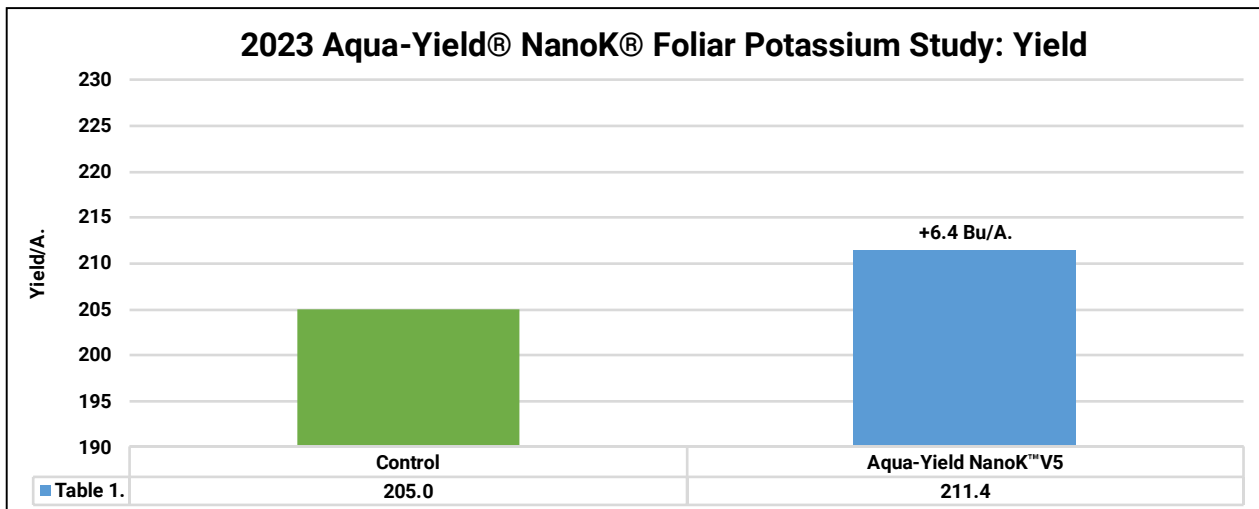
Advantages to UAV technology include precise application due to downward propeller air movement, low carrier rates, the absence of ground or soil engagement, and the ability to spray in fields with topography challenges. Disadvantages include flight time duration, tank capacity, battery charge, and insurance/licensing.



Aqua-Yield® NanoK® Foliar Potassium Study

Objective: To evaluate yield and economics of NanoK® by AQUA-YIELD. NanoK® delivers potassium acetate through Aqua-Yield nanoliquid technology. Potassium is a vital nutrient for plant growth, and NanoK® ensures a strong plant structure resulting in enhanced crop quality and yield. NanoK also decreases drought stress and boosts the plant’s immune system to fight off disease.

This trial aims to establish the efficiency of Aqua-Yield’s NanoK® as a foliar based application of 4oz/A. at the V5 growth stage.



AQUA-YIELD®

NanoK®

Aqua-Yield® NanoK® Foliar Potassium Study Continued

Results: Table 1. illustrates yield results of all treatments. Aqua-Yield’s NanoK® resulted in +6.4 Bu/A. yield improvement over the control.

Table 2. summarizes the overall economics of the foliar fertility study where NanoK® resulted in positive economic gains of +\$26.92/A.

Figure 1. below is a recent soil test from the PTI Farm. Base saturation K levels indicate low levels of 2.0 to 2.8%, when nearer to 4% would be optimum. This may help explain as to the reason for the nice response of NanoK®. Potassium continues to be a concern and goal/challenge to correct at the PTI Farm.

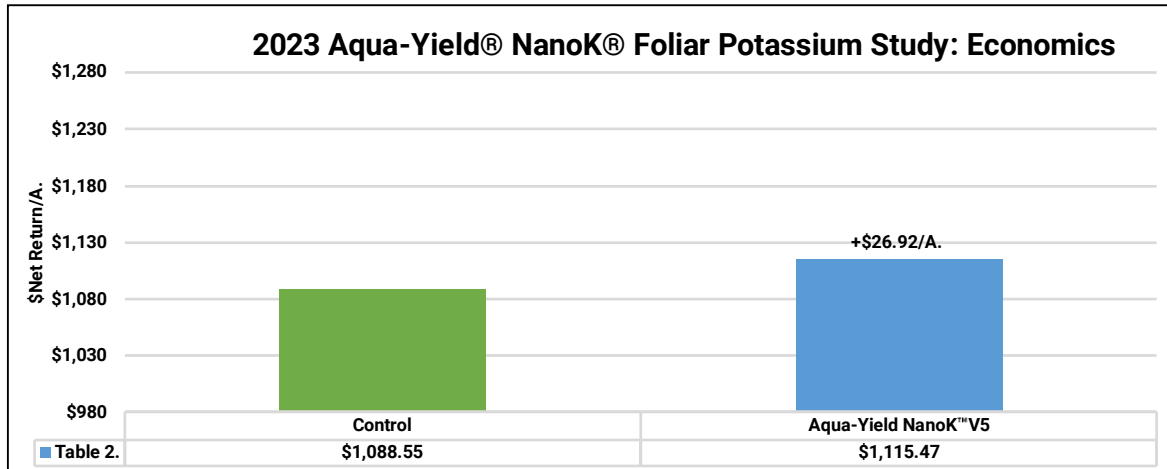


Figure 1: Soil Test Results at PTI Farm

SOIL ANALYSIS REPORT																						
ORGANIC MATTER L.O.I. percent	PHOSPHORUS						NEUTRAL AMMONIUM ACETATE (EXCHANGEABLE)				pH		CATION EXCHANGE CAPACITY C.E.C. meq/100g	PERCENT BASE SATURATION (COMPUTED)								
	P (WEAK BRAY) 1:7		P (STRONG BRAY) 1:7		OLSEN BICARBONATE P		POTASSIUM K		MAGNESIUM Mg		CALCIUM Ca			SODIUM Na		SOIL pH 1:1	BUFFER INDEX	% K	% Mg	% Ca	% H	% Na
	RATE	RATE	RATE	RATE	RATE	RATE	ppm	RATE	ppm	RATE	ppm	RATE		ppm	RATE	1:1	INDEX	meq/100g				
4.9 VH	35 VH	66 VH				228 M	601 VH	4179 H	10	6.3	6.6	29.6	2.0	16.9	70.6	10.4	0.1					
3.5 M	33 VH	54 H				168 M	309 VH	3008 H	9	6.1	6.6	21.0	2.1	12.3	71.6	13.8	0.2					
4.1 H	38 VH	68 VH				258 VH	372 VH	3528 H	9	6.3	6.7	23.9	2.8	13.0	73.8	10.2	0.2					

Aqua-Yield® NanoPro® Foliar Fungicide Study

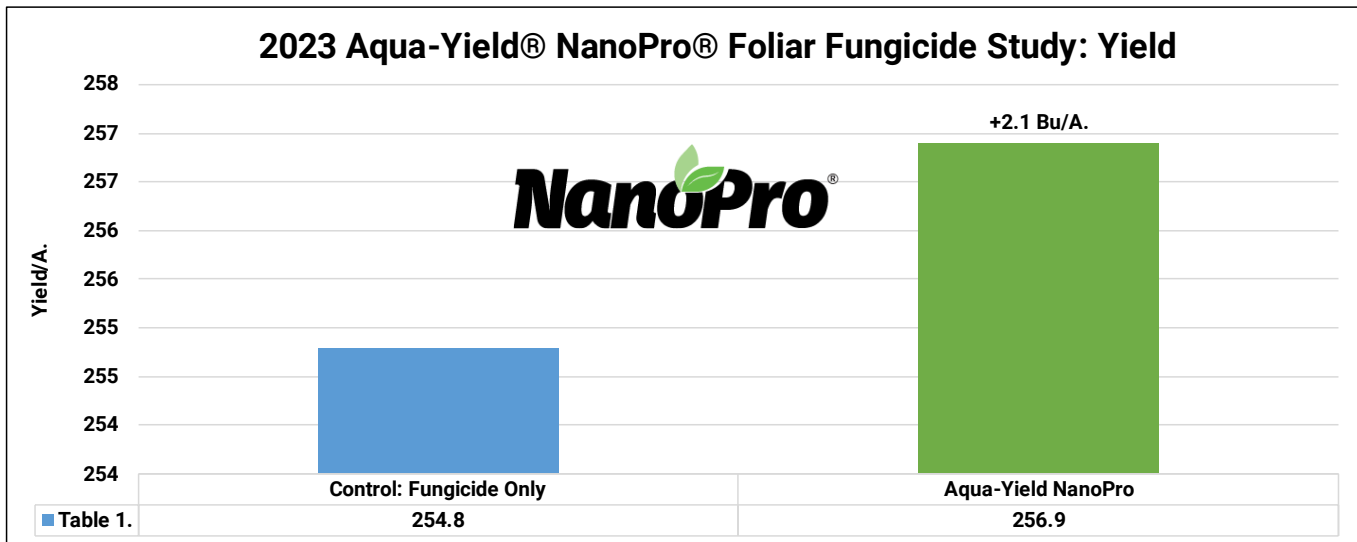
Objective: To evaluate yield and economics of NanoPro® by AQUA-YIELD®. NanoPro® is a carrier adjuvant that enhances the uptake of crop protection products.

This trial aims to establish the efficiency of Aqua-Yield’s NanoPro® as a tank-mix partner with a corn fungicide applied at the VT growth stage (13.7oz/A. Miravis® Neo).



Results: Table 1. illustrates Aqua-Yield’s NanoPro® resulted in +2.1 Bu/A. yield improvement over the control of a standard fungicide application at VT growth stage.

With a +2.1 Bu/A. yield response, economics would suggest that NanoPro® resulted in positive economic gains of +\$8.24/A.

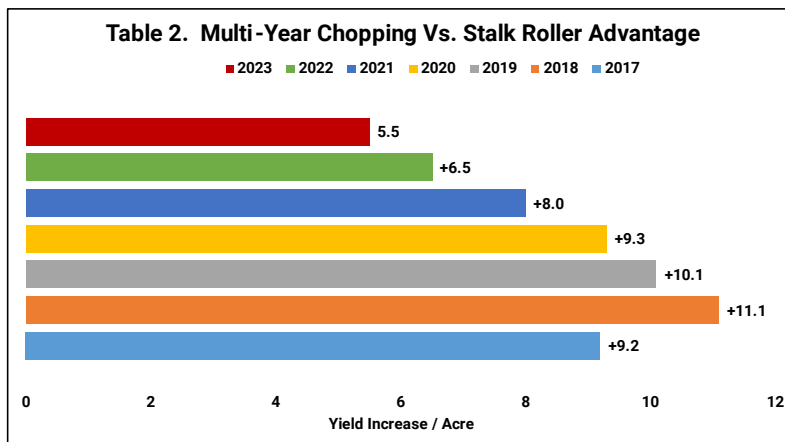
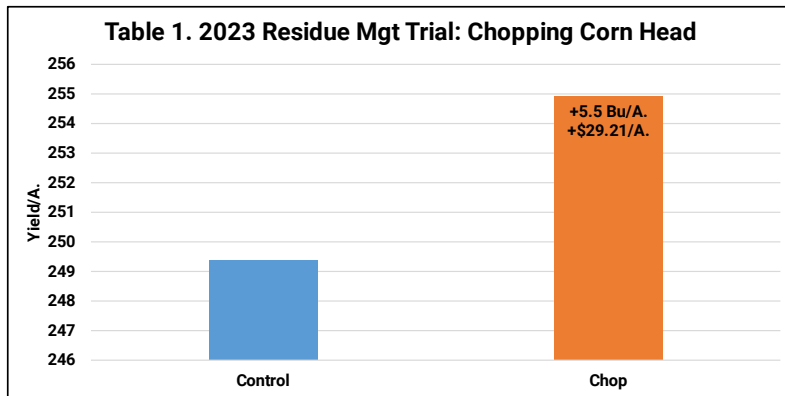


Chopping Corn Head Study

Objective: To study the yield impact of utilizing a chopping corn head in a continuous corn conventional tillage rotation. A Capello DIAMANT™ chopping head is used to create replicated strips of chop and non-chop residue management trials. The goal of this trial is to evaluate sizing of residue, allowing heavy stalks and residue to break down faster to advance the degradation process and in turn, reducing the carbon penalty associated with continuous corn environment.

Results: Table 1. illustrates that chopping corn residue improved corn yields by +5.5 Bu/A. and increased gross revenue by +\$29.21/A. at a corn commodity price of \$5.31/Bu.

Multi-year data from 2017-2023 indicates consistent results with chopping advantages of +5.5 to +11.1 Bu/A.



Planting Date: May 15th Hybrid: DKC 59-82VT2P Population: 36.5K Row Width: 30" Rotation: CAC Corn Price: \$5.31

Phantom Yield Loss Study: Commercial Drying Cost

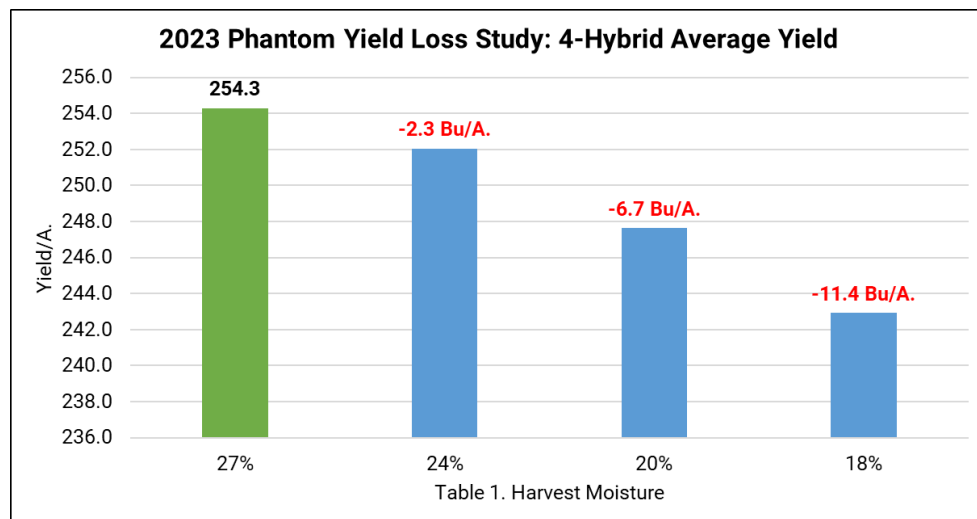
Objective: To evaluate yield and economics of harvesting multiple corn hybrids at earlier and later harvest intervals of 27%, 24%, 20% and 18% grain moisture levels. The goal of this study is to determine if higher moisture grain at harvest offers higher yields and if so, is there a “phantom” yield loss that occurs when corn harvest occurs at lower grain moistures?

Many times at the PTI Farm, corn harvest gets delayed due to weather or even switching crops to harvest soybeans. It is not common during this moisture transition in corn to observe lower actual yield when corn harvest begins again at lower moisture grain levels. This phenomenon is called by many farmers as “invisible” or “phantom” yield loss.

Why does corn potentially yield less as grain moisture levels decrease naturally in the field? The following are factors that could contribute to phantom yield losses:

1. Wind Damage and/or Stalk Lodging
2. Ear Rots Leading to Kernel Damage
3. Insect Damage Leading to Kernel Damage
4. Dry Matter Loss from Respiration
5. Increased Butt Shelling at Corn Head
6. Increased Fines Due to Cracked Dry Kernels

Results: Four corn hybrids were used in this study including DeKalb 66-06, 61-40, 111-35, and Golden Harvest 02K90. Each hybrid was harvested at grain moisture levels of 27%, 24%, 20% and 18%. Average yield at 27% moisture, resulted in 254.3 Bu/A., however, Table 1. illustrates average yield loss at each moisture level under the 27% base-line. At 24% moisture, corn yield decreased by **-2.3 Bu/A.**, at 20%, and **-11.4 Bu/A.** at 18%.



Phantom Yield Loss Study: Commercial Drying Rates

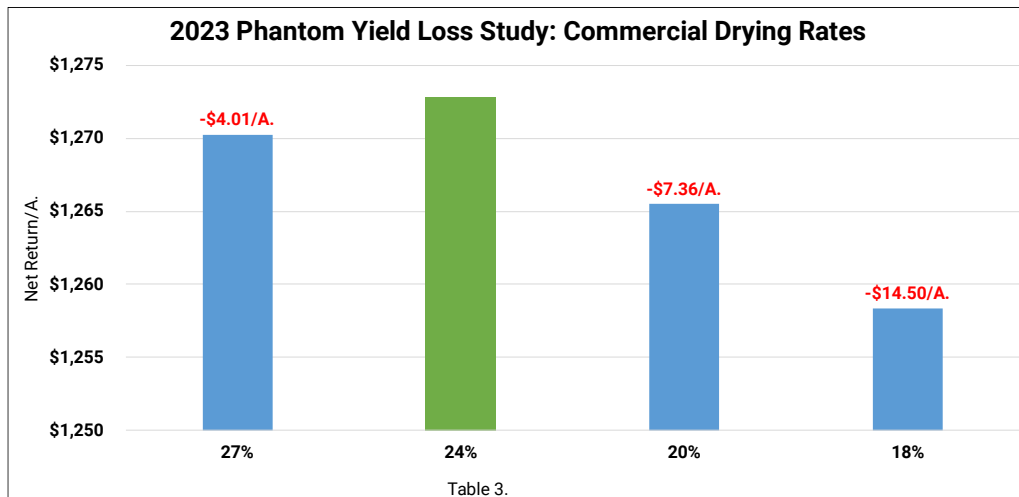
Even though corn yield achieved highest yield at high moisture levels of 27%, the cost of drying that high moisture corn needs to be taken into account for economics. Using commercial local grain elevator pricing for each moisture level of 27%, 24%, 20% and 18% (Table 2.), net return was then calculated. Table 3. illustrates 24% moisture corn realized highest overall net return for all 4 corn hybrids. Higher in field moistures of 27% resulted overall losses, however minimal at only **-\$4.01/A.**

27%:	\$0.315/Bu.
24%:	\$0.26/Bu.
20%:	\$0.20/Bu.
18%:	\$0.13/Bu.

As corn harvest moisture was allowed to naturally dry to 20%, net return losses of **-\$7.36/A.** were realized. However, the highest losses occurred at the lowest moisture levels of 18% with average economic deficit of **-\$14.50/A.**

It should be noted that on-farm drying would allow for lower cost of drying higher moisture corn, which would lead to higher net losses potentially from phantom yield loss.

As a only a 1st year study at the PTI Farm, we look forward to evaluated phantom yield loss of various corn hybrids in the future. We anticipate that growing degree days and overall general weather conditions may impact yield response. As a multi-year study going forward, we hope to glean more knowledge from this agronomic study.



Phantom Yield Loss Study: On-Farm Drying Cost

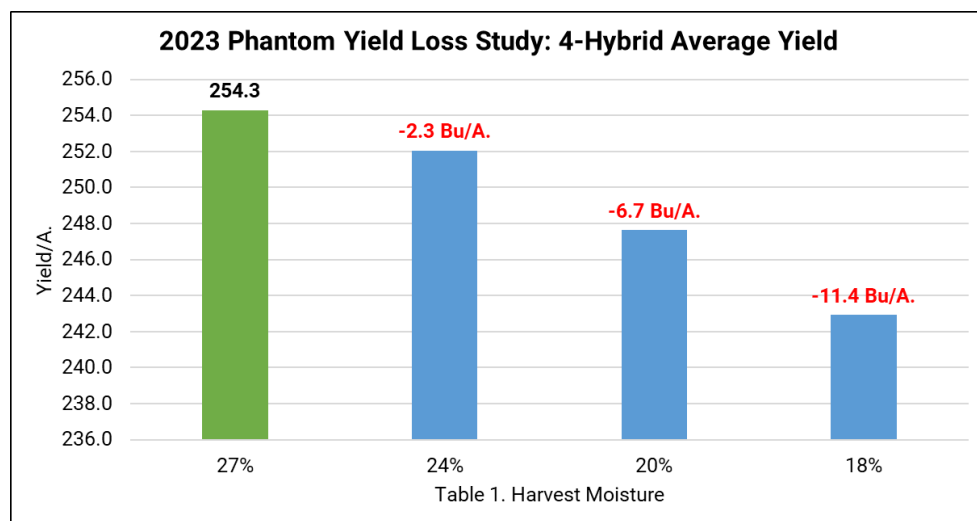
Objective: To evaluate yield and economics of harvesting multiple corn hybrids at earlier and later harvest intervals of 27%, 24%, 20% and 18% grain moisture levels. The goal of this study is to determine if higher moisture grain at harvest offers higher yields and if so, is there a “phantom” yield loss that occurs when corn harvest occurs at lower grain moistures?

Many times at the PTI Farm, corn harvest gets delayed due to weather or even switching crops to harvest soybeans. It is not common during this moisture transition in corn to observe lower actual yield when corn harvest begins again at lower moisture grain levels. This phenomenon is called by many farmers as “invisible” or “phantom” yield loss.

Why does corn potentially yield less as grain moisture levels decrease naturally in the field? The following are factors that could contribute to phantom yield losses:

7. Wind Damage and/or Stalk Lodging
8. Ear Rots Leading to Kernel Damage
9. Insect Damage Leading to Kernel Damage
10. Dry Matter Loss from Respiration
11. Increased Butt Shelling at Corn Head
12. Increased Fines Due to Cracked Dry Kernels

Results: Four corn hybrids were used in this study including DeKalb 66-06, 61-40, 111-35, and Golden Harvest 02K90. Each hybrid was harvested at grain moisture levels of 27%, 24%, 20% and 18%. Average yield at 27% moisture, resulted in 254.3 Bu/A. However, Table 1. illustrates average yield loss at each moisture level under the 27% base-line. At 24% moisture, corn yield decreased by **-2.3 Bu/A.**, **-6.7 Bu/A.** at 20%, and **-11.4 Bu/A.** at 18%.



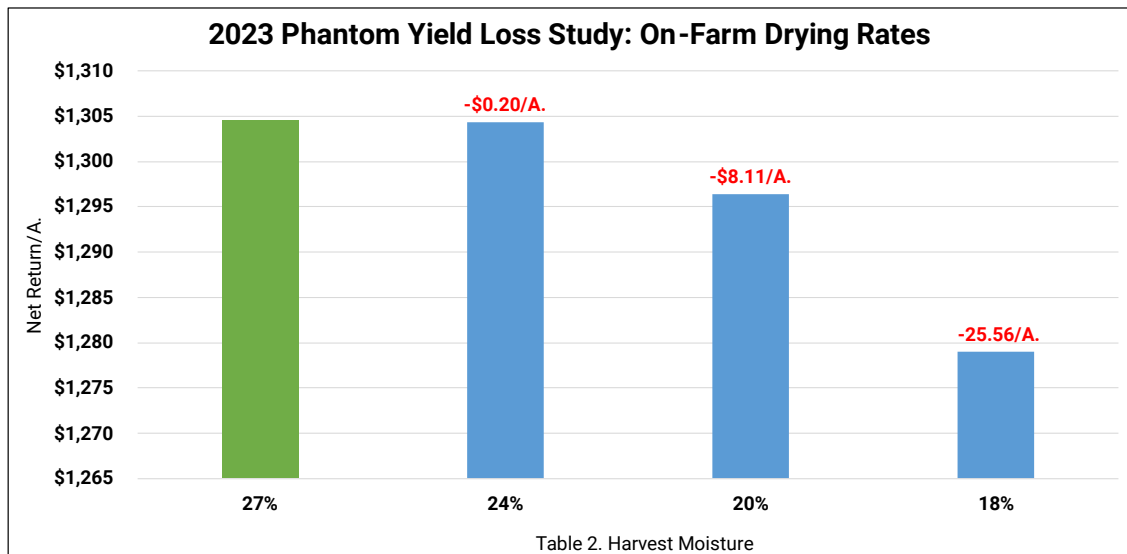
Phantom Yield Loss Study: On-Farm Drying Rates

Even though corn yield achieved highest yield at high moisture levels of 27%, the cost of drying that high moisture corn needs to be taken into account for economics. Using commercial local grain elevator pricing for each moisture level of 27%, 24%, 20% and 18% (Table 2.), net return was then calculated. Table 3. illustrates 27% moisture corn realized highest overall net return for all 4 corn hybrids. Lower field moistures of 24% resulted in overall losses, however minimal at only **-\$0.20/A.**

27%:	\$0.315/Bu.
24%:	\$0.26/Bu.
20%:	\$0.20/Bu.
18%:	\$0.13/Bu.

As corn harvest moisture was allowed to naturally dry to 20%, net return losses of **-\$8.11/A.** were realized. However, the highest losses occurred at the lowest moisture levels of 18% with average economic deficit of **-\$25.56/A.**

As a only a 1st year study at the PTI Farm, we look forward to evaluated phantom yield loss of various corn hybrids in the future. We anticipate that growing degree days and overall general weather conditions may impact yield response. As a multi-year study going forward, we hope to glean more knowledge from this agronomic study.

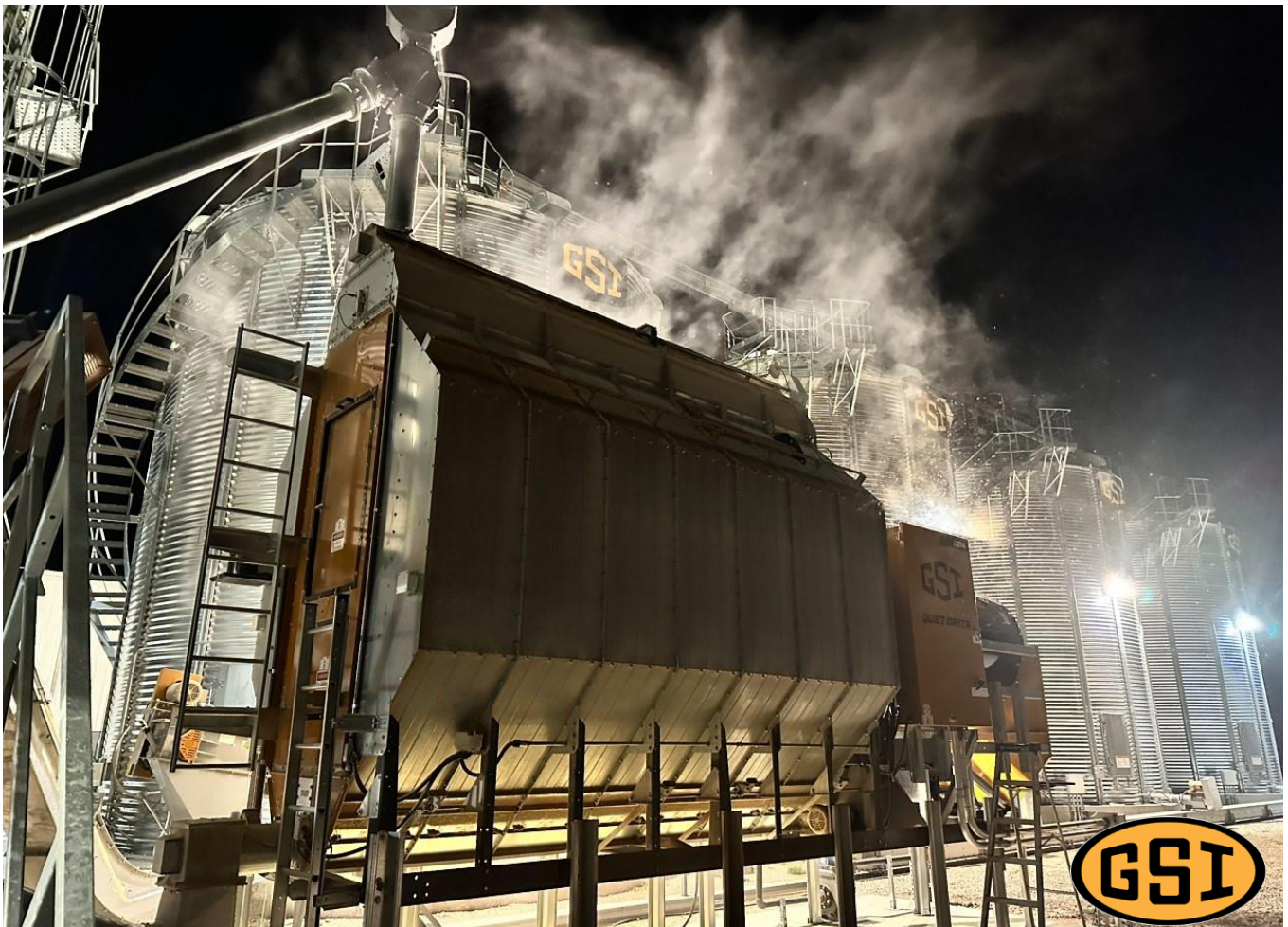


On-Farm Drying and Storage Study

Objective: To evaluate overall economic benefit of an on-farm grain storage and drying facility. This study will compare drying and storing corn on the farm, versus a typical grower taking their grain to a commercial grain terminal at harvest.

The PTI Farm partnered with GSI Grain Systems on the construction of a new grain storage facility with a GSI Q214 continuous flow dryer (Figure 1). This \$1,000,000 facility is used to dry and store corn from grain harvest at the PTI Farm. To calculate overall return on investment, this study is based on an average grower size of 1500 acres annually of corn with average yields of 240 Bu/A. and 140,000 bushels of storage.

Figure 1. GSI Grain Storage Facility with Q214 Quiet Dryer



On-Farm Drying and Storage Study

Results: As the PTI Farm team evaluated the ability to dry and store corn at the farm, four main advantages were quickly realized from using the GSI grain system:

1. Cost of Drying: Estimated Annual Savings +\$28.80/A.

Table 1. illustrates cost of drying corn at a local grain terminal that the PTI Farm delivers grain to each harvest. Its is very typical for grain harvest moisture to be near 24%. With 240 Bu/A. corn, this grain moisture would equate to \$62.40/A. drying charges commercially.

With the GSI Q214 continuous flow dryer, using propane gas, drying charges averaged \$0.015/moisture point/bushel.

27%:	\$0.315/Bu.
24%:	\$0.26/Bu.
20%:	\$0.20/Bu.
18%:	\$0.13/Bu.

Table 2. summarizes average grain moisture throughout the 2023 harvest at the PTI Farm and the % of total acres harvested at that moisture level. 10% of total acres were harvested at 27% corn, 50% at 24% corn, 25% at 20% corn and 15% of our acreage at 18% moisture. Due to late construction completion, a lower amount of 27%-24% moisture corn was actually harvested. We would expect these values to shift to higher percentages of wet corn, in the future.

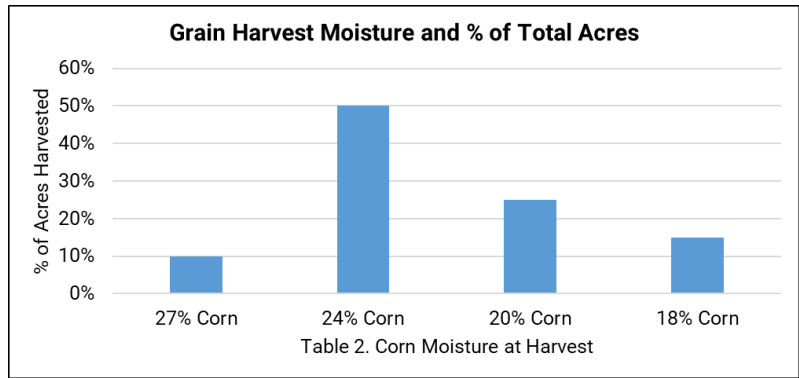
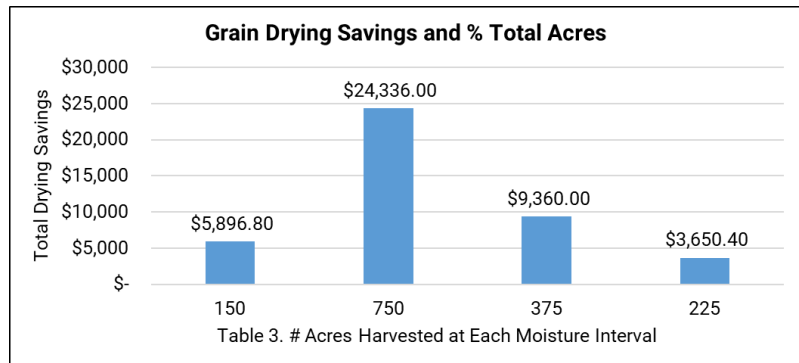


Table 3. summarizes total grain drying savings by harvest moisture. Tallying each harvest moisture level, corn averaging 240 Bu/A. would equate to grower savings of drying cost of \$43,243.20, which would average +\$28.80/A.



On-Farm Drying and Storage Study

2. Shrink Savings: Estimated Annual Savings +\$2.85/A.

One of the expenses involved in drying corn is the "cost" of the weight loss that occurs during the drying process. This weight loss is referred to as "shrink" and is expressed as a percentage of the original quantity before it is dried.

Total grain weight or number of actual bushels is determined after shrink is deducted from gross weight at wet moisture. Table 4. illustrates water shrink at grain moisture levels from 15.5% to 7%. It is common today for growers to have final grain moistures ranging from 14% to 15%, depending upon storage or sale of grain upon delivery.

At 15% corn moisture, the total water shrink is 1.176%. However, it is common in this area for grain buyers to charge 1.4% shrink as a common deduction for every bushel a grower delivers, no matter the grain moisture level.

This additional 0.224% shrink charge is an "over-charge" to the grower and manipulated as a "grain handling" fee. Grain buyers upcharge shrink to cover their cost of grain losses due to broken kernels, foreign matter, spoilage, or respiration of seed.

On 1500 total acres of corn at 240 Bu/A., upcharge shrink (at 15%) would equate to 806.4 bushels of corn,. This is simply corn donated to the grain buyer to cover grain handling losses. At \$5.31/Bu. corn price, this additional expense to the grower tallies \$4281.98 or \$2.85/A.

Table 4. Water Shrink Factors for Drying Shelled Corn

<u>Final Moisture%</u>	<u>Content</u>	<u>%Shrink/Moisture Point</u>
15.5		1.183
15.0		1.176
14.0		1.163
13.0		1.149
12.0		1.136
11.0		1.126
10.0		1.111
9.0		1.099
8.0		1.087
7.0		1.000

Source: Purdue University Extension



On-Farm Drying and Storage Study

3. Phantom Yield Loss Savings: Estimated Annual Savings +\$5.96/A.

Many times at the PTI Farm, corn harvest gets delayed due to weather or even switching crops to harvest soybeans. It is not common during this moisture transition in corn to observe lower actual yield when corn harvest begins again at lower moisture grain levels. This phenomenon is called by many farmers as “invisible” or “phantom” yield loss.

Why does corn potentially yield less as grain moisture levels decrease naturally in the field? The following are factors that could contribute to phantom yield losses:

1. Wind Damage, Ear Drop and/or Stalk Lodging
2. Ear Rots Leading to Kernel Damage
3. Insect Damage Leading to Kernel Damage
4. Dry Matter Loss from Respiration
5. Increased Butt Shelling at Corn Head
6. Increased Fines Due to Cracked Dry Kernels

Table 5. illustrates average yield losses of four corn hybrids at the PTI Farm when harvested at moisture levels of 27%, 24%, 20% and 18%. Using on-farm drying with the GSI system, 27% corn was economic optimum harvest moisture. As moisture levels dropped to 24%, yield fell by **-2.3 Bu/A.**, 20% at **-6.7 Bu/A.** and 18% at **-11.4 Bu/A.** losses.

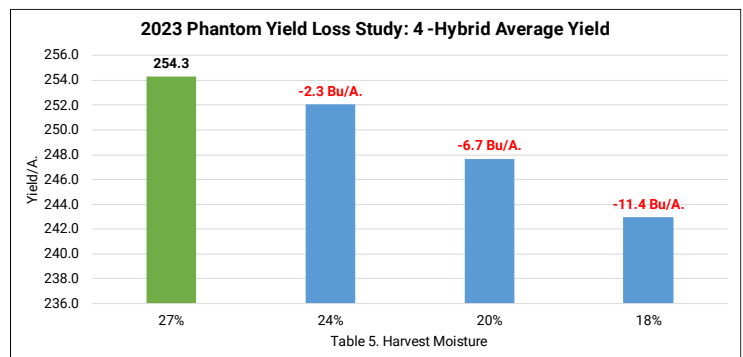
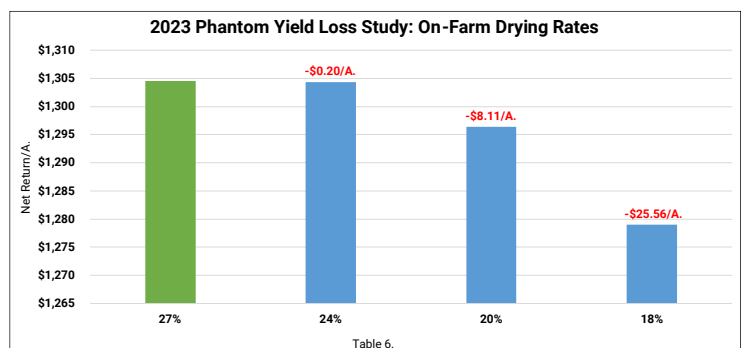


Table 6. summarizes the economics of the four hybrids at each harvest moisture. 18% moisture corn realized losses of **-\$25.56/A.**, 20% at **-\$8.11/A.** and 24% at **-\$0.20/A.**



Overall, gains from eliminating phantom yield loss would average +\$5.96/A.

On-Farm Drying and Storage Study

4. Seasonal Price Difference: Estimated Annual Savings +\$24.78/A.

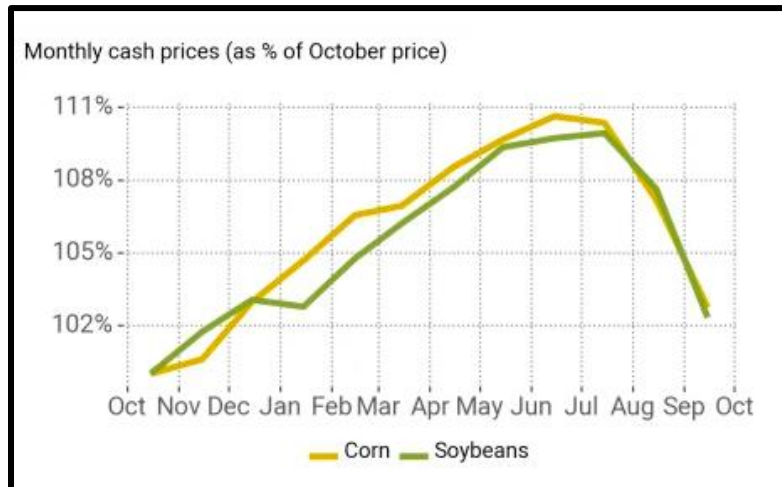
An important benefit of on-farm grain storage is the ability to take advantage of carry in the grain market. Grain price “carry” refers to a situation where futures prices for a commodity increase over time, resulting in a higher price for delivery at a future date.

Seasonal price difference or carry in the market can occur for many reasons, such as a tight commodity supply or a growing demand due to weather events. Growers can take advantage of carry in the market by storing their grain and selling it later when prices are higher. Any grain premiums available could also factor into a potential marketing gain as well.

Being our 1st year of this study, actual on-farm grain pricing cannot be evaluated. However, if we look at historical data, Table 7. below shows monthly cash prices for corn and soybeans for the 2010 through 2022 marketing years. Holding grain in on-farm storage until the following spring resulted in prices 5-10% higher than those available during harvest months. Using a 10% increase in price due to carry in the market, this would equate to +\$0.53/Bu. increase in sale price of corn.

This increase in grain sale would add +\$74,340 of revenue on the 140,000 bushels of total grains stored in the system, corresponding to an average benefit of +\$49.56/A.

Table 7. Source: USDA National Agricultural Statistics



On-Farm Drying and Storage Study

In our first year of testing our new GSI Systems grain storage and drying facility, we uncovered four practices that did or could in fact offer yield or economic advantages.

Calculated overall savings contributed a total +\$87.17/A. in additional revenue and/or savings of expense for a return of investment of +13%.

With the cost of the facility at \$1,000,000, the facility would pay for itself in approximately 7.6 crop years.

2023 PTI Farm GSI Grain Storage and Drying Study

1. Cost of Drying Corn	+\$28.80
2. Corn Shrink Reduction	+ \$2.85
3. Phantom Yield Loss Reduction	+ \$5.96
4. Price Carry in the Market	+\$49.56

Total Savings +\$87.17

Total Investment:	\$1,000,000
Total Investment by Acre:	\$666.70
Years to Break-Even on Investment:	7.6 Years*

*No calculated Depreciation

Two more additional points of interest we encountered at the PTI Farm are the following:

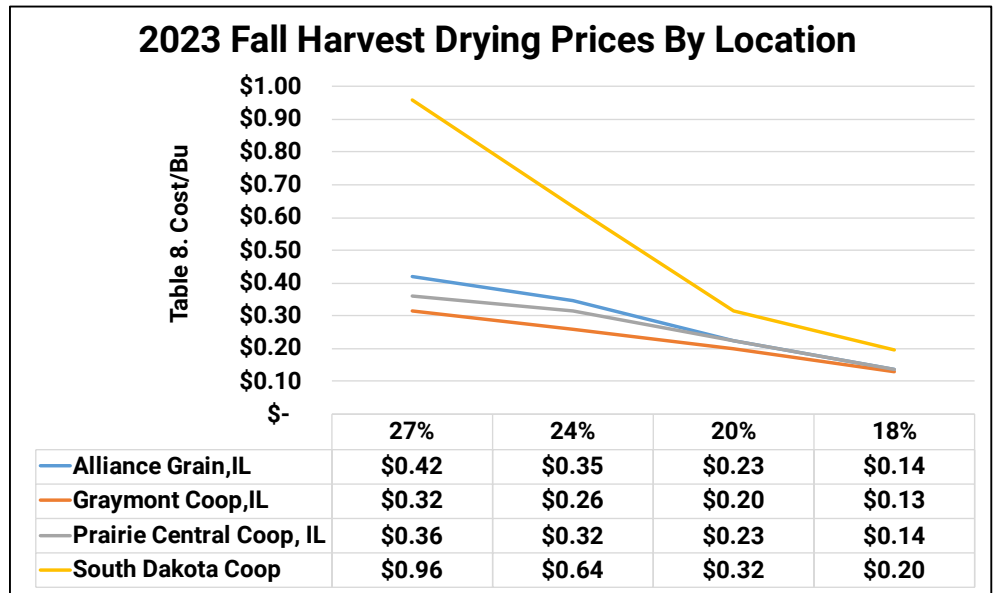
- ✓ **Advantage of 24Hr Grain Delivery:** Although it is unknown how to place a numerical dollar value at this point at this time, but efficiency of harvest clearly was improved. The fact that harvest could continue “after hours” did speed harvest up which allowed for other activities such as tillage and cover crop planting.

- ✓ **Patronage Dividends:** Patronage dividends are distributions of profits paid by a co-operative to growers. Patronage dividends are paid based on a portion of the profit the business makes. The exact dividend each member receives is based on how much they used the co-op's services or how much in products they purchased. In this case, proceeds for grain drying need to be factored into this feasible study where growers would have access to potential patronage payments. For example, the local cooperative near the PTI Farm has paid patronage on drying expenses averaging 21.85% annually over the past 5 years. Using the same factors discussed in this study, a patronage dividend of \$12.11/A. would be paid to the grower. This dividend would then bring total savings of the grain storage facility to +\$75.06/A., thus years to return on investment at 8.8 years.

On-Farm Drying and Storage Study

Another interesting finding with this project is the fact that commercial drying rates are quite different in various parts of the country. At the PTI Farm, we enjoy the fact that we have much lower drying costs than in other parts of the country.

Table 8. illustrates commercial drying rates of corn at three local Illinois grain terminals near the PTI Farm, compared to a Northwestern US grain cooperative located in South Dakota. These drying rates are near +3X at 27%, + 2.5X at 24%, +1.6X at 20%, and +1.5X at 18% to that of local grain terminal commercial drying rates near the PTI Farm in Pontiac, IL.



This increase in commercial drying cost changes the economics and value-based approach to a farmer considering building a grain storage and drying facility.

Table 9. Commercial Grain Drying Rates South Dakota

Moisture	Drying Cost	Total Cost	PTI On-Farm Cost
27%	\$0.96/Bu.	\$230.40/A.	\$43.20/A.
24%	\$0.64/Bu.	\$153.60/A.	\$32.40/A.
20%	\$0.32/Bu.	\$76.80/A.	\$18.00/A.
18%	\$0.20/Bu.	\$48.00/A.	\$10.80/A.

Table 9. summarizes the cost of drying corn with commercial South Dakota rates versus the cost of Fall 2023 on-farm drying at the PTI Farm. In this scenario, South Dakota commercial drying rates resulted in additional drying costs of +5.3X at 27% corn, +2.5X cost at 24% corn, +1.6X at 20% and +1.5X at 18% corn.

On-Farm Drying and Storage Study

If we recalculate the numbers to factor in the higher cost of drying in this example, it vastly changes the return on investment of the grain storage and drying facility. The table below illustrates the cost analysis of a grower drying and storing grain using these higher cost parameters.

2023 GSI Grain Storage and Drying Study: South Dakota Rates	
1. Cost of Drying Corn	+\$99.60
2. Corn Shrink Reduction	+ \$2.94
3. Phantom Yield Loss Reduction	+ \$5.96
4. Seasonal Price Difference/Premiums	+\$49.56
Total Savings	+\$158.06
Total Investment:	\$1,000,000
Total Investment by Acre:	\$ 666.70
Years to Break-Even on Investment:	4.2 Years*
<small>*No calculated Depreciation</small>	

- The savings of drying corn alone contribute +\$99.60/A., which would be a +\$70.80/A. improvement over Illinois PTI Farm on-farm drying advantages.
- Shrink savings contribute an additional +\$2.94/A. using a 14.5% shrink factor.
- Phantom yield loss reduction would provide a gain of +\$5.92/A. It is interesting to note that without an on-farm drying system, these gains would be negated by the high cost of drying at higher moisture levels. Using commercial drying costs, 18% corn would be economic optimum harvest moisture, while 20% would cost **-\$5.57/A.**, 24% at **-\$64.27/A.** and 27% at **-\$135.14/A.**
- For this example, the same carry in the market gains of +\$49.56/A. apply.
- Total savings of the entire grain drying and storage system tally +\$158.06/A., which would provide a return on investment of just under +24%, compared to +13% at the PTI Farm Illinois location.
- Net pay-off or break-even would occur at 4.2 crop seasons, compared to 7.6 years at the PTI Farm Illinois location.

Corn Tillage Study

Objective: To evaluate the yield and economic impacts of various tillage programs in a corn after soybean rotation. Tillage programs include conventional till, strip-till, vertical till, no-till and in-line rip.

Figure 1. KUHN® Krause Gladiator®



Figure 2. Sunflower® 4630 Disc Ripper



Corn Tillage Study Continued

Figure 6. Univ. of IL Machinery Cost Estimates

Tillage Practice	Category	Cost
Conventional Till	Ripper	\$36.40
	Soil Finisher	\$14.60
	Plant	\$21.40
	Total:	\$72.40
Strip Till	Strip	\$25.90
	Burndown	\$10.00
	Plant	\$21.40
	Total:	\$57.30
Vertical Till	Vertical	\$17.60
	Burndown	\$10.00
	Plant	\$21.40
	Total:	\$49.00
No Till	Plant	\$21.40
	Burndown	\$10.00
	Total:	\$31.40
In-Line Ripper	V-Ripper	\$33.70
	Soil Finisher	\$14.60
	Plant	\$21.40
	Total:	\$69.70

Figure 4. Planting in No-Till



Figure 1. Kuhn® EXCELERATOR® XT 8010 Vertical Tillage



Figure 5. Sunflower® 4608 In-Line Ripper



Corn Tillage Study Continued

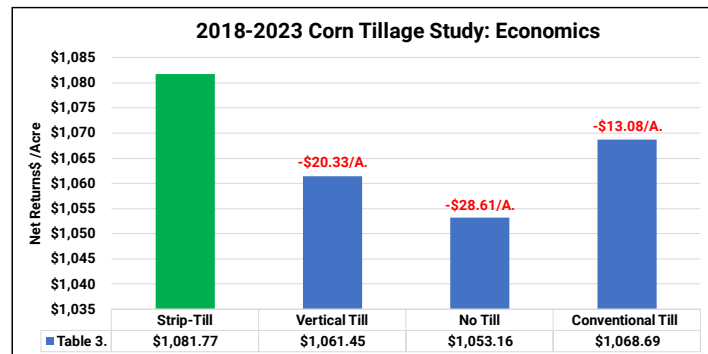
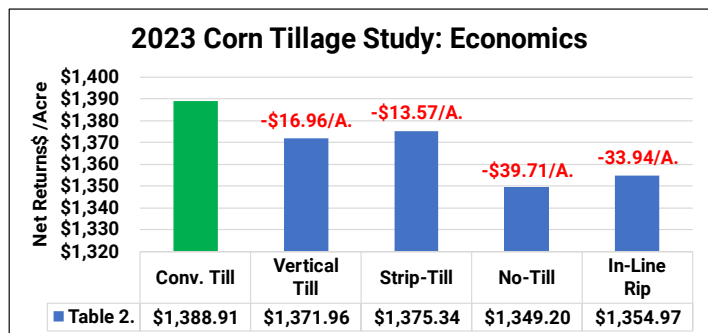
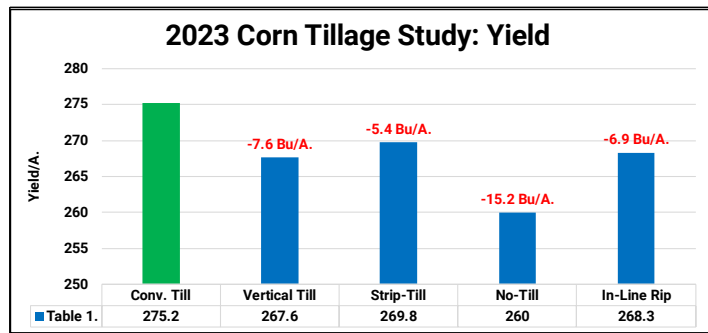
Results: To understand both yield and economics, the University of Illinois Machinery Cost Estimate Summary is used to calculate individual cost of each tillage program (Figure 6). For the three reduced tillage programs, an \$10/A. burn-down is also included.

Tables 1-2. illustrates yield and economics for each tillage segment.

After applying all appropriate costs to each individual tillage program, conventional till offered the highest overall yield and revenue in this tillage system study.

Compared to conventional tillage, strip-till offered losses of **-5.4 Bu/A.** and **-\$13.57/A.**, vertical tillage **-7.6 Bu/A.** and **-\$16.96/A.**, in-line ripping losses of **-6.9 Bu/A.** and **-\$33.94/A.** and finally no-till at **-15.2 Bu/A.** and **-\$39.71/A.**

Table 3. illustrates multi-year data from the PTI Farm from 2018-2023. Strip-till over this time period has provided the highest overall net returns, with conventional till behind by **-\$13.08/A.** Vertical and no-till have resulted in losses of **-\$20.33** and **-\$28.61/A.** respectively.



Summers Variable Rate Tillage™ Study

Objective: To evaluate the yield and economic benefit of implementing a single pass vertical tillage (Figure 1.) program compared to a single pass soil finisher (Figure 2).

The VRT Renegade® is an all in one tillage tool. It has the ability to run true vertical tillage, but also has the ability for more aggressive tillage. This is all done with iControl™ implement technology. Every system on the bar is controlled with an iPad allowing you to make on the move adjustments to get the perfect implement setup.

Results: Yield only varied 0.7 Bu/A. between the two tillage implements. Using University of Illinois Machinery Cost Estimates (Figure 3.), the soil finisher proved economic gains of +\$6.72/A.

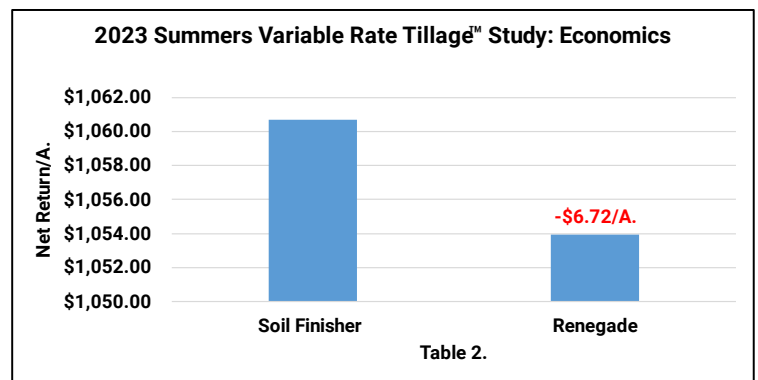
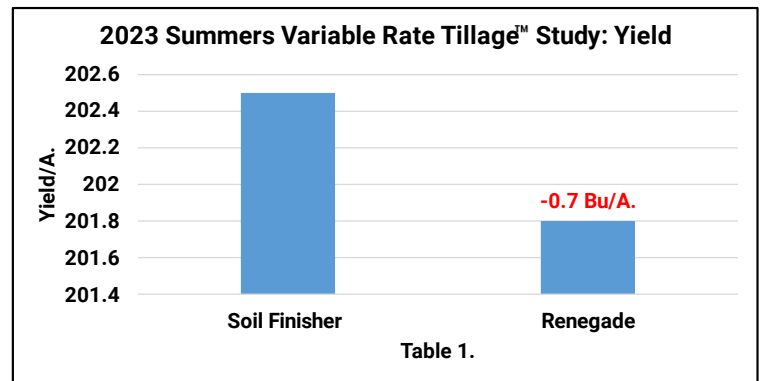
Tillage Practice	Category	Cost
Conventional Till	Ripper	\$ 36.40
	Soil Finisher	\$ 14.60
	Plant	\$ 21.40
	Total:	\$ 72.40
Strip Till	Strip	\$ 25.90
	Burndown	\$ 10.00
	Plant	\$ 21.40
	Total:	\$ 57.30
Vertical Till	Vertical	\$ 17.60
	Burndown	\$ 10.00
	Plant	\$ 21.40
	Total:	\$ 49.00
No Till	Burndown	\$ 10.00
	Plant	\$ 21.40
	Total:	\$ 31.40

Figure 3. Univ. of IL Machinery Cost Estimates

Figure 1. Summers VRT Renegade® Vertical Tillage



Figure 2. Sunflower® 6333 Land Finisher



Yetter Strip Freshener™ Study

Objective: To evaluate Yetter 2984 strip fresheners to facilitate consistent soil warming and bring existing strips to life. Original fall strips made in October after harvest were freshened in April before planting (Figure 1).

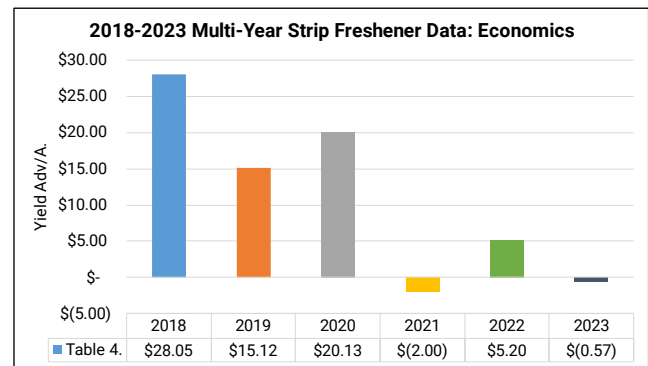
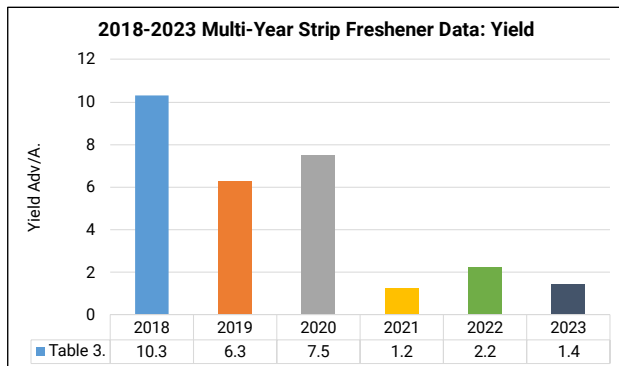
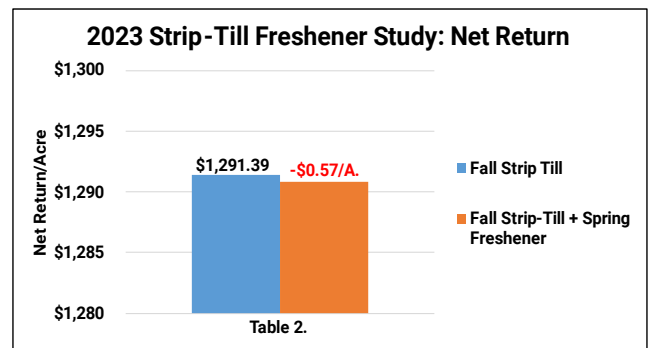
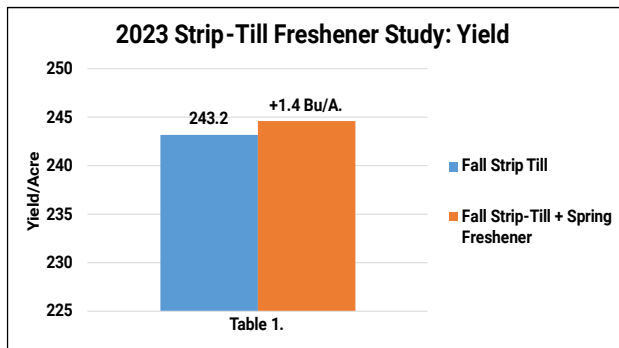


Figure 1. Yetter 2984 Strip Freshener™

Features:

- 3-blade arrangement with rolling basket to condition strips
- Operates at 6 to 10 mph and 1 1/2" to 4" deep, depending on depth setting.
- Precision Planting CleanSweep® residue managers to clean rows while building strip.

Results: Spring strip freshening increased yield by +1.4 Bu/A. and resulted in economic losses of **-\$0.57/A.**, using a custom cost of \$8/A. for calculating charge of application (Tables 1-2.) Tables 3-4. illustrate multi-year 2018-2023 average yield gains of +4.8 Bu/A. with net positive economic gains of +\$10.99/A. Only two years in six were net losses associated from freshening strips.



Planting Date: May 11th Hybrid: Wyffels 7208RIB Population: 34K Row Width: 30" Rotation: CAB Corn Price: \$5.31

Soybean Table of Contents:

Soybean Planting Principles:

Planting Date	180
Multi-Year Early Plant Date	181
Soybean Early Plant Maturity	182
Starter Fertilizer Response by Date	183-184
SmartDepth® Planting Depth	185-187
Reveal® Residue Management	188-190
Downforce Management	191-193
Keeton® Seed Firmer	194
Singulation	195
SeedRight Bundle Drop Singulation	196
High Speed	197
Tillage/Closing Wheels	198-200
Planting Direction	201
REVLIN® HOPPER THROTTLE®	202
Cover Crop Study	203-205
Rolling	243
Strip Cropping	244-249
Strip Cropping System Summary	250
Chopping Corn Head	261

Soybean Dry Fertilizer Studies:

Broadcast vs Banding	206-207
Broadcast vs Banding Rate Efficiency	208-210
Liquid vs Dry Fall Strip-Till	211-213
Calcium Products 98G®	214

Soybean FurrowJet® Programs:

Aqua-Yield® NanoCS®	234-235
Nachurs Tripple Option	236
Xyway® LFR®	237-238
Zironar™	239-240
FurrowJet® Side-Wall	241

Soybean Foliar Programs:

Revytek™ Foliar Fungicide	251
Miravis® Neo™ Foliar Fungicide	252
Ground vs UAV	253-254
Aqua-Yield® NanoPack®	255-256

Soybean Conceal® Programs:

Marco Fertilizer Conceal® 14-12-4-6S	233
--------------------------------------	-----

Soybean Tillage Studies:

Soybean Tillage	257-259
Pre-Strip Vertical Tillage	260

Soybean Intensive Mgt. Studies:

NETAFIM™ Irrigation Study	215
Soybean Seed Size	216
High Management Nachurs®	217-218
High Management AgroLiquid®	219-222
Irrigated vs Dryland ROI Analysis	223
High Management Marco	224-225
High Management Stoller® USA	226-227
High Management NewFields Ag/ NMS-	228-229
High Management Ocean Blue Ag	230-232

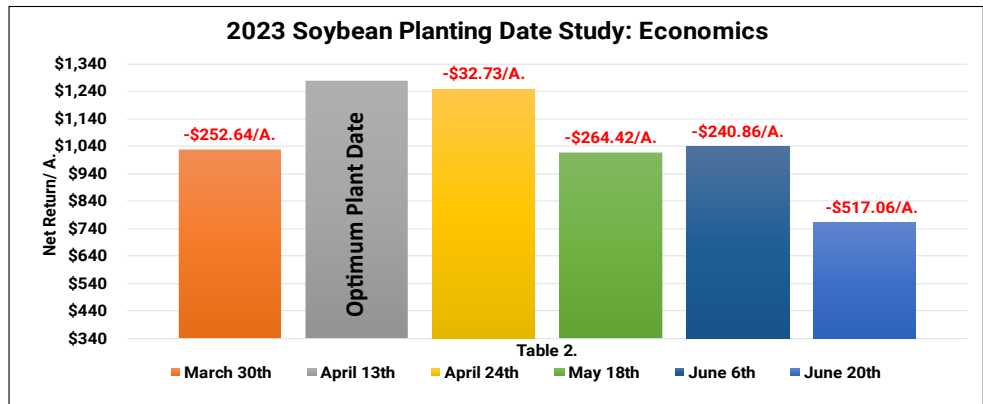
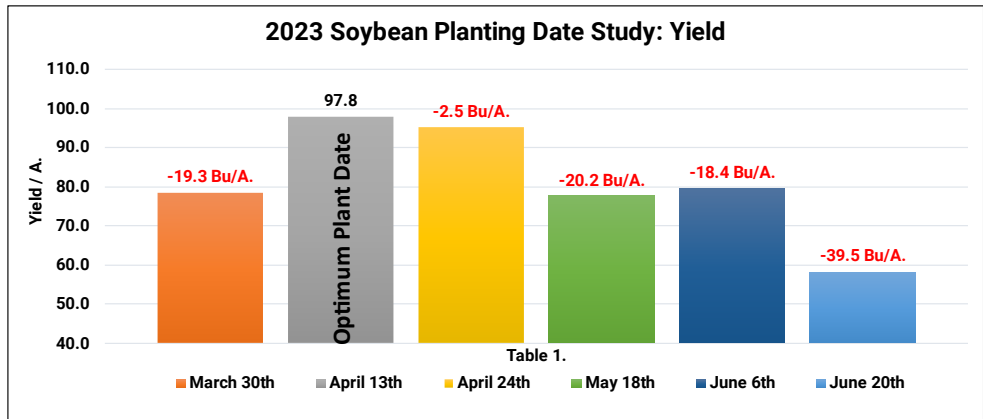
Soybean Planting Date Study

Objective: To evaluate various soybean planting dates throughout the spring to determine optimum planting date. Once optimum yield is discovered, data can then be analyzed to determine the deviation of yield at both early and late planting dates compared to traditional norms. With the recent trend of earlier soybean planting dates achieving higher yields, it is our intention to plant as early as possible in this study and plant every week throughout the spring planting season when fit.

Results: Table 1. illustrates the results of five planting dates over March 30th, April 13th, April 24th, May 18th, June 6th and June 20th. Optimum planting date occurred on April 13th, receiving the highest yield of 97.8 Bu/A.

Early March 30th plantings fell short by **-19.3 Bu/A.** mainly due to frost damage. The April 24th planting date realized minimal yield loss of **-2.5 Bu/A.**

Bu/A., with economic losses of **-\$32.73/A.** However, May 18th and June 6th planting dates started the large decrease in yield, with losses of **-20.2 Bu/A.** to **-18.4 Bu/A.** and corresponded to losses of **-\$264.42/A.** and **-\$240.86/A.** June 20th plantings, which would simulate double crop soybean after wheat planting incurred the largest yield decrease of **-39.5 Bu/A.** resulting in economic losses of **-\$517.06/A.**



Multi-Year Early Plant Date Soybean Study:

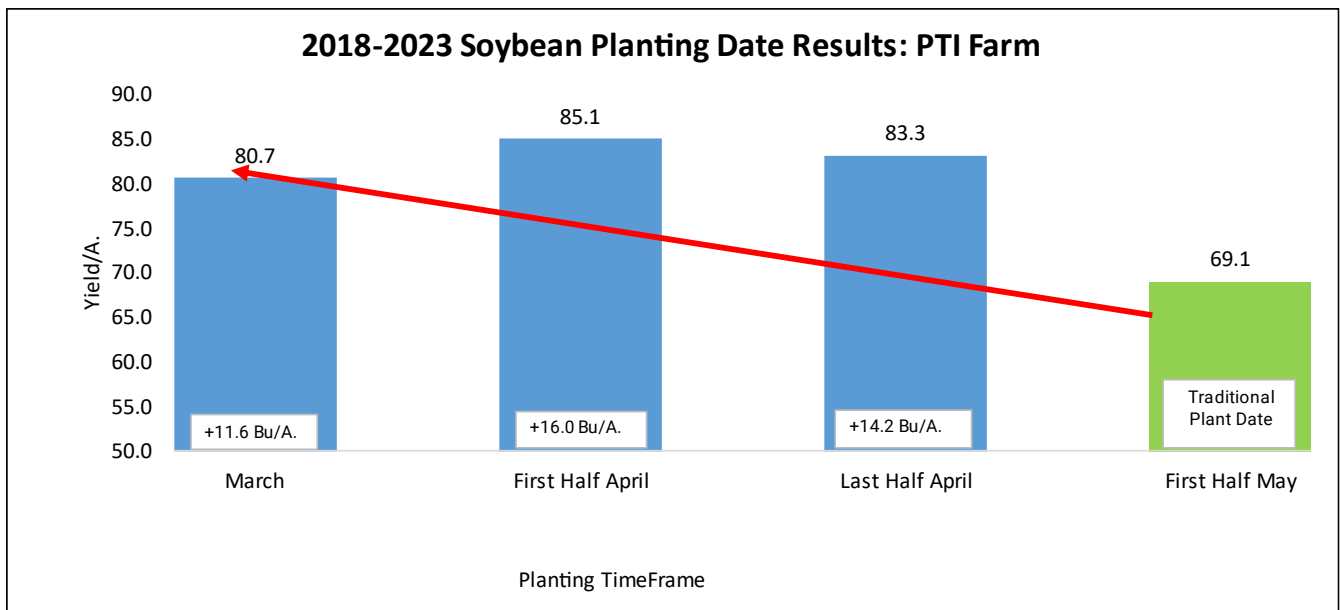
Objective: To evaluate the yield and economics of early planted soybeans compared to traditional later soybean plant dates. Pushing planting dates earlier; extends the growing season, leading to earlier flowering dates, and overall higher yield potential.

Results: The table below illustrates multi-year early planted soybean data from the PTI Farm. Traditionally, planting dates during the first week of May is very common for soybeans. However, multi-year data from 2018-2023 has proven earlier planting can result in significant yield increases.



Ultra-early planting dates in March have accomplished +11.6 Bu/A. yield gains compared to that of traditional planting dates in the first week of May. As planting dates were made in either the first half or second half of April, yield gains of +14.2 Bu/A. to +16.0 Bu/A. were observed.

In general, PTI data suggests that if a grower is capable of moving planting dates earlier, increased yield is obtainable if managed correctly.



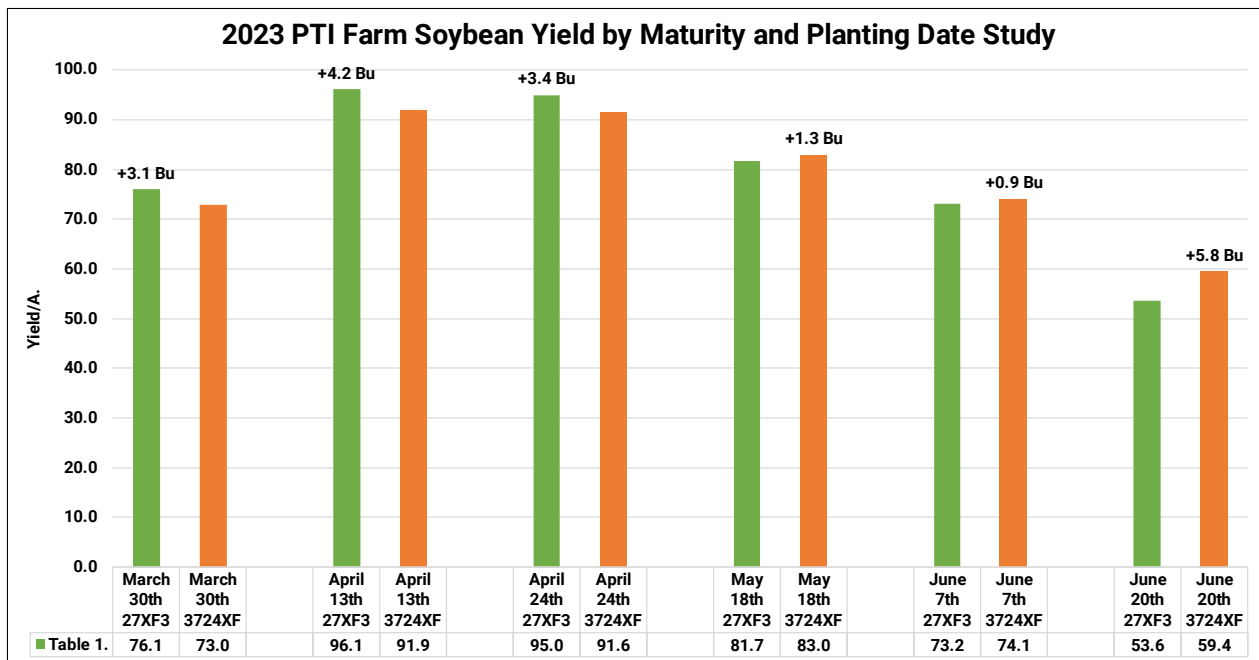
Soybean Early Plant Maturity Study

Objective: With the recent trend of earlier soybean planting dates achieving higher yields, it poses the question “If I plant soybeans early, should I plant an earlier or later maturing soybean?” This study evaluates the difference in yield on a group 2.7 and 3.7 maturity soybean planted on March 30th, April 13th, April 24th, May 18th, June 7th, and June 20th.

Results: Table 1. illustrates the 2.7 maturity soybean outperformed the later 3.7 by +3.1 Bu/A. to +4.2 Bu/A. in March and April. Once we get later in the year in May and June the later 3.7 maturity soybean out-performed the earlier 2.7 by +0.9 Bu/A. to +5.8 Bu/A.



As only a 2nd year study in 2023, we plan to continue evaluating this on an annual basis going forward to help understand more regarding soybean maturity by planting date.



Planting Date: Varied Variety: Golden Harvest® 3724XF, Asgrow 27XF3 Population: 120K Row Width: 30" Rotation: BAC SB Price: \$13.09

Soybean Starter Fertilizer Response by Planting Date Study

Objective: To monitor the performance of starter fertilizer at various planting dates. When does starter fertilizer give the highest returns? Does starter fertilizer respond differently at earlier planted dates versus later? In this study we evaluate five planting dates consisting of March 30th, April 13th, April 24th, May 18th, and June 6th with and without a starter fertilizer, monitoring its performance throughout the planting season.

The starter fertilizer program used for this study consists of the following:

<u>Product</u>	<u>Fertilizer Analysis</u>	<u>Placement of Fertilizer</u>
1 Gal/A. Triple Option®	4-13-17-1S	FurrowJet® Center
2 Gal/A. Triple Option®	4-13-17-1S	FurrowJet® Wings
3 Gal/A. K-Fuse®	6-0-12-12	Conceal®
5 Gal/A. Nachurs Throwback®	9-27-4-4	Conceal®

Figure 1. FurrowJet® Placement

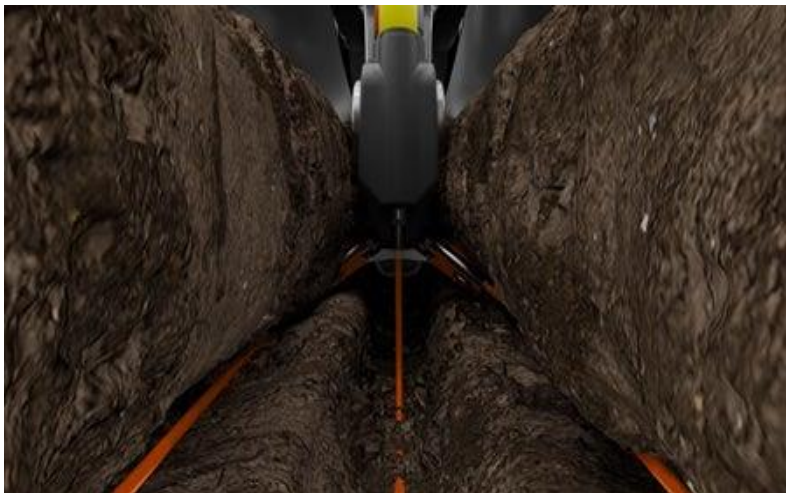


Figure 2. Conceal® Placement



Soybean Starter Fertilizer Response by Planting Date Study Continued

Results: Table 1. illustrates all starter fertilizer treatments offered minimal yield gains at each of the five planting dates. Yield gains averaged +6.4 Bu/A., ranging from **-1.5** to +9.5 Bu/A. between all the planting dates. 2023 starter fertilizer treatments offered the highest yield gains in the April 13th and May 18th plantings with yield gains of +9.5 Bu/A. As planting dates progressed later May 18th, yield gains fell to **-1.5 Bu/A.**

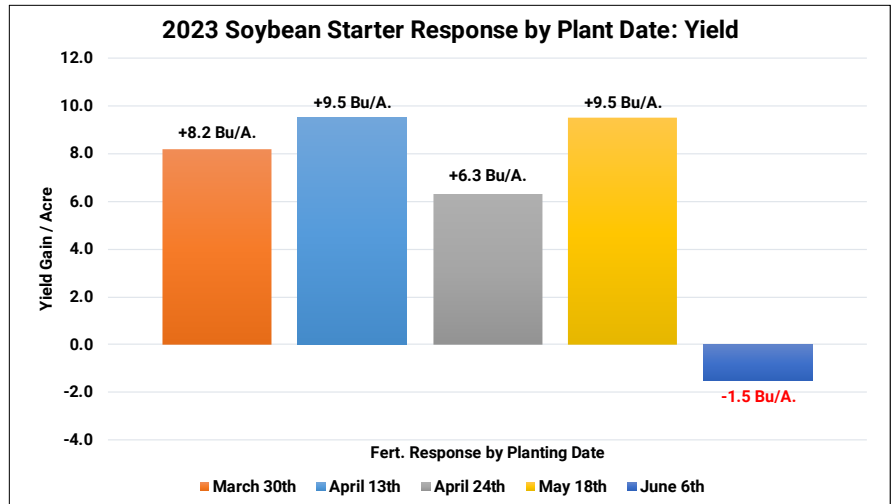
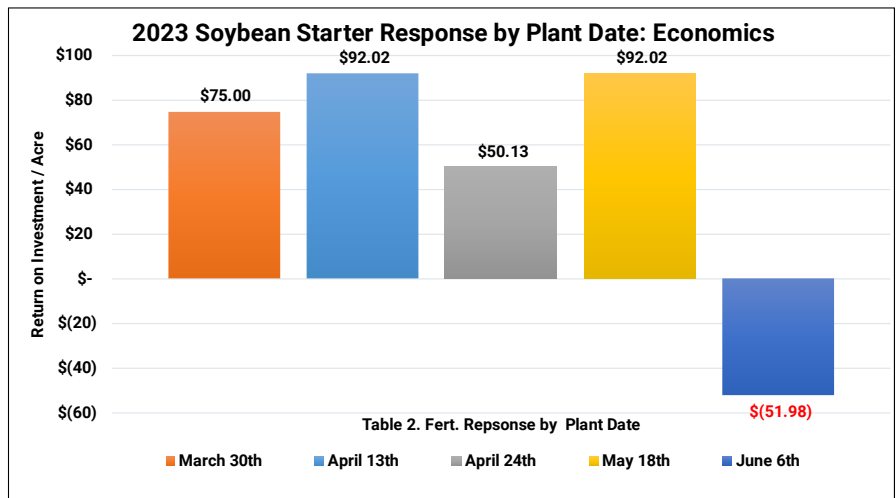


Table 2. focuses on net return on investment and illustrates that all typical planting dates of starter fertilizer treatments realized net gains ranging from +50.13/A. to +\$92.02/A.



The late, June 6th planting date realized net losses of **-\$51.98/A.** due to loss of yield when planting that late.

Planting Date: Varied Variety: GH3724XF Population: 130K Row Width: 30" Rotation: BAC SB Price: \$13.09

K-fuse®: \$5.70/Gal Nachurs Throwback: \$4.80/Gal Triple Option: \$7.08/Gal \$30 Fertilizer Reallocation

SmartDepth® Soybean Planting Depth Study

Objective: To evaluate yield and economic performance of various manual soybean planting depths consisting of 1" to 2.75" in ¼" increments, compared to automated variable depth planting using SmartDepth® control.

Digging seeds is a time consuming yet important task at planting time (Figure 1). Getting your eyes on the furrow where the seeds are placed, will allow you to understand if those seeds are in an environment to thrive. Is the seed being planted into adequate moisture? Until now, we didn't know this for every seed, and we were unfortunately simply guessing.

Figure 1. Seed Furrow



With a SmartFirmer® sensor (Figure 2.) you can now have virtual eyes in the furrow. Soil moisture is a critical component for seed germination, uniform plant emergence, and ultimately crop yield. SmartFirmer® sensors gives row-by-row visibility to soil moisture in the seed furrow, allowing farmers to choose the right planting depth as soil conditions change. Currently, the recommendation for ideal furrow moisture levels to achieve adequate soybean emergence, is near 32%. Using the 20|20® monitor (Figure 3.) in tandem with SmartFirmer® sensors, we now have the ability to evaluate furrow moisture in real-time. Based on this real-time information, growers can make decisions based on live sensing data.



Figure 3. 20|20® Monitor System



Figure 2. SmartFirmer® Sensor

SmartDepth® Soybean Planting Depth Study

Figure 4. illustrates SmartDepth®, a unique product that takes the technology one additional step further, allowing planting depth to be changed on a planter, by section or individual row basis. This can be done manually from the tractor cab and 20|20® console, or automatically using furrow moisture values from SmartFirmer® sensors. Growers can customize their own settings to optimize both furrow moisture and planting depth values (Figure 5). This control allows growers to measure, react, and take control of planting depth to optimize emergence timing.

Figure 5. SmartDepth® Customization Screen



Figure 4. SmartDepth® Control System

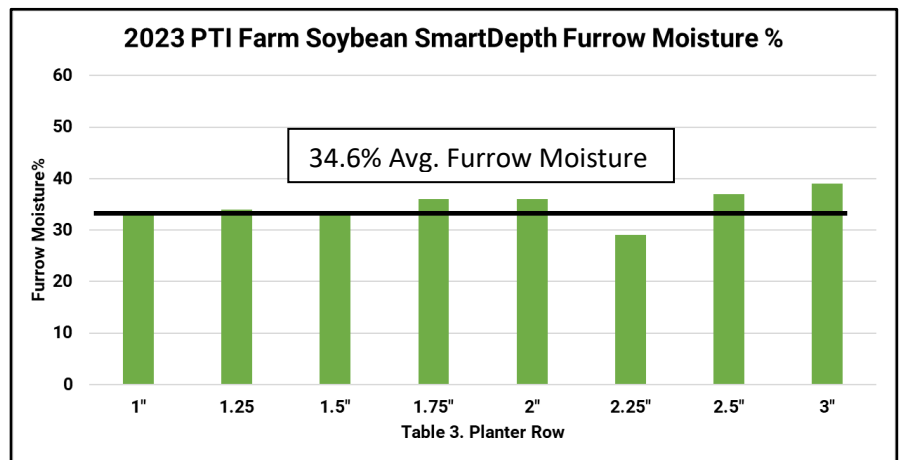
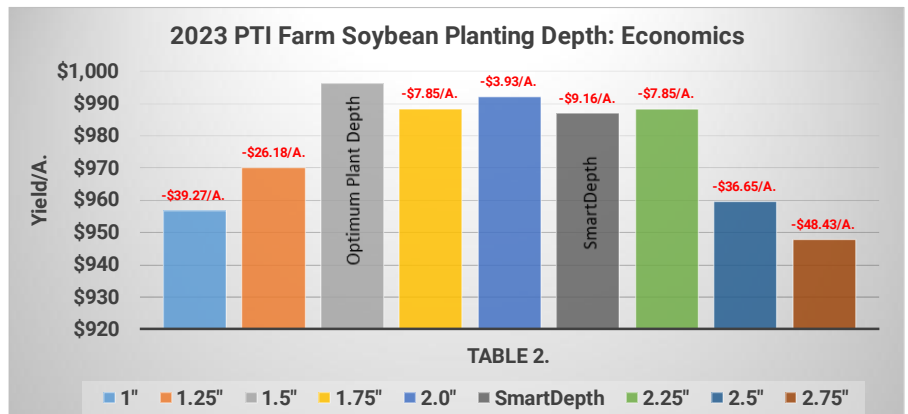
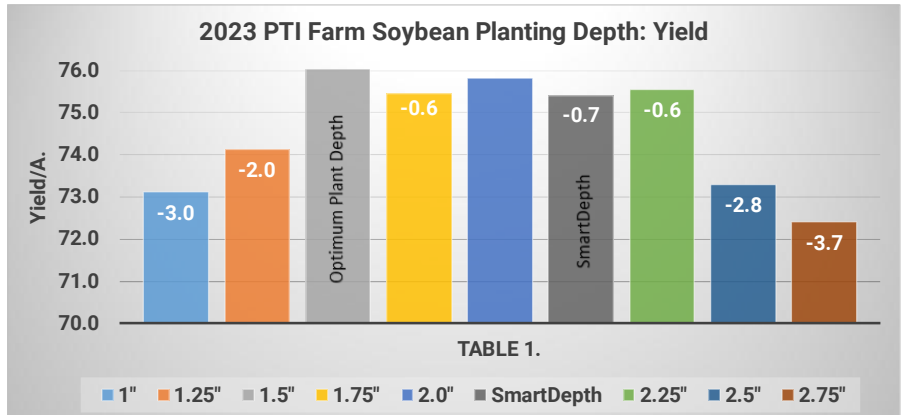


SmartDepth® Soybean Planting Depth Study

Results: Tables 1-2. reveal that SmartDepth® did not offer the highest yield in the study, but did obtain yield within 0.7 Bu/A. and \$9.16/A. compared to that of optimum planting depth.

Table 3. illustrates average furrow moisture of 34.6% across all planter rows when SmartDepth® was implemented to obtain ideal planting depth into moisture. Currently, the recommendation for ideal furrow moisture levels to achieve adequate soybean emergence, is near 32%.

More work needs to be done to understand how to continually customize settings to achieve proper planting depth automatically. However, it does appear that by using SmartDepth®, SmartFirmer® and a 20|20® monitor system, growers can measure and chase the furrow moisture line and adjust planting depths as they deem appropriate.



Reveal® Residue Management Study

Objective: This study evaluates the yield and economic benefit of Reveal® frame mounted row cleaners in a soybean after corn conventional tillage environment.

Residue management is a necessary part of today's operation to maximize profitability. Tougher stalks and more corn-on-corn acres mean a heavier load of residue that needs to be controlled. Residue in the seed trench competes with seedlings for moisture and can harbor diseases.

Reveal® (Figure 1-2.) is frame mounted, so unlike other row cleaners it gets rid of that row unit chatter. It has a gauge wheel that precisely controls the depth of the cleaning tines. It also has an airbag that makes sure the depth that it's set at, stays consistent. The pressure of the airbag can be controlled on the 20|20® monitor (Figure 3).

In this agronomic study, Reveal® is compared to the absence of row cleaners at 10, 20, 30 and 40 PSI Notch 1 down settings:

Figure 1. Reveal® System



Figure 3. 20|20® System

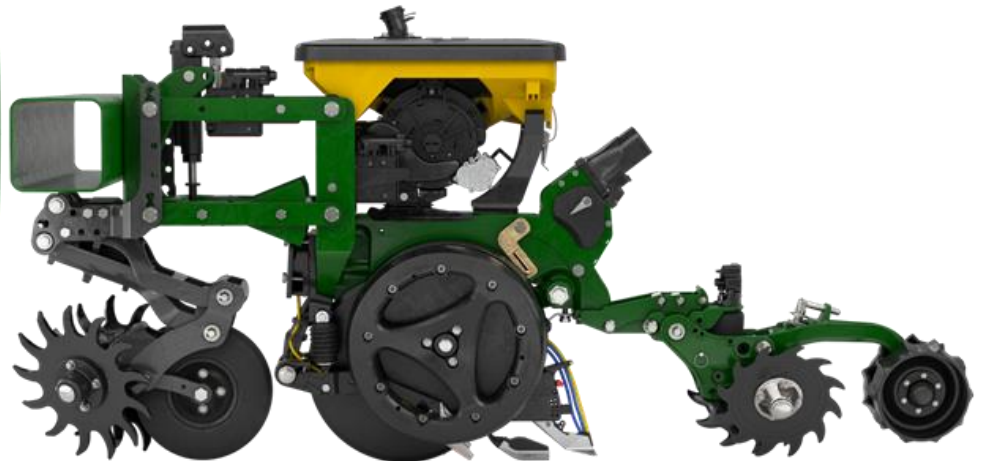


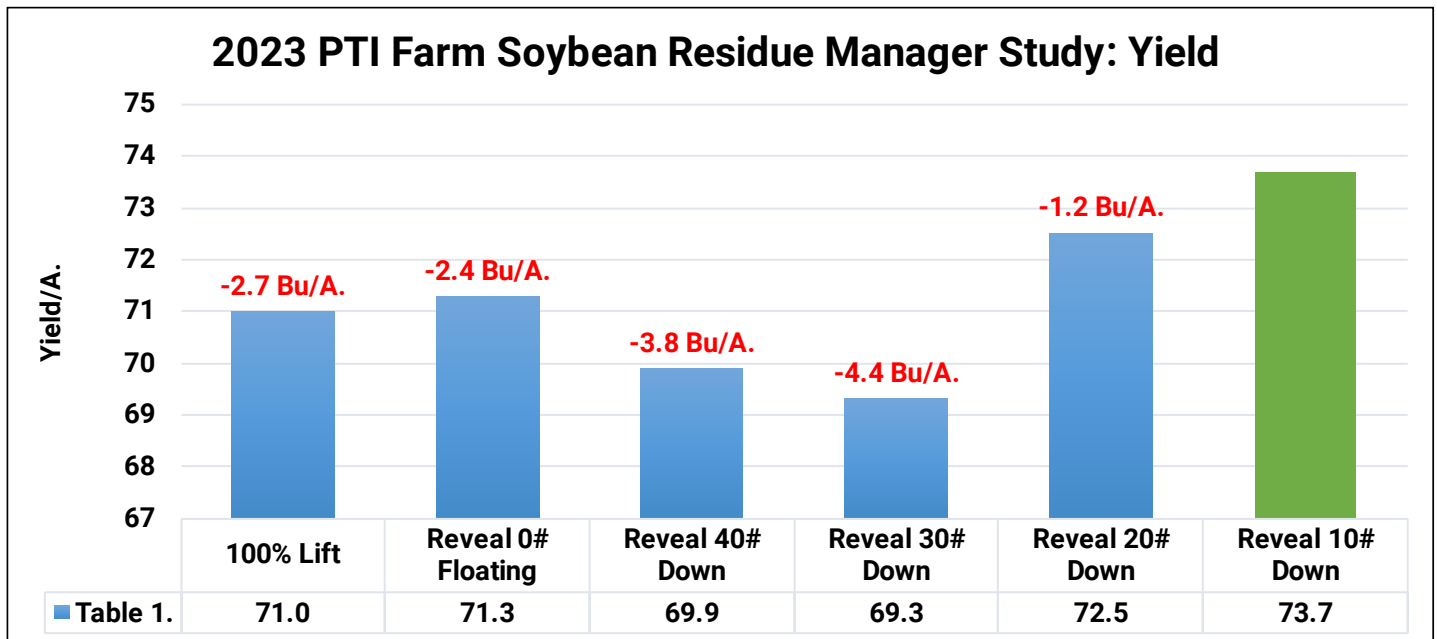
Figure 2. Reveal® System

Reveal® Residue Management Study Continued

Results: Table 1. illustrates the Reveal® residue management system resulted in positive yield gains in some settings, averaging +0.34 Bu/A. compared to the absence of row cleaners. Yield response varied from **-1.2** to +2.7 Bu/A. with 10 PSI settings proving highest yield at +2.7 Bu/A. gains.



Residue management in the furrow is crucial for optimum yield and highest revenue potential. At \$13.09/Bu. soybeans, a yield gain of +2.7 Bu/A. when using the correct setting would result in increased farm revenue of \$35.34/A. and proves to be a core principle of planting that a grower should not overlook.

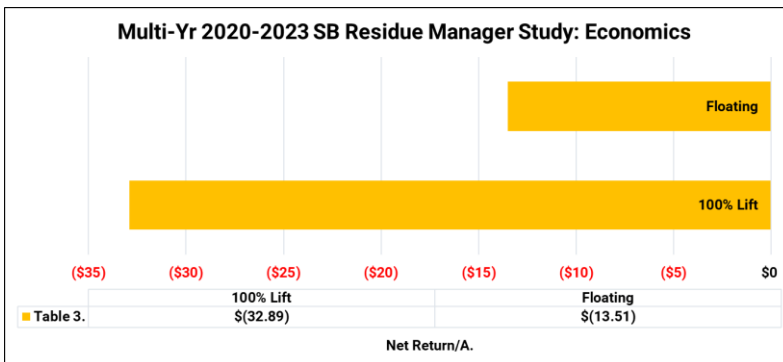
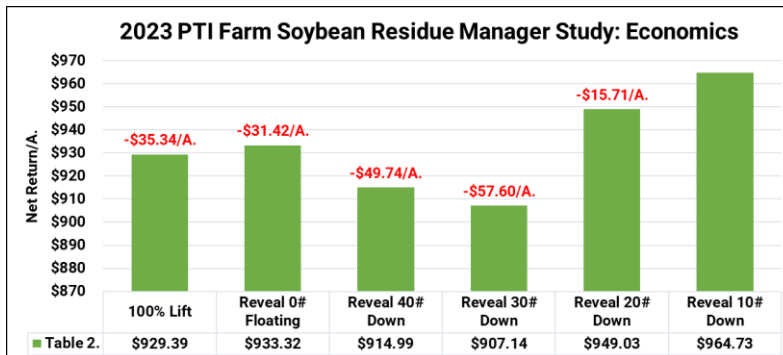


Reveal® Residue Management Study Continued

Results: Table 2. illustrates the Reveal® residue management system set at 10 PSI resulted in positive yield gains in all settings, averaging + 2.96 Bu/A. When running no residue management system there was a loss of **-2.7 Bu/A.** resulting in a economic loss of **-\$35.34/A.** Running a residue management system in the floating position resulted in an economic loss of **-\$31.42/A.** Table 2. also shows that when running your residue management system on to heavy of a setting it can have a drastic impact causing losses from **-\$15.71/A.** to **-\$57.60/A.**



Table 3. Illustrates multi-year data comparing no residue managers and floating residue managers to Reveal set at 20 PSI down. Over the past three years 20 PSI had a economic advantage of +32.89/A. over no residue management system and +13.51/A. over a floating residue management system.



DownForce Management Study

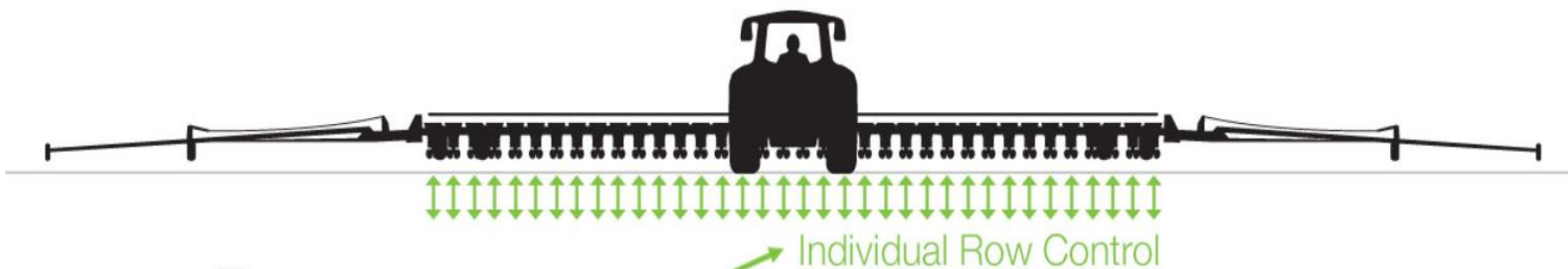
Objective: This soybean study evaluates yield impact of implementing proper downforce compared to too light or too heavy row unit settings. Planter row unit downforce is a common agronomic issue that often goes unaddressed. When downforce matches field conditions, the depth of planting is consistent and correct. Too light of row unit downforce causes planting depth to shallow up, potentially placing seed in dry soil, creating poorly rooted plants that struggle for water and nutrients. Conversely, too much downforce can lead to furrow side-wall compaction, also creating an environment that can cause limited plant access to water and nutrients.

DeltaForce® system replaces the springs or air bags on your planter with hydraulic cylinders (Figure 1). It automatically increases or decreases weight with military precision, on each row individually. When one row encounters conditions different than another (wheel tracks, old roadbeds, clay knobs, headlands, etc.), each will adjust independently (Figure 2). Row by row, foot by foot, even seed by seed an environment that fosters uniform germination, optimum growth and maximum yield can be produced.

Figure 1. DeltaForce® Cylinder



Figure 2.

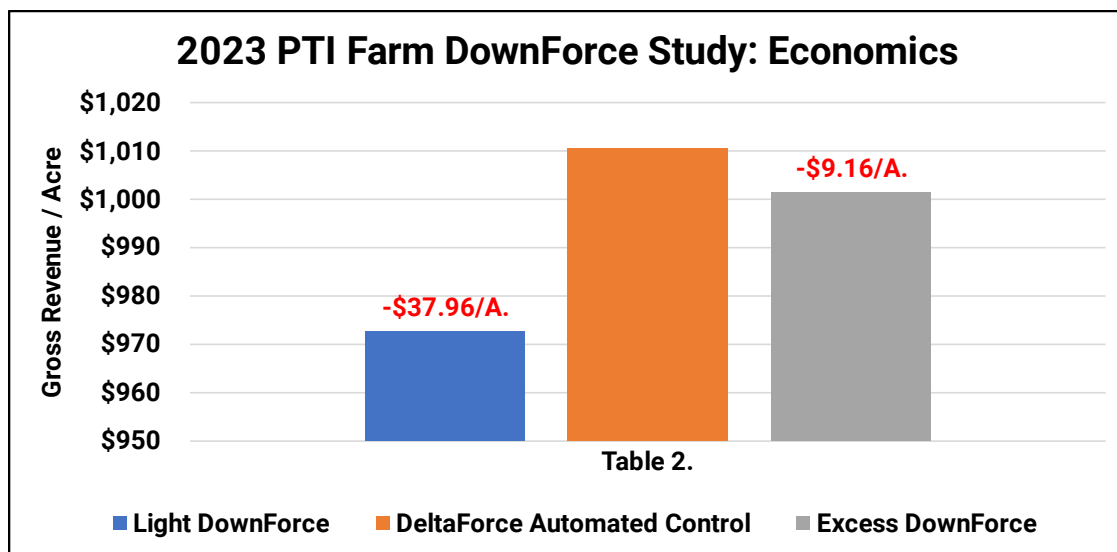
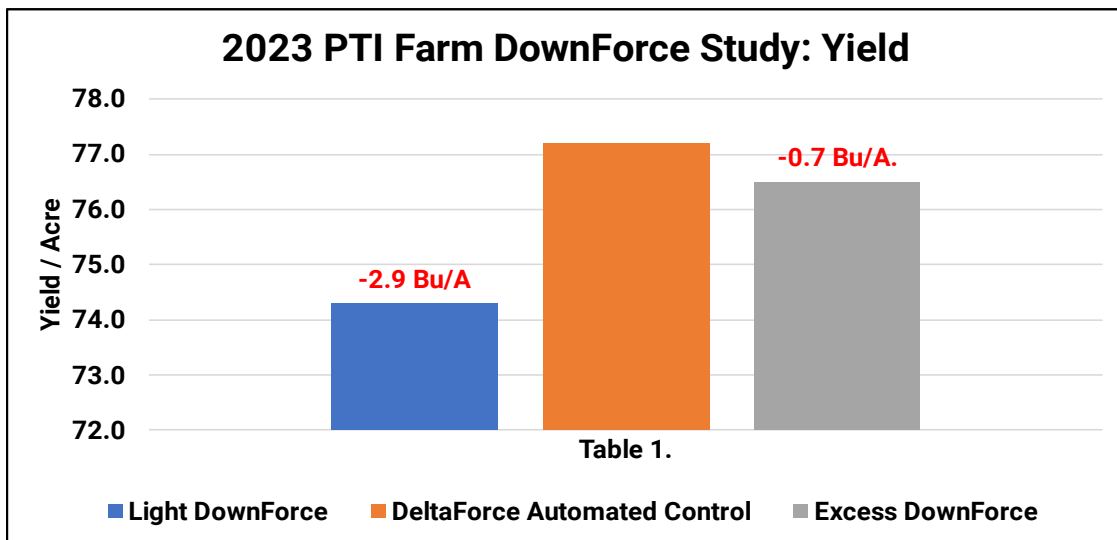


DownForce Management Study Continued

Results: Tables 1-2. illustrates the yield and economic response of DeltaForce® automated control compared to excessive and light downforce settings. Settings for this study include;

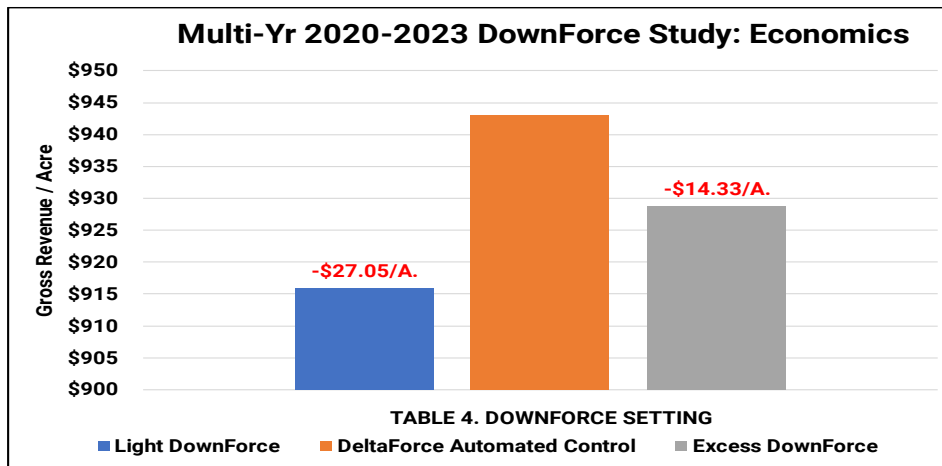
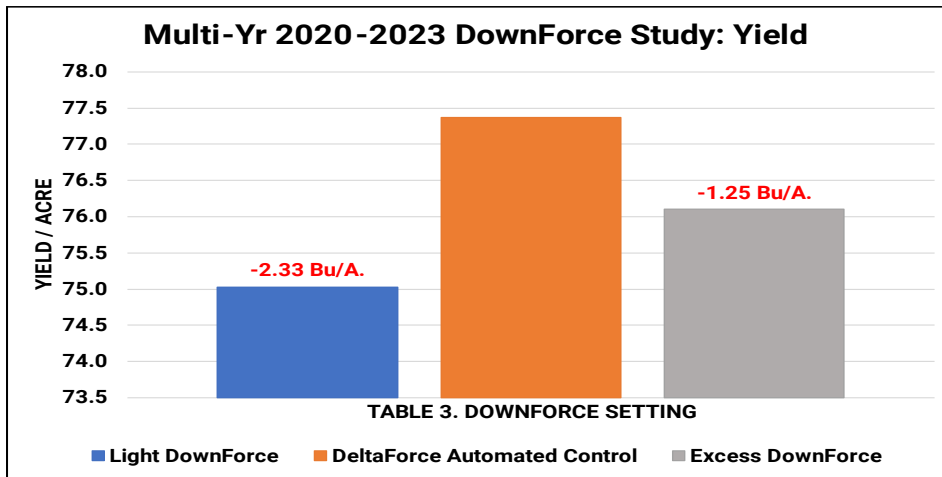
- Too light of Downforce (175# lift, 100# down)
- Proper Downforce (Automated Custom 90#)
- Excess Downforce (550# down, 100# up)

2023 data resulted with light downforce realizing yield losses of **-2.9 Bu/A.**, with corresponding net economic losses of **-\$37.96/A.** Heavy downforce caused yield losses of **-0.7 Bu/A.**, with economic losses of **-\$9.16/A.**



DownForce Management Study Continued

Tables 3-4. illustrate multi-year data which resulted in light downforce having yield losses of **-2.33 Bu/A.**, with corresponding net economic losses of **-\$27.05/A.** Heavy downforce caused yield losses of **-1.25 Bu/A.**, with economic losses of **-\$14.33/A.**



Planting Date: May 5th Variety: Asgrow 35XF3 Population: 130K Row Width: 30" Rotation: BAC Soybean Price: \$13.09

Keeton® Seed Firmer Study

Objective: This study evaluates the benefits of Keeton® Seed Firmers (Figure 1). Seeds don't always land right in the bottom of the trench where they belong. With its unique, in-the-trench design, the Keeton® Seed Firmer gently firms those seeds to the bottom of the V-trench (Figure 1). The end result is even depth, correct seed-to-soil contact, and most importantly uniform germination.

Results: The table below illustrates multi-year data over the time period of 2020-2023 where Keeton® Seed Firmers resulting in yield gains of +1.4, +0.7, +0.9, and +0.9 Bu/A. Using average soybean prices for each individual year, Keeton® Seed Firmers resulted in average economic gains of +\$10.08/A.

At a cost of \$40/row for Keeton® Seed Firmers and quick attach brackets for a 16-row planter, using the +\$10.08/A. increase in revenue, break-even occurs at only 64 acres.

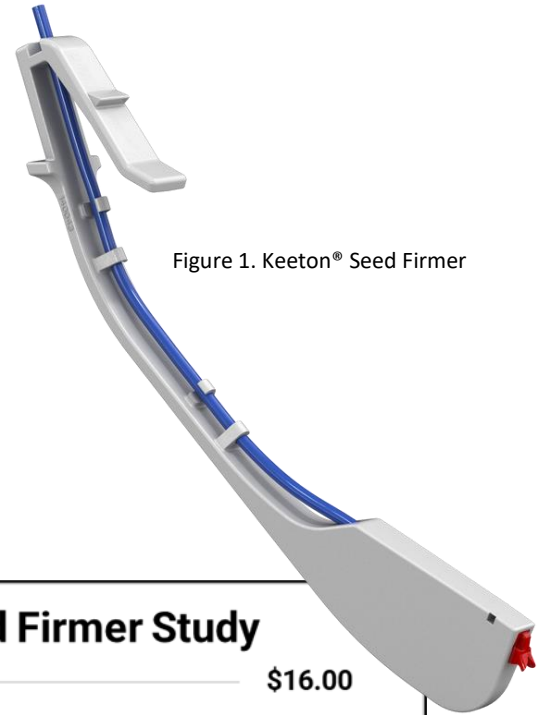
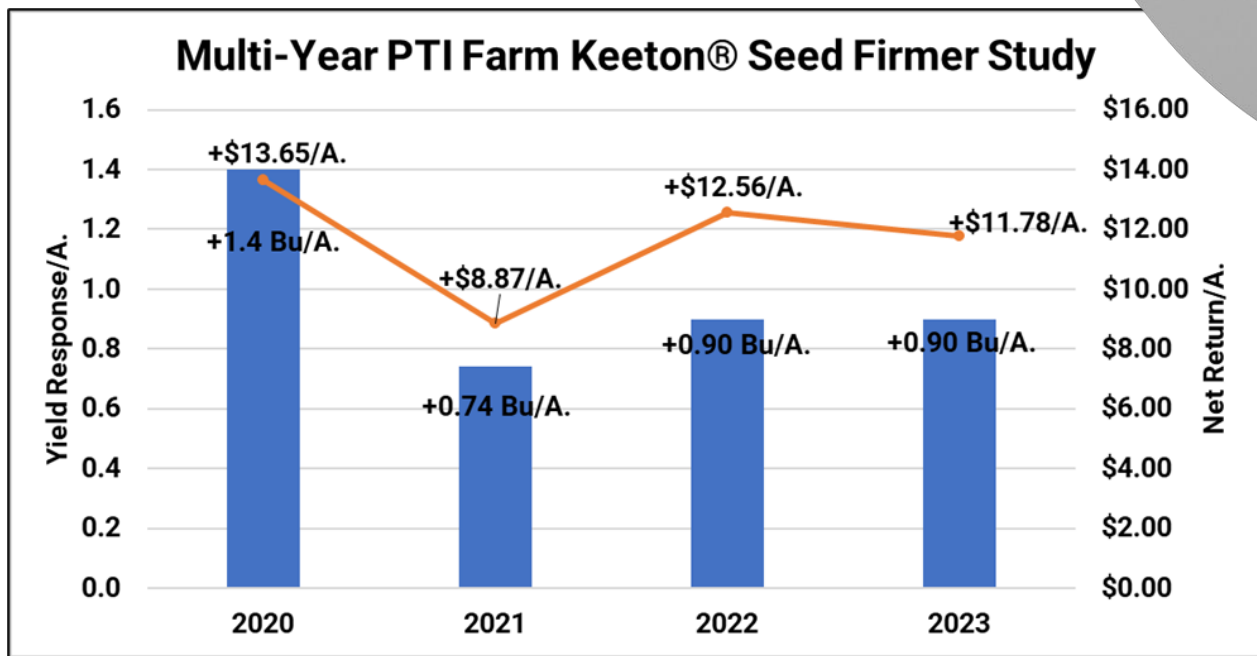


Figure 1. Keeton® Seed Firmer



Planting Date: May 5th Variety: Asgrow 33XF3 Population: 130K Row Width: 30" Rotation: BAC Soybean Price: \$13.09

Soybean Singulation Study

Objective: To evaluate the agronomic and economic advantage of singulating soybeans. In this study we compare the use of an 80-hole vs 56-hole soybean crop kit (Figure 1). Typical spacing of soybean plants achieved with singulation is illustrated in Figure 2.

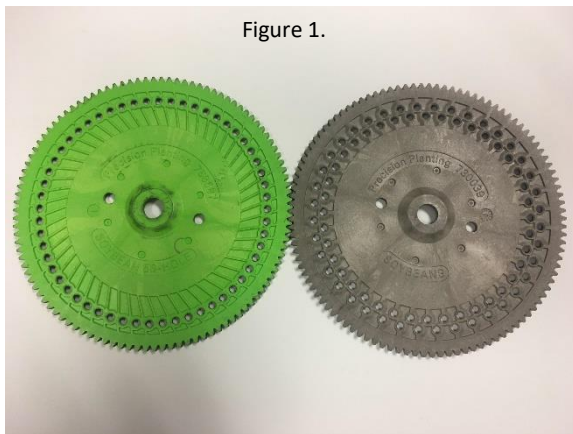


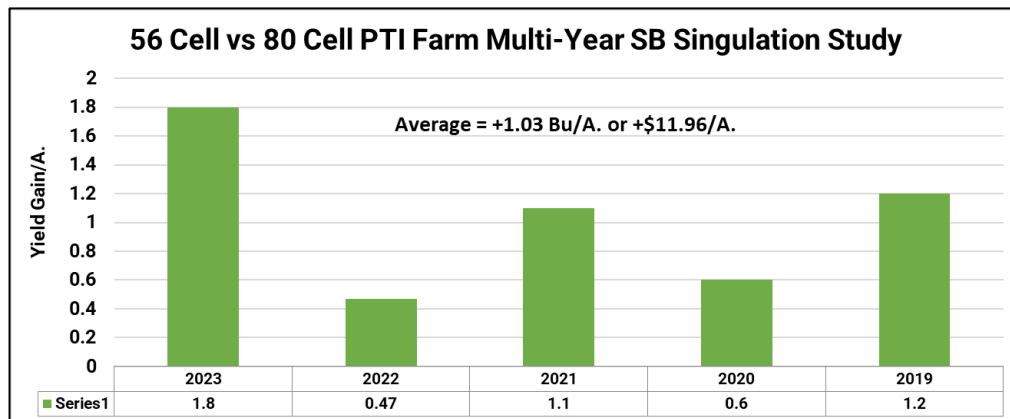
Figure 1.



Figure 2.

Results: The table below summarizes the yield increase of singulating soybeans with a 56 hole crop kit. 2019-2023 proved a +1.03 Bu/A. yield gain over this time period. Using these yield gains, along with the commodity price for each year, shows a +\$11.96/A. advantage over the gray 80 hole-disc.

The cost of upgrading to the 56-hole disc and new ejector wheel is \$16 a row assuming you already have a singulator. When using multi-year economic data, on a 16-row planter it would take a grower 22 acres to break-even on this low cost investment.



Planting Date: May 17th Variety: Pioneer® 37A18E Population: 125K Row Width: 30" Rotation: BAC Soybean Price: \$13.09

SeedRight BundleDrop Singulation Study

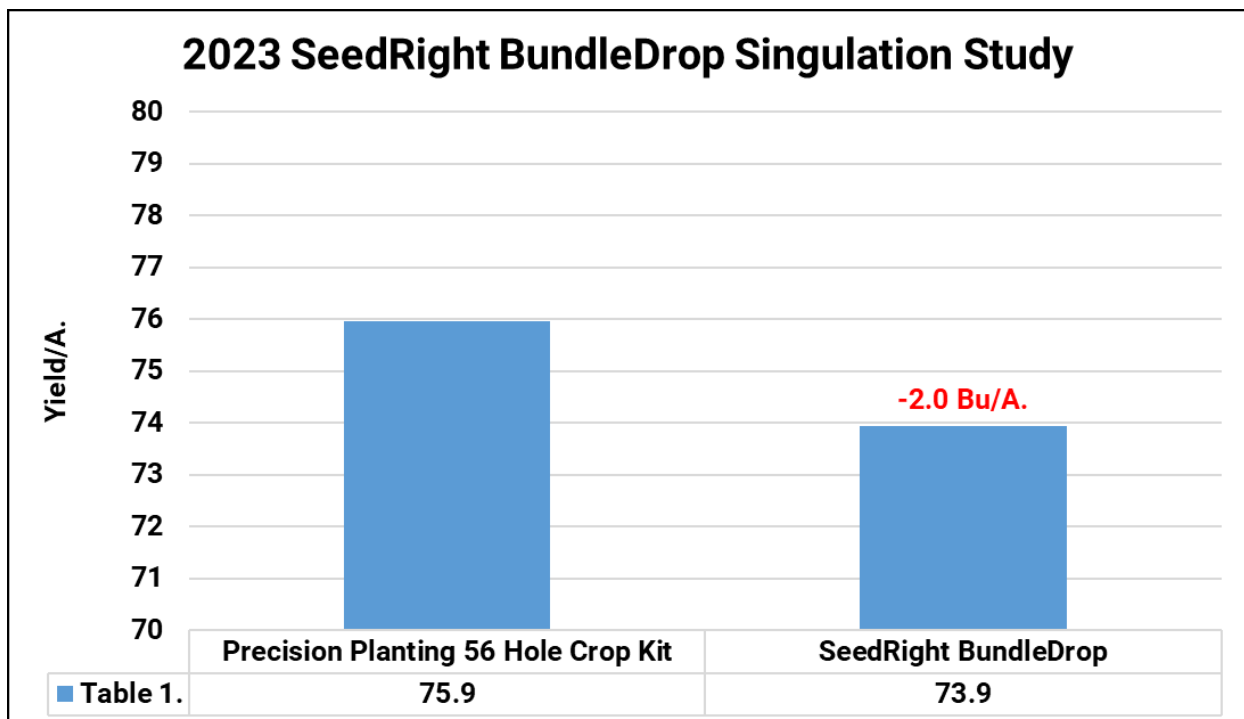
Objective: To evaluate the agronomic and economic advantage of planting soybeans into “bundles”. The SeedRight BundleDrop plate allows the ability to plant soybeans in bundles of four seeds. This “team” approach is designed to help improve emergence and overall plant stand by multiple soybean plants emerging at the same time in a concentrated area to fight through soil crusting.

Results: Table 1. illustrates a yield detriment of **-2.0 Bu/A.** for bundling seeds of four together with the SeedRight disc.

In our second year of testing BundleDrop, multi-year data proves **-2.4 Bu/A.** with corresponding economic losses of **-32.42/A.**



Figure 1. BundleDrop Plate



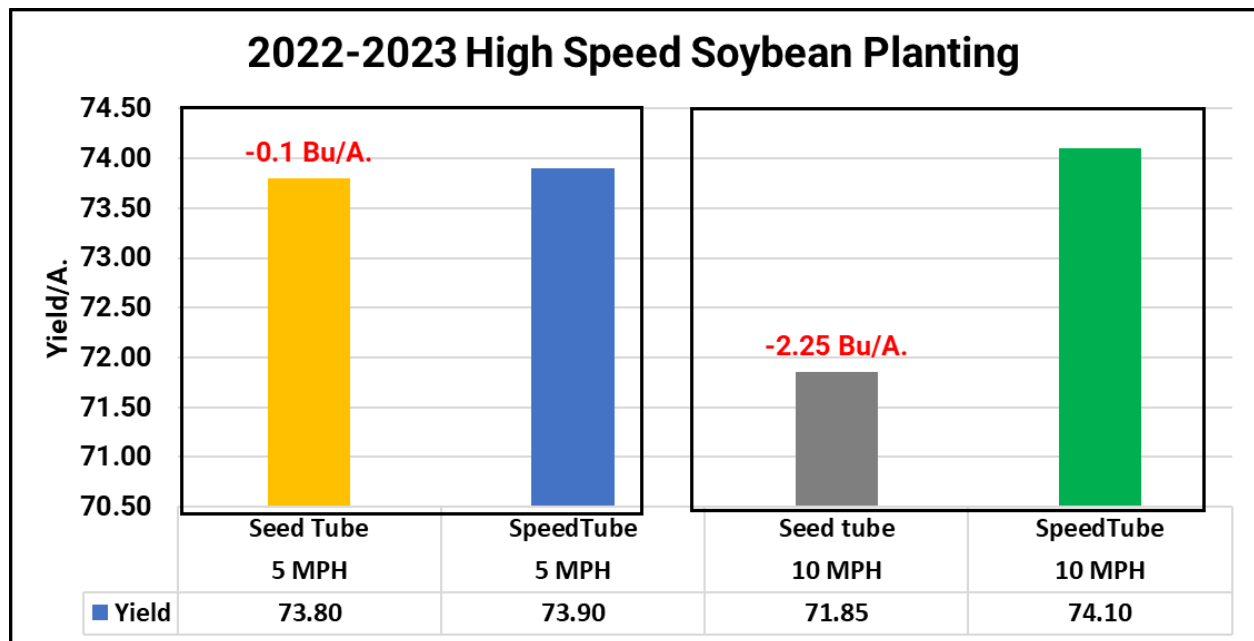
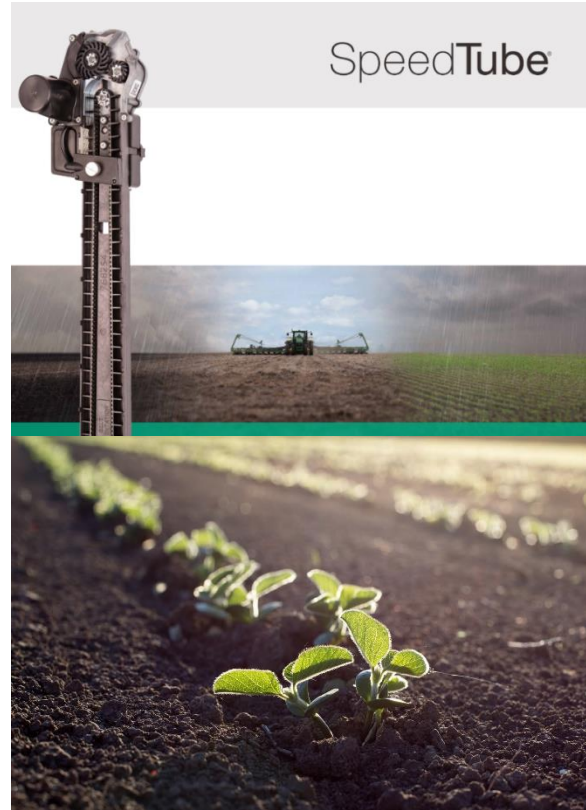
Planting Date: May 17th Variety: Asgrow 27FX3 Population: 130K Row Width: 30" Rotation: BAC Soybean Price: \$13.09

High Speed Soybean

Objective: To evaluate yield response of planting speeds 5 and 10 MPH with a SpeedTube® and regular seed tube system. SpeedTube® high-speed planting technology takes the place of conventional seed tubes and consists of a flighted belt. By transporting each seed to the furrow, there is no opportunity for seeds to ricochet into the trench. Even at twice normal planting speeds, seed arrives safely at the bottom of the trench, spaced evenly, every time.

Results: Using SpeedTube® technology, there was only a 0.1 Bu/A. range difference at planting speeds of 5MPH between the two systems. However, at 10MPH SpeedTube proved additional yield gains of +2.25 Bu/A. compared to a normal seedtube system.

This data would suggest that growers can plant at significantly higher speeds with SpeedTube® technology without sacrificing planter performance.



Soybean Closing Wheel Study

This closing wheel study evaluates yield and economics of six distinctly different types of closing wheel systems including the following:



FurrowForce® Closing and Automatic Control System:

- Advantages:
- Lifts and fractures sidewall compaction/smear
 - 2nd stage stitching and removal of air pocket
 - Ability for automatic sensing/control of soil variability
- Disadvantages:
- Rocks can be problematic, increased cost



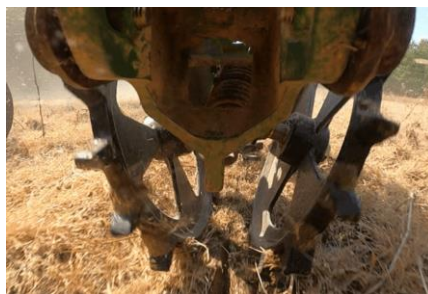
Non-Sensing Traditional Dual Rubber Closing System:

- Advantages:
- Sealing or "Pinching" in dry conditions
- Disadvantages:
- Difficult to lift/fracture sidewalls, struggles to close furrow



Non-Sensing Dual Yetter Poly Twister® Closing System:

- Advantages:
- Lifts and fractures sidewall compaction/smear
 - Center ring acts as depth maintainer
- Disadvantages:
- Lightweight wheels require increased tension



Non-Sensing Martin-Till® fCrusher Closing System:

- Advantages:
- Tapered tooth design – Lightweight Cast
 - Allows firming and crumbling.
- Disadvantages:
- Single Stage, Potential to Overpack



Non-Sensing Dual Germinator® System:

- Advantages:
- Ring-only option for easy installation
 - Center ring acts as depth maintainer
- Disadvantages:
- Single Stage, Potential to Overpack

Soybean Closing Wheel Study Continued



Non-Sensing Martin-Till® Two Stage System:

- Advantages:**
- Lifts and fractures sidewall compaction/smear
 - 2nd stage removal of air pocket
 - Multiple Manual Settings for easy adjustment
- Disadvantages:**
- Manual control – no sensing

Results: Table 1 Illustrates FurrowForce® Auto Standard proved positive yield gains over all other closing systems.

FurrowForce® Manual 35# was **-0.7Bu/A.** off Auto Standard. Martin 2-Stage system came in next, with **-1.3Bu/A.** off FurrowForce®. The other 3 single stage system had the most agronomic loss of **-2.1Bu/A** to **-3.0Bu/A.** respectively.

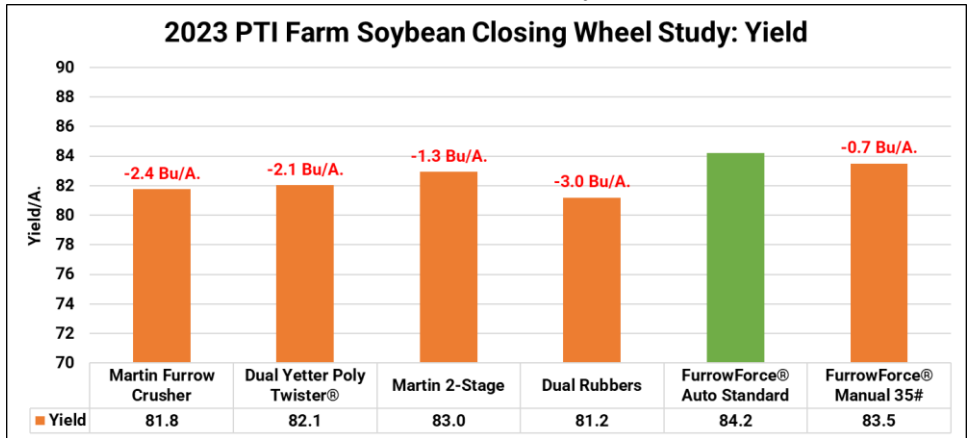
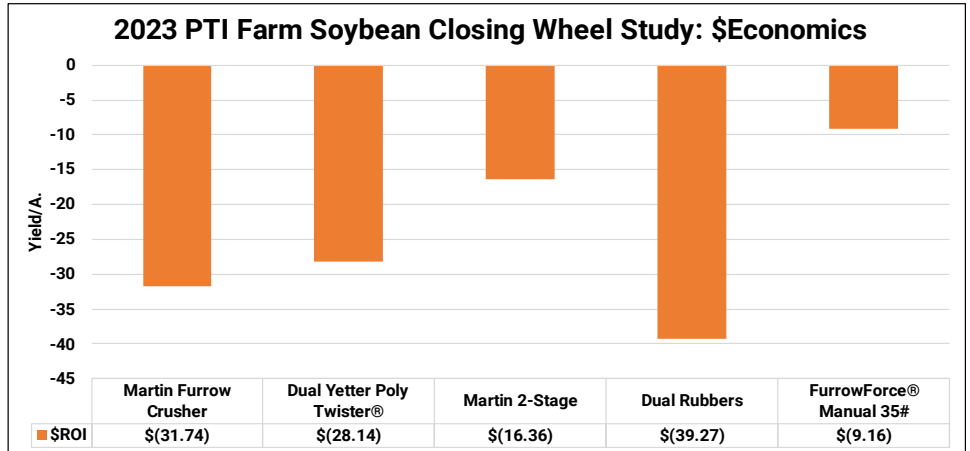


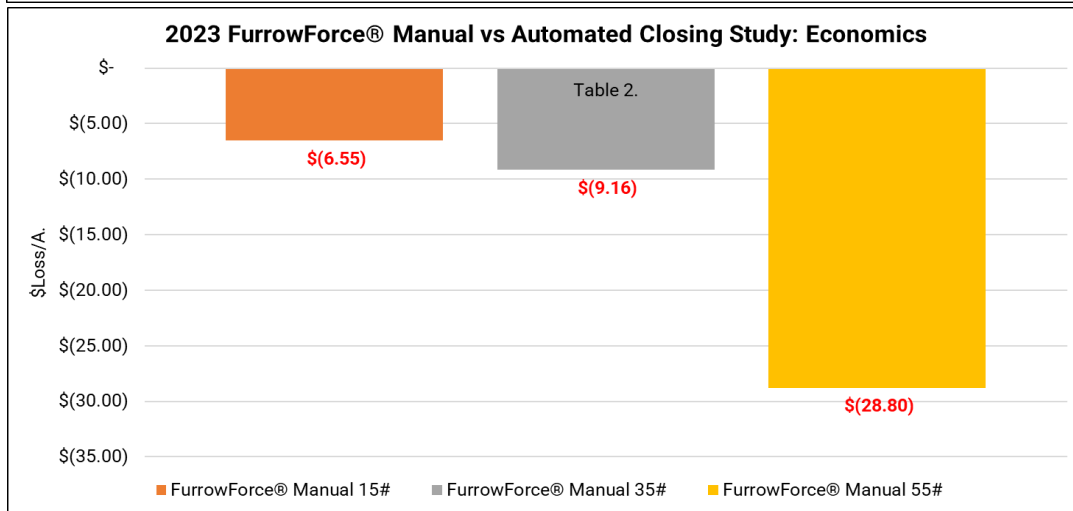
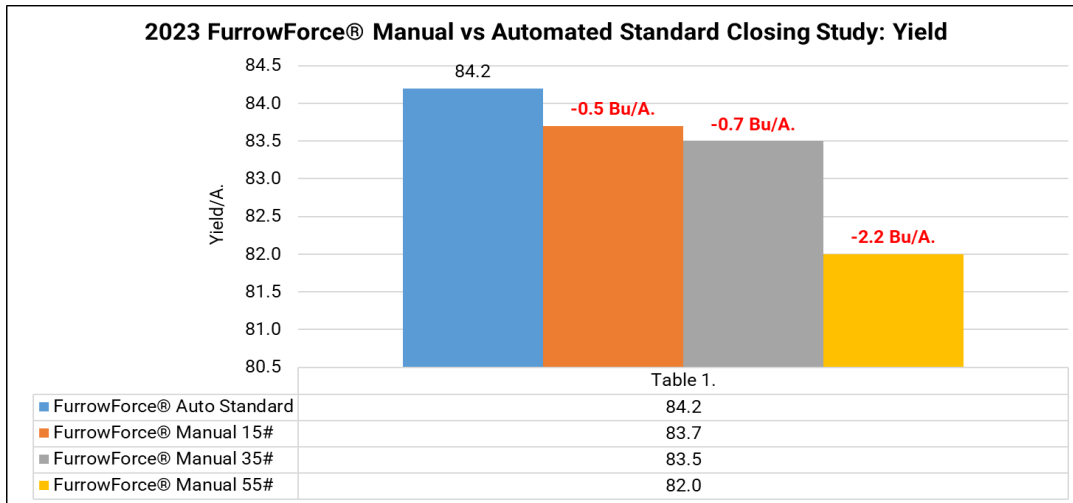
Table 2 Illustrates economics for each of these individual closing systems. FurrowForce® Manual 35# realized economic losses of **-\$9.16/A.** compared to Auto Standard FurrowForce®. Martin 2-Stage manual closing system was **-\$16.36/A.**

off the pace. All other single stage manual closing systems incurred net losses of **-\$28.14** to **-\$39.27/A.** respectively.



Soybean Closing Wheel Study Continued

Tables 1 and 2 illustrate FurrowForce® Auto Standard, compared to Manual FurrowForce® at 15#,35#, and 55#. As we get more aggressive manual with FurrowForce® our yield starts to drop, as well as net losses start to increase.



In summary, for years planters have struggled with closing systems with manual settings that offered the inability to account for and change for varying soil conditions. Today, we are excited that technology finally exists where farmers can use sensing technology on the planter row unit to determine how much force is needed on closing systems to address soil variability. By using a robust 2-stage closing system, load pin and sensing architecture, partnered with a 20|20® monitor, farmers can be confident of closing the seed trench, eliminating sidewall compaction/smearing, and removing air pockets all while planting through various seedbed conditions on a pass-pass basis.

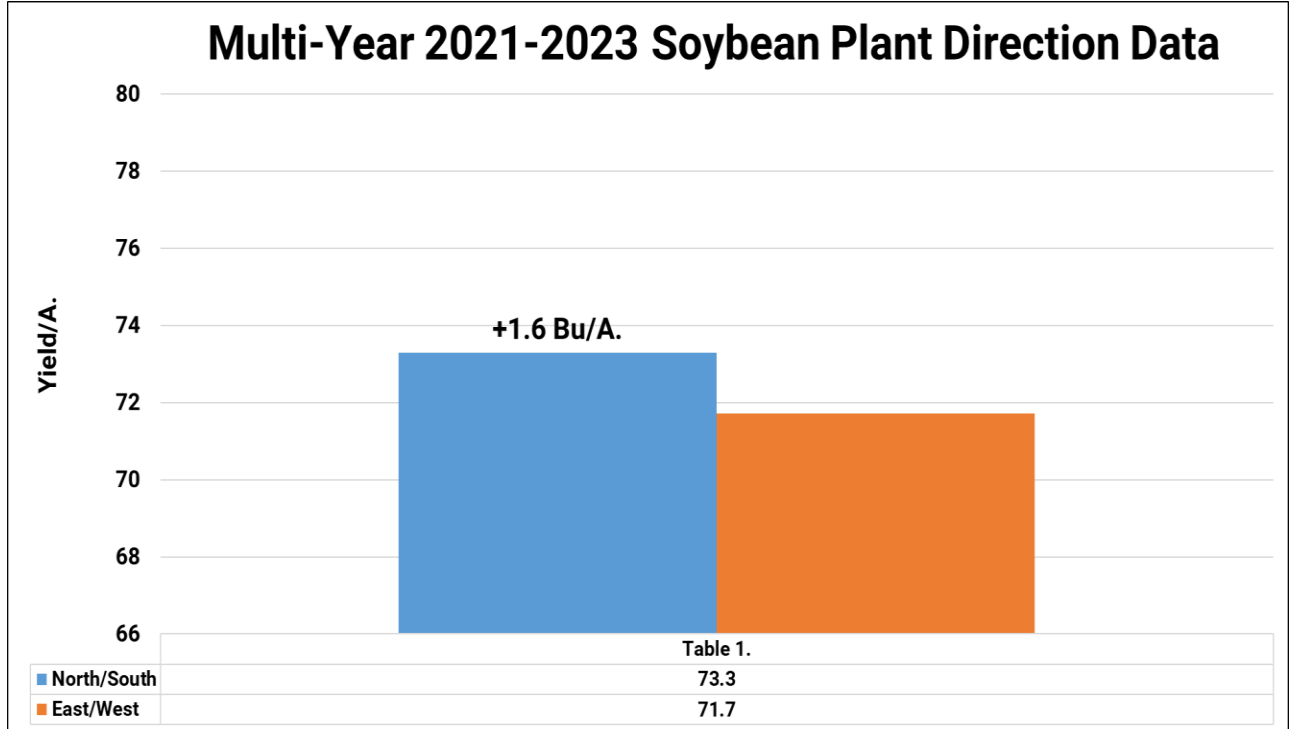
Soybean Directional Planting Study

Objective: To study yield impact from planting soybeans in a North/South vs East/West fashion. In other words, does it make a difference which direction a grower plants soybeans?

Most farmers plant their fields based on the way the field is laid out, the way water flows, tract size, or other factors on their individual farms but we wanted to establish if there was a difference in yield from these two directions in 30" rows.



Results: Table 1. illustrates multi-year results of data at the PTI Farm from 2021 to 2023. Based on these three years, soybeans planted in a North/South fashion have proved a +1.6 Bu/A. advantage versus East/West planting direction.



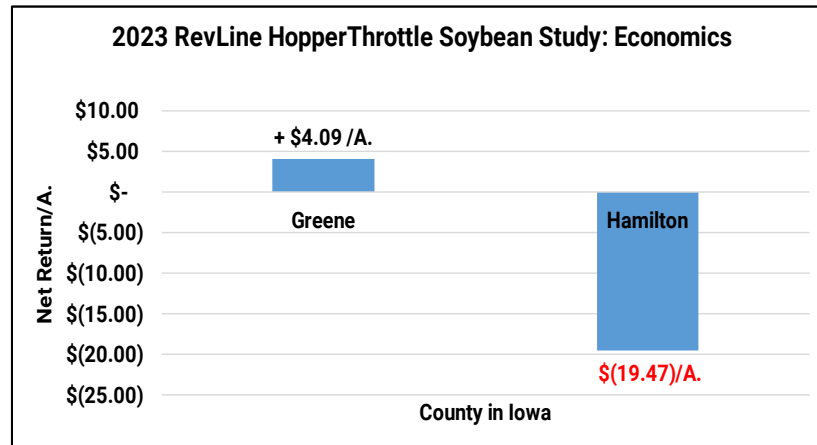
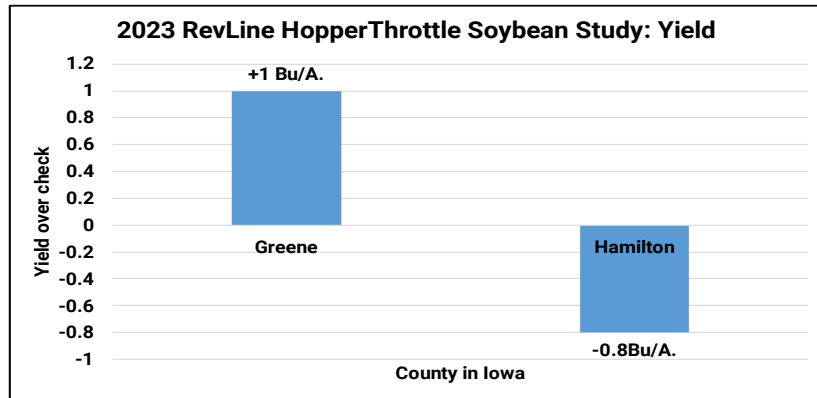
REVLIN® HOPPER THROTTLE™ Hopper Box Treatment PTI Partner Trial

Objective: To evaluate yield and net return of REVLIN® HOPPER THROTTLE™. This trial was done as a PTI partner trial, implemented by Arnold Farms in Hamilton and Greene County, Iowa.

HOPPER THROTTLE™ is a 80/20 talc graphic blend for planters that also contains Manganese, and Zinc. It places essential nutrition, flow agents, and crop enhancement components directly on the seed to aid in singulation and improve seedling vigor and growth.



Results: HOPPER THROTTLE™ hopper box treatments offered average yield gains of +0.1 Bu/A. with a average negative net return on investment of **-\$7.69/A.**



Planting Date: March 19 Hybrid: Integra 6641SS Population: 26K Row Width: 30" Rotation: CAB Corn Price: \$5.31 HOPPER THROTTLE: \$9.00 Talc/Graphite: \$0.15/A.

Soybean Cover Crop Study:

Objective: This trial is designed to evaluate the yield and economic benefits of a cover crop system in a soybean/corn rotation. To evaluate long-term benefits, this trial has been designed as a 10-year study. 2023 is year 3 of the 10-yr trial.

45#/A. of a cereal ryegrass/barley mix was planted in the fall of 2022 (Figure 1.) and strip-till was then used as the primary tillage system after the ryegrass emerged. In the spring, soybeans were planted directly on the fall strips and into the green cover crop (Figure 2). Termination of the cover crop was implemented at when rye achieved 24" in height.

Figure 1. Fall Cover Crop Seeding



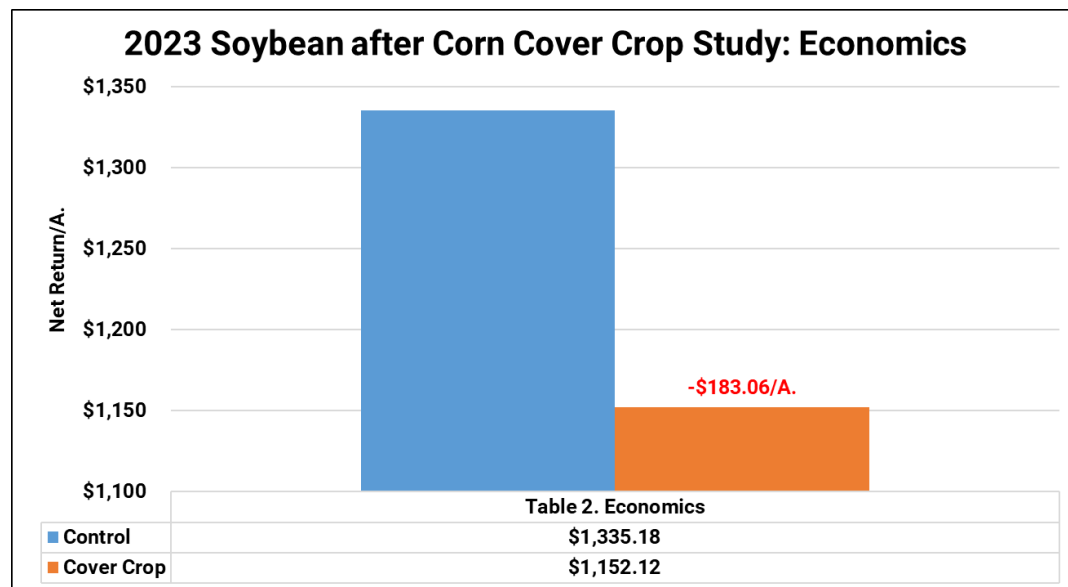
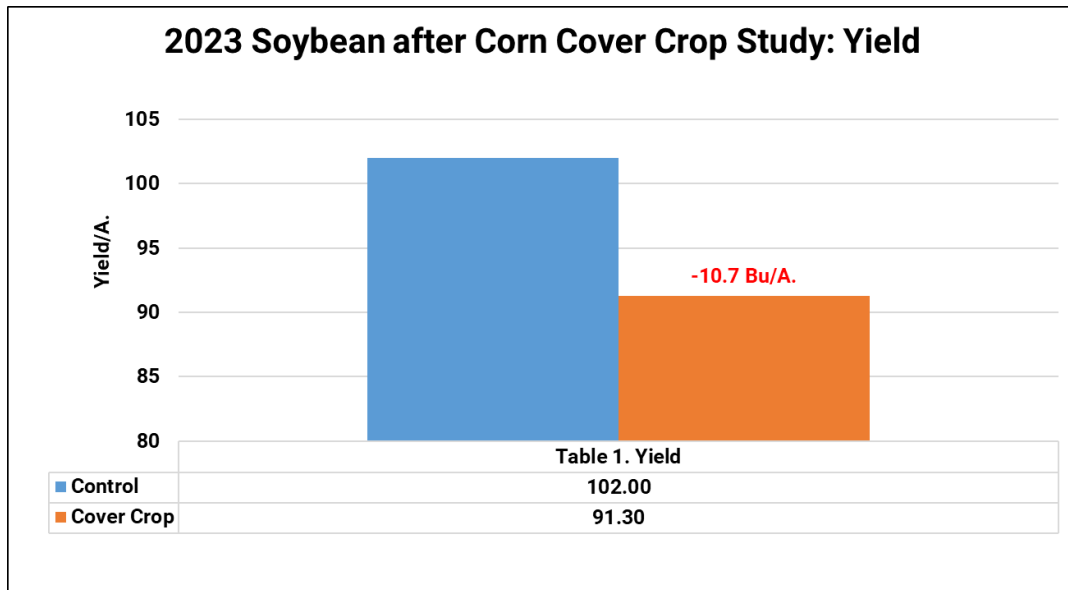
Figure 2. Planting on Strip-Till into Green Cover



Soybean Cover Crop Study Continued

Results: Excellent yields were obtained in both this non-irrigated cover crop study with yields averaging 91.3 to 102 Bu/A. However, Table 1. illustrates soybeans in the cover crop system proved **-10.7 Bu/A.** yield losses to the non-cover crop control.

Table 2. depicts net return on investment of the cover crop system. After the yield losses and the cost of seed and planting, the cover crop system offered huge economic losses in 2023 of **-\$183.06/A.**



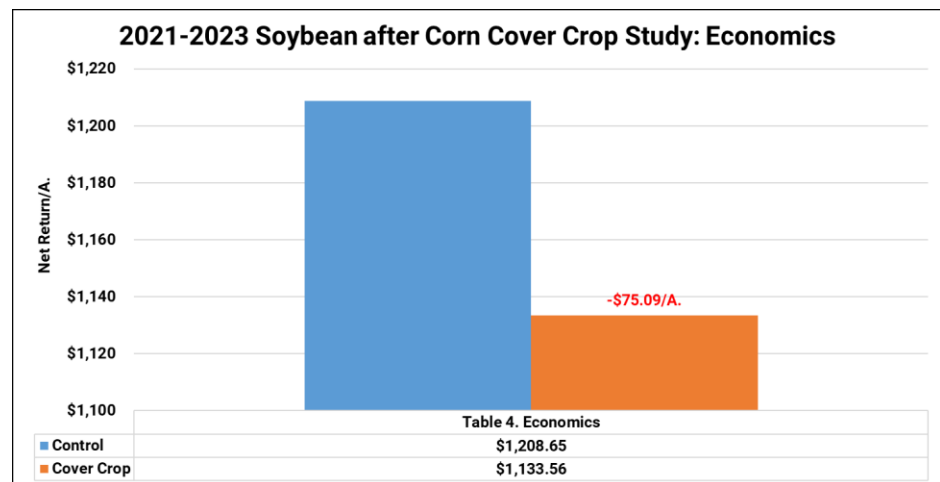
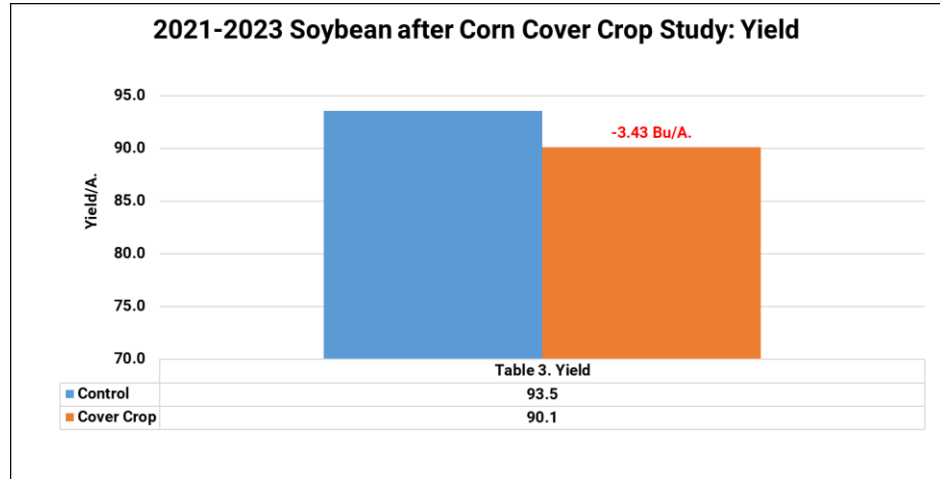
Soybean Cover Crop Study Continued

At the PTI Farm, we believe we need to evaluate the performance of cover crops over time. As a 10-yr study this will allow us to measure annual average cash flow, along with hopefully the increase of soil health over time. Table 3. illustrates multi-year yield data and after three years of evaluating soybeans planted into a cover, yield losses today stands at **-3.43 Bu/A.**

More importantly, Table 4. explains the multi-year economics. Soybeans in a cover crop system at the PTI Farm have resulted in economic losses **-\$75.09/A.** thus far in three of our ten-year program.

It should be important to note that no program or subsidy cost reimbursements are calculated in this study. If a grower were to qualify for a program, it could help discount the cost of the cover program and help offset losses.

We look forward to continuing to test the use of cover crops in a soybean after corn rotation and to evaluate yield and economics of the system, while taking a close look at what cover crops can offer regarding soil health improvement. While the PTI Farm has lower soil erosions concerns due to smaller degrees of slope, we are trying to understand other advantages that a cover crop system could add to favor farm sustainability.



Broadcast vs Banding Dry Fertilizer Study

Objective: To evaluate yield and economics of traditional broadcast applications of dry fertilizer compared to 8" deep high concentrated strip-till banding.

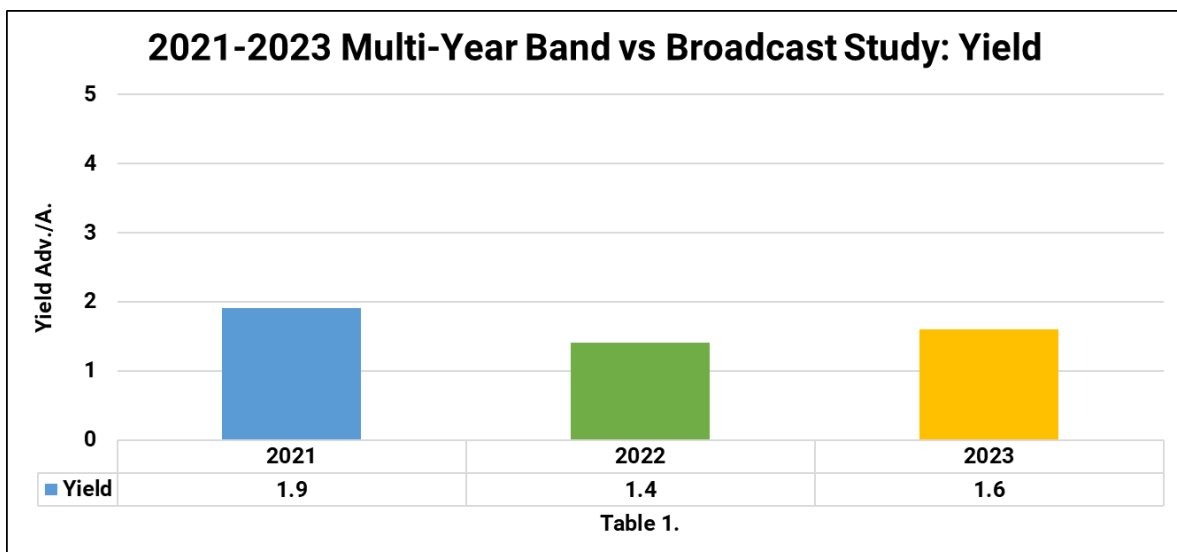
Based upon soil test results and yield goals of 70 Bu/A. soybeans in a corn/soybean non-irrigated rotation, 18-46-0 and 0-0-60 was applied in a traditional broadcast surface application made with a traditional spinner truck (Figure 1). Using the same fertilizer rates, a strip-till bar was used to place fertilizer in high concentrated strips 8" deep on 30" corn rows (Figure 2). A KUHN® Krause® Gladiator® pulling a Montag® Equipment 2208 Gen 2 fertilizer cart was used to implement this testing program for 2023.

Results Table 1. illustrates strip-till fertilizer has resulted in average yield gains of +1.6 Bu/A. over traditional broadcast applications.

Figure 1. Broadcast Dry Fertilizer



Figure 2. Strip-Till Banded Fertilizer

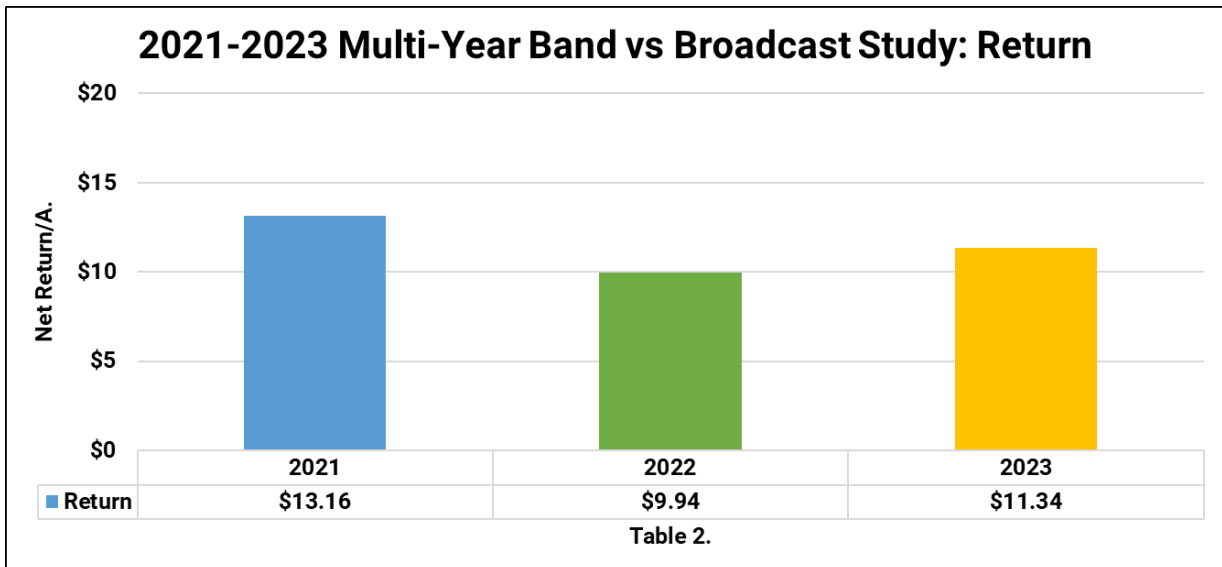


Broadcast vs Banding Dry Fertilizer Study Continued

Using University of Illinois Machinery Cost Estimates in Figure 3., strip-till resulted in additional costs of +\$9.60/A. in comparison to a conventional tillage program. Using this cost scenario, Table 2. illustrates the economic impact from our 2023 study. Strip-till, with its tillage and fertility system, posted positive economic gains of +\$11.34/A. over a conventional tillage system. 2021 and 2022 saw similar net returns of +\$13.16 and +\$9.94/A.

Figure 3. University of IL Machinery Cost Estimates

Tillage Practice	Category	Cost
Conventional	Soil Finisher	\$ 11.10
	Plant	\$ 17.20
	Fertilizer Spread	\$ 3.00
	Total:	\$ 31.30
Strip Till	Strip	\$ 17.30
	Plant	\$ 17.20
	Burndown	\$ 6.40
	Total:	\$ 40.90



Broadcast vs Banding Rate Efficiency Study

Objective: To evaluate yield and economics of traditional broadcast applications of dry fertilizer compared to concentrated strip-till bands applied 8" in depth under the corn row.

To study placement efficiency, dry fertilizer was applied in a traditional broadcast surface application as a spinner truck (Figure 1.) and soybeans were planted into strip-till tillage program.

Using the same fertilizer rates, a strip-till bar was then used to place fertilizer in high concentrated strips 8" deep on 30" corn rows (Figure 2). Soybeans were then planted directly into those strips above the 8" fertilizer placement.

A KUHN® Krause® Gladiator® pulling a Montag® Equipment 2208 Gen 2 fertilizer cart was used to implement this testing program for 2023.

To then study rate efficiency, fertilizer was applied at the following rate structure in both strip-till bands and broadcast applications:

- ✓ 100% Fertilizer Rate
- ✓ 75% Fertilizer Rate
- ✓ 50% Fertilizer Rate
- ✓ 25% Fertilizer Rate
- ✓ 0# Rate

Figure 1. Broadcast Dry Fertilizer



Figure 2. Strip-Till Banded Fertilizer with Montag® cart



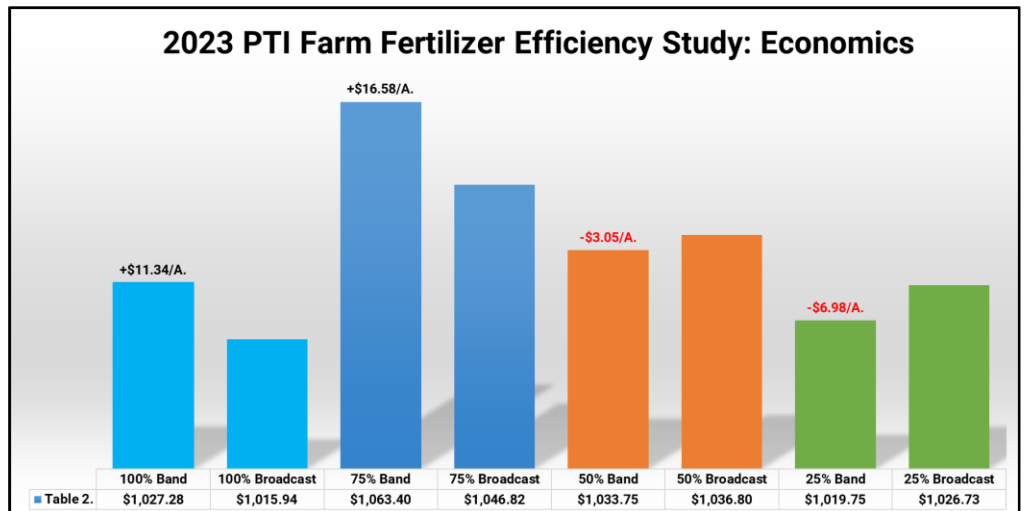
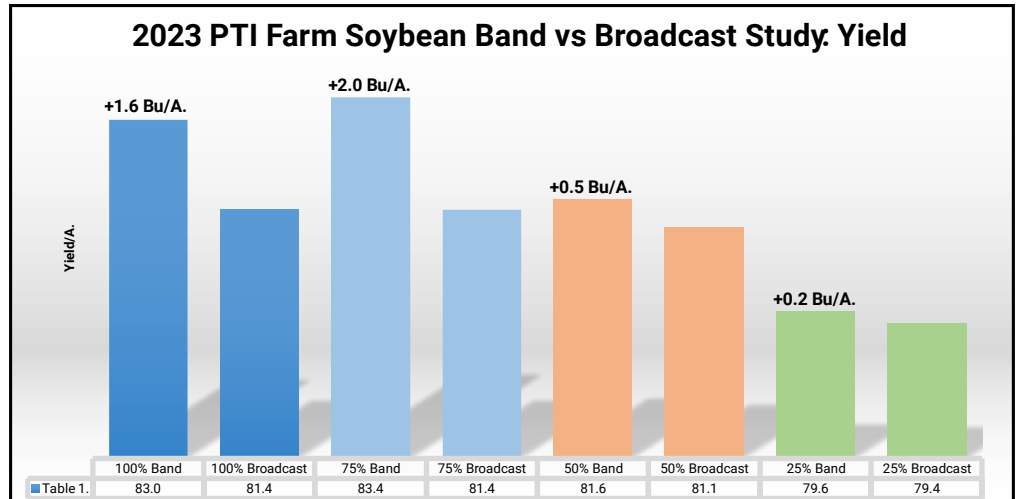
Figure 3. KUHN® Krause® strip-till unit



Broadcast vs Banding Rate Efficiency Study Continued

Results: Table 1. summarizes banding advantage over broadcast applications at all individual rates. Banding outperformed all broadcast applications at every rate, with 100% and 75% offering the highest advantages at +1.6 to +2.0 Bu/A. As rates fell to 50% and 25%, banding advantages were reduced to only +0.2 to +0.5 Bu/A.

Table 2. illustrates that banding fertilizer offered additional returns of +\$11.34 to +\$16.58/A., with 75% fertilizer rate offering highest efficiency.

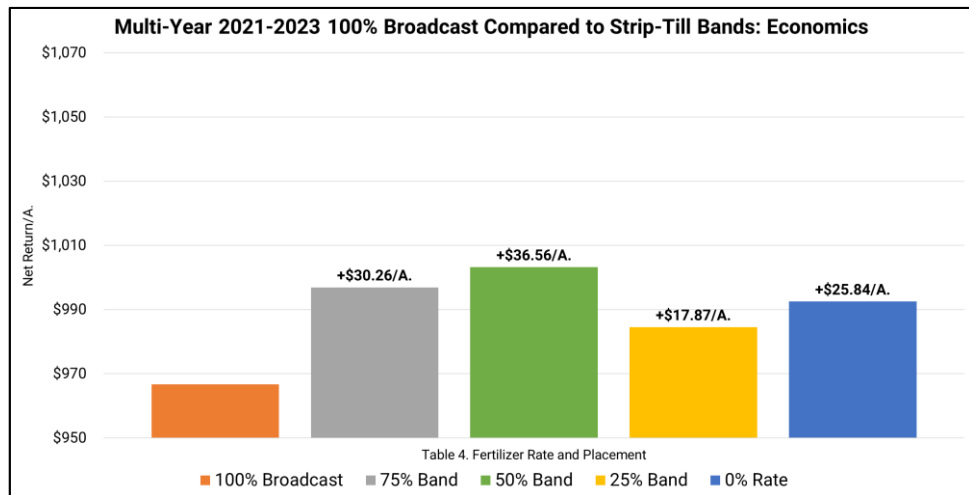
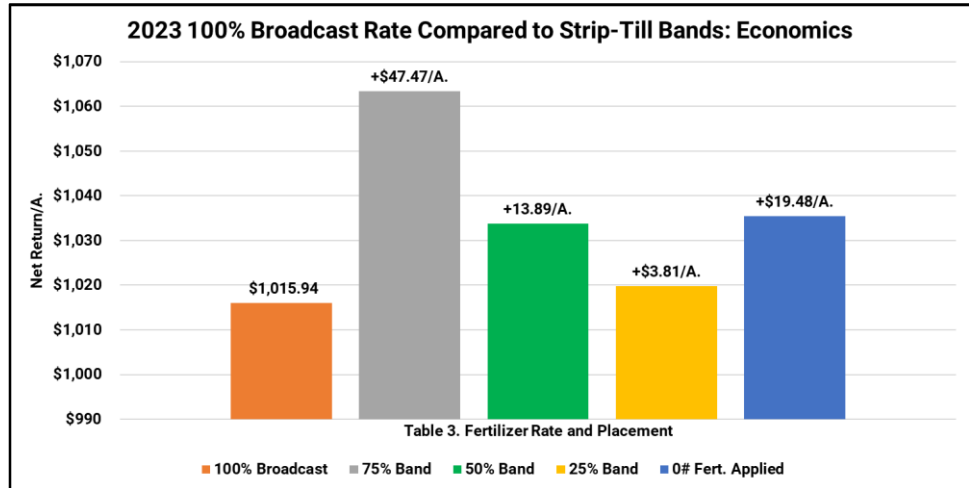


Lowering fertilizer to 50% rate in bands proved losses of **-\$3.05/A.**, while 25% reduced banded rates at **-\$6.98/A.** Each of these losses were a result of little yield difference, but higher equipment cost for application.

Broadcast vs Banding Rate Efficiency Study Continued

Table 3. helps answer the question surrounding banding efficiency. In other words, if I place fertilizer in bands, can I reduce the rate due to its efficiency? In 2023, banding 75% of recommended fertilizer rate, netted an additional +\$47.47/A. compared to traditional broadcast spreading. As fertilizer rate was reduced to 50%, it offered +\$13.89/A. over 100% broadcast rates and 25% near break-even at +\$3.81/A. However, what's disturbing is that applying 0% rate fertilizer offered advantages over the 100% broadcast rate by +\$19.48/A. This simply means that there was not enough yield advantage from fertilizer to offset the high price of dry fertilizer.

Table 4. summarizes multi-year data over 2021-2023. Banding 75%-50% rates of fertilizer have led to returns of +\$30.26 to +\$36.56/A. over traditional broadcast spreading. However, just as 2023 revealed, 0% rates were very close at +\$25.84/A.



As part of a 10-year study, this will be interesting to evaluate over the next 7-year period to analyze yield and economics as fertilizer prices hopefully fall back to somewhat normal levels.

Planting Date: April 20th

Variety: Asgrow® 27FX3

Population: 120K

Row Width: 30"

Rotation: BAC

SB Price: \$13.09

Strip-till: +\$9.60 18-46-0:\$870/T 0-0-60:\$770/T

Avg Soil Test Level: P:68#/A. K: 393#/A.

Liquid vs Dry Fertilizer Fall Strip-Till Study

Objective: To evaluate yield and economic impact of dry and liquid fertilizer program in fall strip-till bands. This 1st year study compares a traditional dry 18-46-0 and 0-0-60 fertilizer program versus a replacement liquid fertilizer program. Treatments were as follows:

#1: 100% Dry Fertilizer Program:

150# 18-46-0 + 150# 0-0-60

#2: 50% Dry Fertilizer Program:

75# 18-46-0 + 75# 0-0-60

#3: Control: No Fertilizer Applied

#4: Liquid Fertilizer Program: 50% Nutrient Equivalent to Dry Program

12.5 Gal/A. Nachurs® Throwback® 9-27-4-4S

20 Gal/A. Nachurs® K-flex® 0-0-19-6S



#5: Liquid Fertilizer Program: 100% Nutrient Equivalent to Dry Program

25 Gal/A. Nachurs® Throwback® 9-27-4-4S

40 Gal/A. Nachurs® K-flex® 0-0-19-6S



Liquid vs Dry Fertilizer Fall Strip-Till Study

All liquid treatments were applied in the Fall made with Black Eagle Ag Solution's strip-till unit.



This bar was fitted with Pump Stack® (Figure 1.), a liquid fertilizer hydraulic pump. It was paired with EMHD®, and EM Flowsense™ (Figure 2.) to ensure a top-notch fertilizer application, as well as row control across the bar. EMHD® controls liquid application rates using an electromagnetic flow meter. This opens your options for a wider range of liquid products. EM Flowsense™ allows you to measure the rate of fertilizer you are applying on each row of the bar, to make you aware of any row-to-row variability that is occurring. With a Pump Stack® system, paired with EMHD®, and EM Flowsense™ you can be confident in your application rate across every row.



Figure 1. Pump Stack®

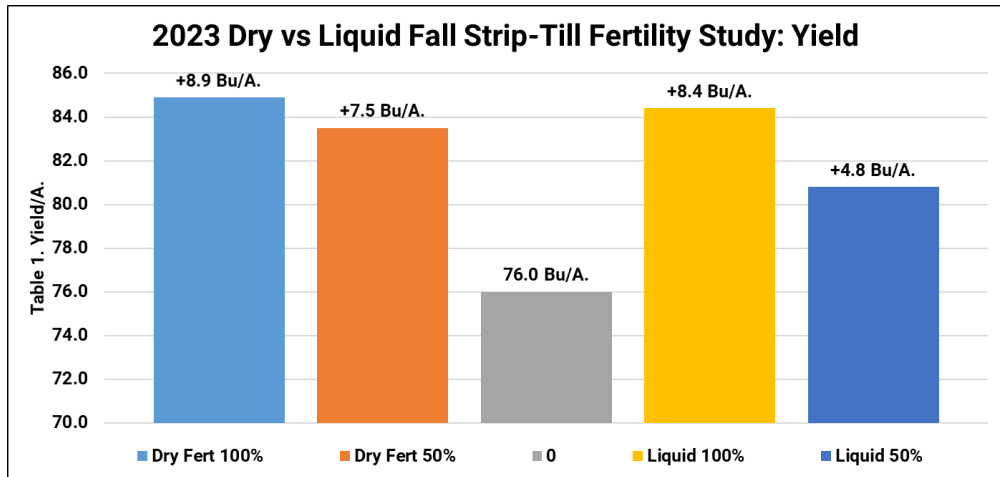


Figure 2. EMHD® + EM Flowsense™

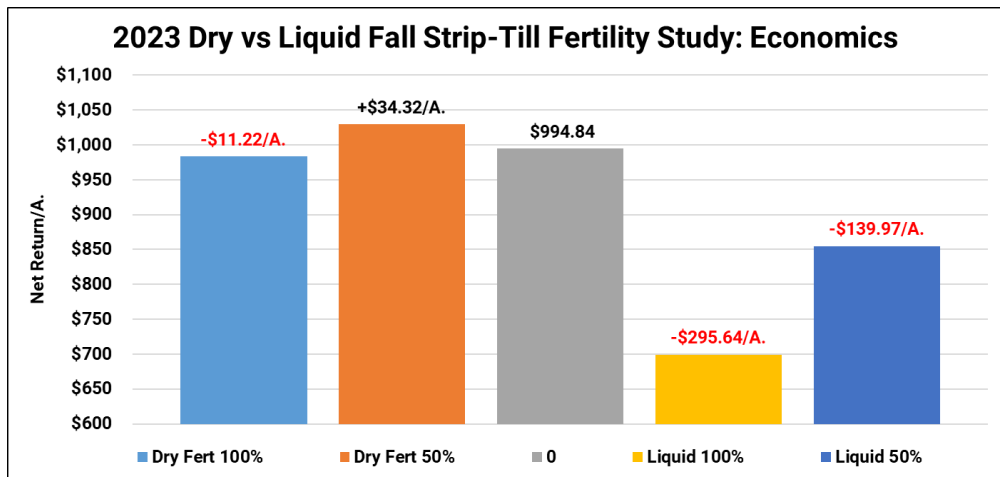
Liquid vs Dry Fertilizer Fall Strip-Till Study

Results: Table 1. illustrates 0# control treatments resulted in soybean yield of 76.0 Bu/A. Both 100% rate dry and liquid rates offered nearly similar performance, with yield increases of +8.9 and +8.4 respectively. 50% dry rates proved +7.5 Bu/A. yield gains; however 50% liquid rates fell to gains of only +4.8 Bu./A.

Table 2. reveals the overall economics of the fertilizer study and proved significant losses at both 50% and 100% rates of liquid fertilizer at **-\$139.97** to **-\$295.64/A.**



100% dry rates of fertilizer also proved losses of **-\$11.22/A.**, while the only entry to garner positive return on investment was the 50% rate at **+\$34.32/A.**



Overall, the Black Eagle strip-till

unit performed well regarding tillage. However, due to the high cost of fertilizer the liquid applications failed to achieve profitability of the dry program.

Calcium Products™ 98G® Pell Lime Soybean Study:

Objective: This trial evaluates the yield response and economics of pelletized limestone (98G®) applied fall broadcast. Soil pH is the foundation of nutrient availability and critical to maximizing crop yield. The availability of all nutrients is impacted by soil pH levels, especially phosphorus (P).

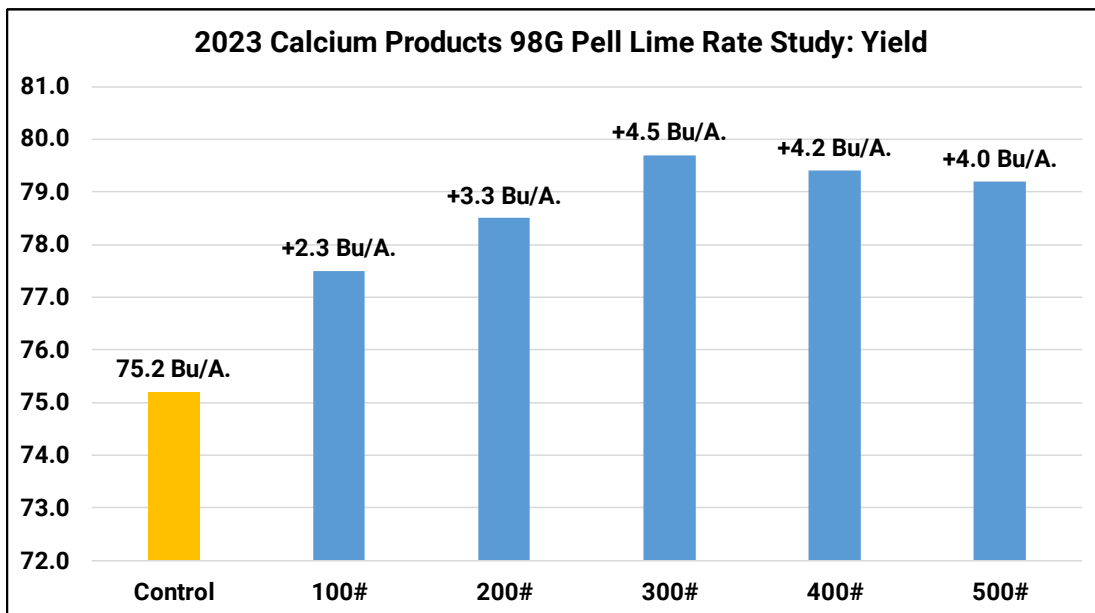


When soil pH is below 6.0, it can reduce your yield by as much as 30%. Calcium Products' 98G® pelletized limestone is the most effective and consistent product to correct and maintain soil pH.

<p>Maintain Soil pH Once soil pH is restored, use 98G to maintain pH levels with more frequent, lower rate applications. Leaving Yield on the table is unacceptable, and maintaining proper soil pH is a critical piece of good fertility management and maximizing yield.</p>	<p>Change Soil pH Quickly 98G corrects soil pH faster and more completely than aglime. It is the most reactive liming material because it's made from 98% pure calcitic limestone and ground to an ultra-fine powder before it is pelletized. 98G pellets are engineered and manufactured to a specific size and hardness so that the pellets handle well and spread uniformly yet break down in the field to change soil pH. 98G is fully reactive at about three to six months after application.</p>	<p>Enjoy Application 98G can be applied in flat-rate or variable-rate applications. It can be mixed with other dry fertilizers reducing the number of trips across the field and spread spring or fall. This flexibility means you can address soil pH when and how it works for you with the same equipment used to spread other dry fertilizers.</p>
---	--	---

Soil pH has traditionally been addressed about every four years with aglime. Rather than create a pH "rollercoaster" in the field with infrequent aglime applications, 98G® can be used as part of a pH maintenance program with annual or biannual applications. 98G® is a more reactive liming material than aglime, keeping soil pH at a level to maximize yield potential (typically 6.0) year after year.

Results: Broadcast treatments of 98G® Pell Lime were applied in rates of 100#-500#/A. in Fall of 2022. All rates proved yield advantages of +2.3Bu/A to +4.5Bu/A. 300#/A. rate proved both economic and agronomic optimum at +4.5Bu/A. and net returns of +\$16.91/A.



Planting Date: May 18th Variety: Asgrow 35FX1 Population: 130K Row Width: 30" Rotation: BAC Soybean Price: \$13.09
Pell Lime: \$240/Ton + \$6/A Application

2023 High Management Soybean: NETAFIM™ Irrigation Study

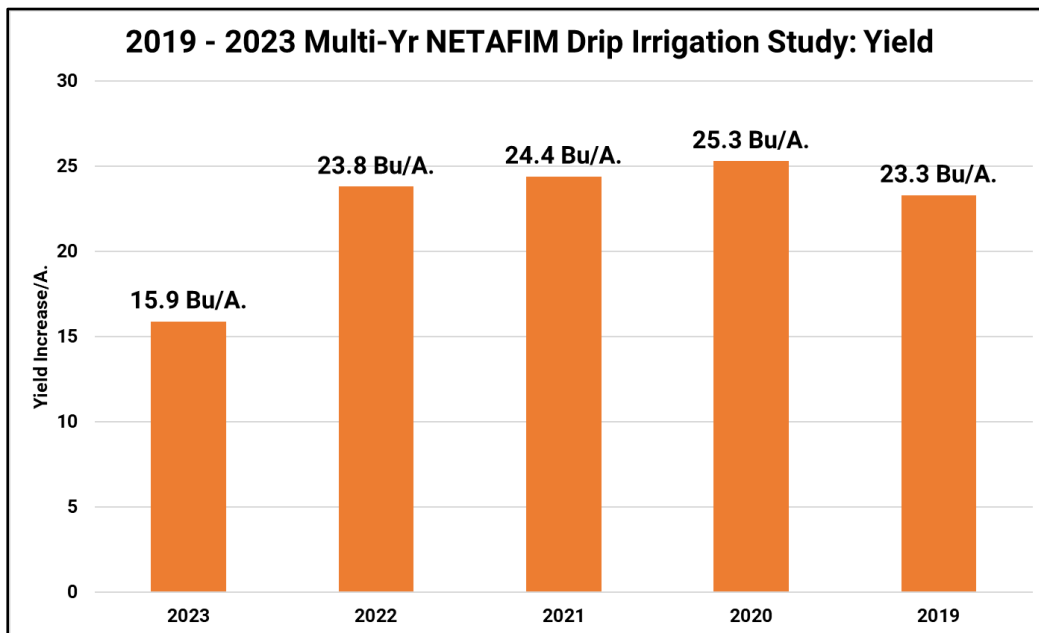
Objective: This study evaluates NETAFIM™ drip tape irrigation designed by NutraDrip Irrigation Systems and its' ability to feed soybeans with water and nutrients for high yield potential. This method of irrigating a crop uses NETAFIM™ drip tape with small pressure regulated emitters evenly spaced at 24" apart. Drip tape in this study is not sub-surface irrigation. It is rather installed on the soil surface to demonstrate how the system works, to growers who come to visit the PTI Farm. Water is accessed from a water recycling management program installed at the PTI Farm.



Results: In 2023, NETAFIM™ drip tape irrigation resulted in average yield increases of +15.9 Bu/A. compared to dryland soybeans. 5" of water was applied through drip irrigation throughout the growing season from June - September. 2023 yield response is the lowest obtained in the 5-yr of drip irrigation at the PTI Farm.



Multi-Year data has proven irrigation to increase soybean yield by an average of 22.5 Bu/A., while increasing additional gross income by an average of +\$256.30/A.



2023 High Management Soybeans: Soybean Seed Size Study

Objective: To evaluate soybean seed size in relation to high yield soybeans.

In our 2023 high management soybean trials, our PTI Team wanted to evaluate the ability to increase soybean seed size, as a result of the various treatments applied throughout the growing season. Seed samples were collected at harvest and then ran through a series of seed counting and weighting exercises to determine actual seed weight and size (Figures 1-2).

Results: Table 1. summarizes the seed size differences of a high managed, irrigated protocol compared to that of a status quo, average management, dry land protocol.

Soybean seed sizes were 16% larger in high management treatments and also exhibited higher test weight by 2.1 #’s/Bu. More work needs to be done to fully understand soybean seed size from various management techniques, but 2023 data suggests bigger beans equates to bigger yields.

2021 data found high management soybeans averaging 2084 seeds/#, 27% larger than low management and 2022 averaged 2750 seeds/#, 14% larger.

Test weight is a “unicorn” to understand, but current overall volumetric grading standards in soybeans usually suggest average soybeans near 57#/Bu in most cases, even though farmers are graded at 60#/Bu.

Figure 1. Large Soybean Seed Size



Figure 2. Soybean Seed Counter



Table 1.

<u>Program:</u>	<u>Seed Size:</u>	<u>Test Weight:</u>	<u>Yield</u>
<u>Status Quo:</u>	<u>2800 Seeds/#</u>	<u>57.0</u>	<u>82.7</u>
<u>High Management:</u>	<u>2340 Seeds/#</u>	<u>59.1</u>	<u>99.3</u>

Nachurs® High Management Soybean Study

Objective: To evaluate the yield and economic impact of a soybean liquid starter fertilizer and foliar nutritional program from Nachurs® in a high management irrigated environment. This trial consisted of the following:

Treatments and Placement:

#1. Control:	Dryland, R2 Miravis®Top, R5 Miravis®Neo
#2 At-Plant Fertility:	
Conceal® Dual Band (Figure 1.)	3 Gal Nachurs Throwback®, 1Qt Nachurs Humi-Flex® Max 1 Gal K-fuse®
FurrowJet® Center: (Figure 2.)	1Pt Rhyzo-Link® PE, 1 Gal Balance® 1Pt Calcium 3%, 1oz NLT 5.1
FurrowJet® Wings: (Figure 2.)	1 Gal Balance®, 2 Gal TripleOption®, 1 Pt FaceOff®
#3 Foliar Applications:	
	V3: 1Qt FinishLine®, 3 Qt TripleOption®
	R1: 1 Gal Nachurs K-flex®, 1 Gal Nachurs imPulse®, 1Qt Nachurs FinishLine®, 4oz Moly
	R3: 1.5 Gal NockOut®, 1Qt SideSwipe®



Figure 1. Conceal® Placement



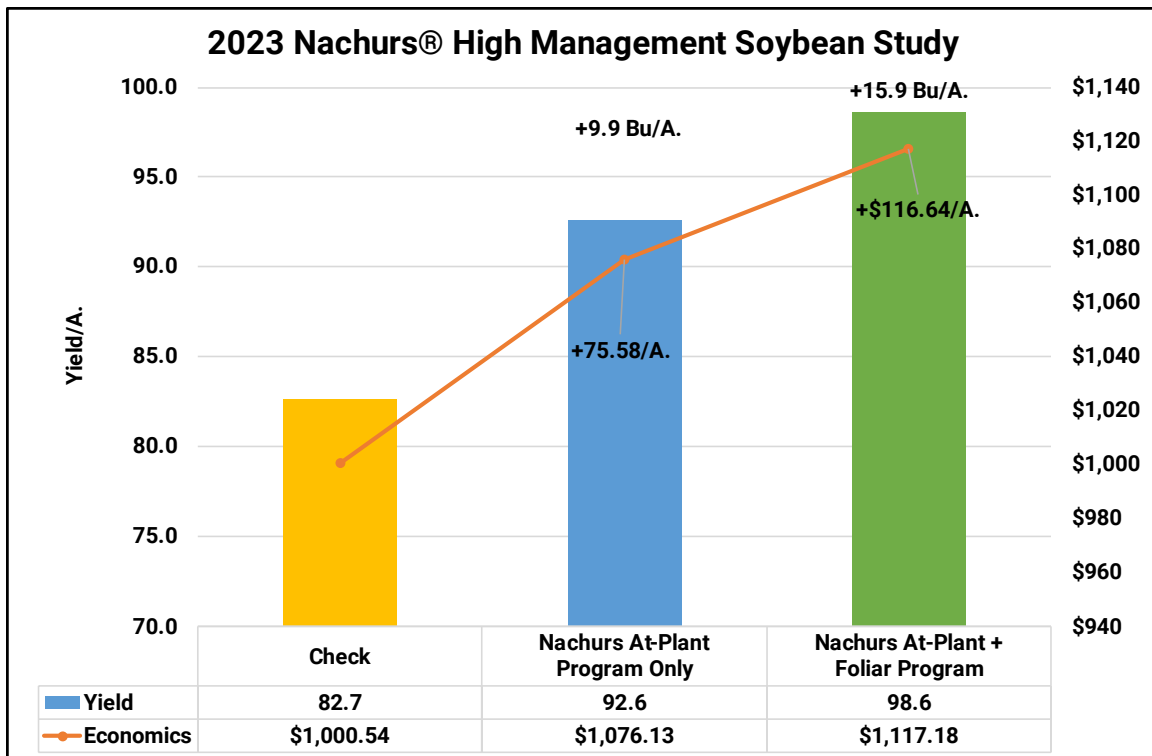
Figure 2. FurrowJet® Placement



Nachurs® High Management Study Continued

Results: The table below illustrates control treatments averaging 82.7 Bu/A. At-plant treatments achieved 92.6 Bu/A., +9.9 Bu/A. over the control. At-plant + foliar treatments offered yields of 98.6 Bu/A., +15.9 Bu/A. gains over the control and +4.0 Bu/A. over the stand-alone at-plant treatments.

Economics indicate at-plant treatments resulted in gains of +\$85.32/A., while at-plant and foliar treatments gained +\$5.15/A. additional positive returns with a net return of +\$90.47/A.



Planting Date: April 20th Variety: Asgrow 33XF3 Population: 120K Row Width: 30" Rotation: BAC SB Price: \$13.09

FurrowJet®: \$94.88/A Conceal® Program: \$41.13/A. Foliar Program: \$37.49/A. DAP/Potash: \$82/A.

AgroLiquid® High Management Irrigated Soybean Study

Objective: To evaluate the yield and economic impact of a soybean liquid starter fertilizer and foliar nutritional program from AgroLiquid in a high management irrigated environment. This trial consisted of the following:

Treatments and Placement:


Control:	R2 Miravis®Top, R5 Miravis®Neo	
At-Plant Fertility:		
FurrowJet® Tri-Band: (Figure 1.)	2 Gal/A. SpringUp® 0.5 Gal/A. Micro500™ 0.1 Gal/A. Manganese	3 Gal/A. Sure-K® 0.5 Gal/A. LiberateCa®
Conceal® Dual Band (Figure 2.)	2 Gal/A. Pro-Germ® 0.5 Gal/A. Micro500™ 0.1 Gal/A. Boron	3 Gal/A. Kalibrate® 0.5 Gal/A. LiberateCa® 0.1 Gal/A. Manganese
Foliar Applications:		
	V4: 0.125 Gal/A. Boron + Manganese, 1.5 Gal/A. Kapitalize®, 1.5 Gal/A. FertiRain®	
	R1: 1.5 Gal/A. Kapitalize® + 1.5 Gal/A. FertiRain® + 1Pt/A. Manganese	
	R5: 2 Gal/A. Nresponse™	

Figure 1. FurrowJet® Placement



Figure 2. Conceal® Dual Band Application



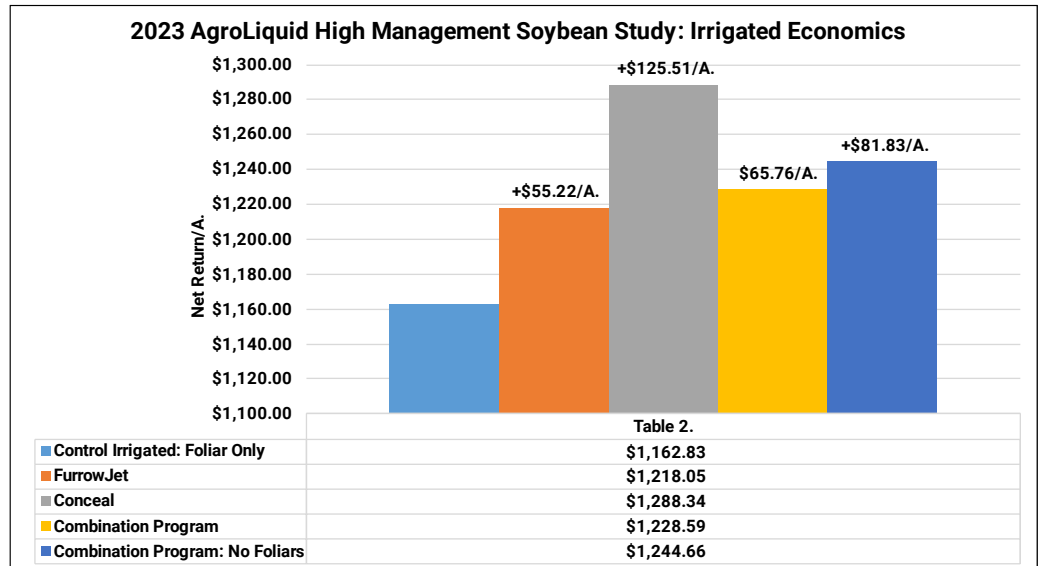
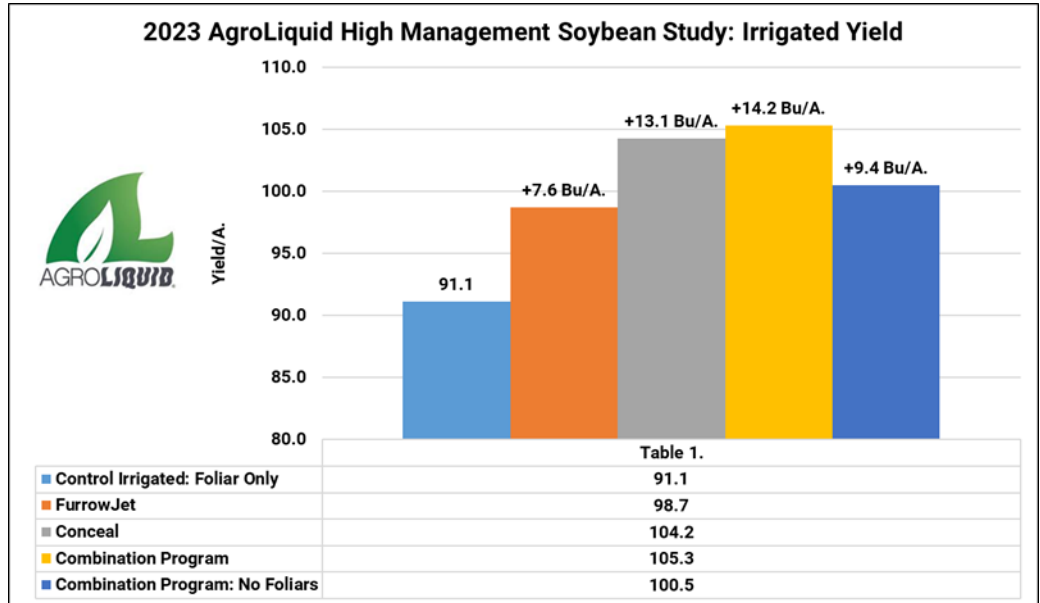
AgroLiquid® High Management Irrigated Soybean Study.

Results: Table 1. illustrates control treatments averaging 91.1 Bu/A. FurrowJet treatments resulted in yield gains of +7.6 Bu/A., while Conceal at +13.1 Bu/A. The combination of both FurrowJet, Conceal, and foliar programs offered the highest overall yield in the study at 105.3 Bu/A., +14.2 Bu/A. over the control.

Table 2. illustrates the economic response of all treatments. Individual Conceal treatments topped all programs with gains of +\$125.51/A.

FurrowJet treatments posted gains of +\$55.22/A., while combination FurrowJet/Conceal/Foliar treatments proved gains of +\$65.76/A.

Combination treatments, less foliar treatments tallied gains of +\$81.83/A.



Planting Date: April 13th Variety: Pioneer37A18E3 Population: 120K Row Width: 30" Rotation: BAC SB Price: \$13.09

FurrowJet@: \$76.28/A Conceal Program: \$73.83/A. Foliar Program: \$78.96/A. Fert Reallocation: \$30/A.

AgroLiquid® High Management Dryland Soybean Study

Objective: To evaluate the yield and economic impact of a soybean liquid starter fertilizer and foliar nutritional program from AgroLiquid in a high management irrigated environment. This trial consisted of the following:

Treatments and Placement:


Control:	R2 Miravis®Top, R5 Miravis®Neo	
At-Plant Fertility:		
FurrowJet® Tri-Band: (Figure 1.)	2 Gal/A. SpringUp® 0.5 Gal/A. Micro500™ 0.1 Gal/A. Manganese	3 Gal/A. Sure-K® 0.5 Gal/A. LiberateCa®
Conceal® Dual Band (Figure 2.)	2 Gal/A. Pro-Germ® 0.5 Gal/A. Micro500™ 0.1 Gal/A. Boron	3 Gal/A. Kalibrate® 0.5 Gal/A. LiberateCa® 0.1 Gal/A. Manganese
Foliar Applications:		
	V4: 0.125 Gal/A. Boron + Manganese, 1.5 Gal/A. Kapitalize®, 1.5 Gal/A. FertiRain®	
	R1: 1.5 Gal/A. Kapitalize® + 1.5 Gal/A. FertiRain® + 1Pt/A. Manganese	
	R5: 2 Gal/A. Nresponse™	

Figure 1. FurrowJet® Placement



Figure 2. Conceal® Dual Band Application



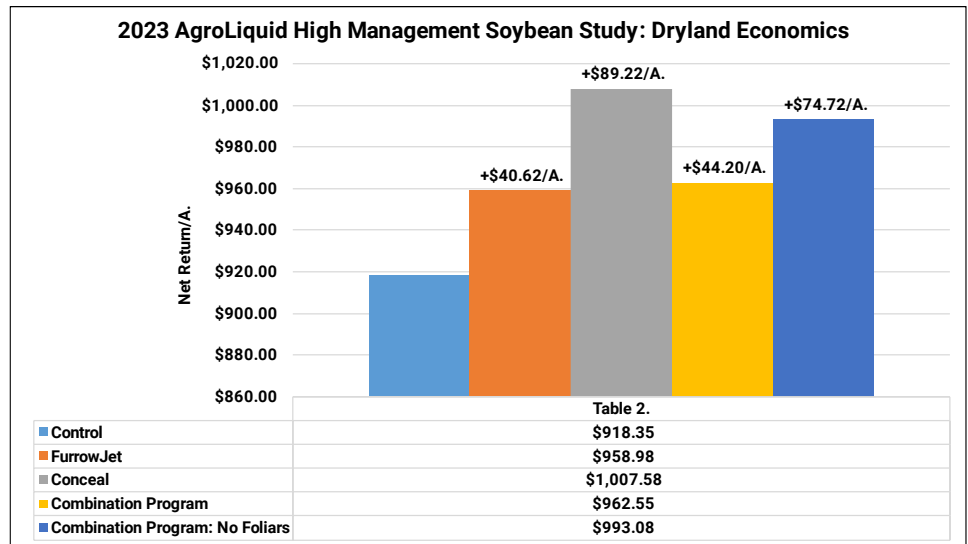
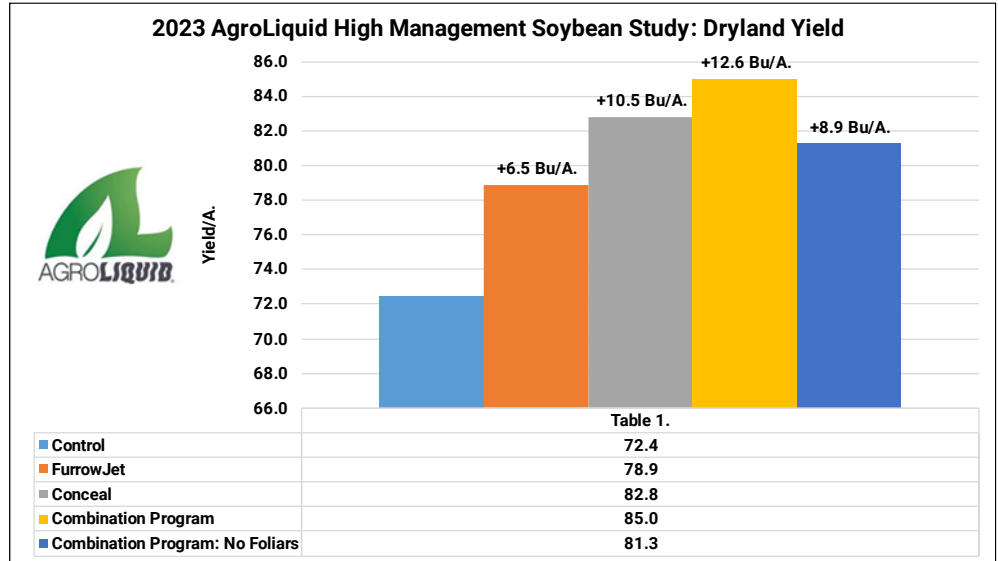
AgroLiquid® High Management Dryland Soybean Study.

Results: Table 1. illustrates control treatments averaging 72.4 Bu/A. FurrowJet treatments resulted in yield gains of +6.5 Bu/A., while Conceal at +10.5 Bu/A. The combination of both FurrowJet, Conceal, and foliar programs offered the highest overall yield in the study at 85.0 Bu/A., +12.6 Bu/A. over the control.

Table 2. illustrates the economic response of all treatments. Individual Conceal treatments topped all programs with gains of +\$89.22/A.

FurrowJet treatments posted gains of +\$40.62/A., while combination FurrowJet/Conceal/ Foliar treatments proved gains of +\$44.22/A.

Combination treatments, less foliar treatments tallied gains of +\$74.72/A.



Planting Date: April 13th Variety: Pioneer37A18E3 Population: 120K Row Width: 30" Rotation: BAC SB Price: \$13.09

FurrowJet@: \$76.28/A Conceal Program: \$73.83/A. Foliar Program: \$78.96/A. Fert Reallocation: \$30/A.

Irrigated vs Dryland FurrowJet®/Conceal® ROI Analysis

Objective: To evaluate the difference in return on investment of at-plant FurrowJet® and Conceal® (Figures 1-2.) nutritional programs in both irrigated and dryland environments.

It is a common question at the PTI Farm for growers to ask if the yield and economic response of at-plant treatments of FurrowJet® and Conceal® is similar in both irrigated, as well as dryland environments? This study evaluates the 2023 high yield corn management trials and isolates the difference in return on investment (ROI) of irrigated versus dryland programs.

Results: All treatments averaged near +9.0% to +9.6% positive return on investment, however dryland treatments actually offered greater than or equal to irrigated treatments at each fertility placement.

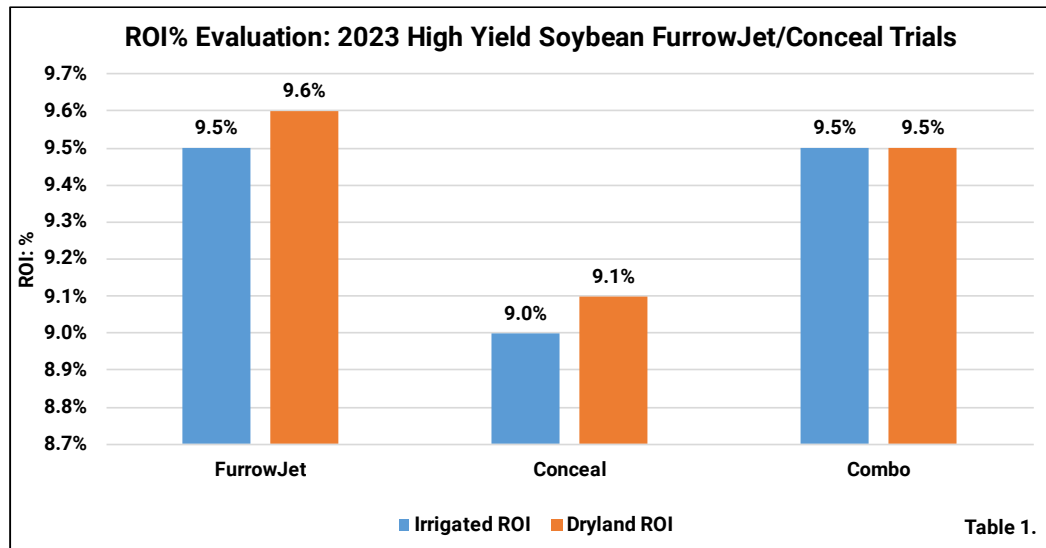


Figure 2. FurrowJet® Placement



Figure 1. Conceal® Placement



Marco Fertilizer High Management Soybean Study

Objective: To evaluate the yield and economic impact of a soybean liquid starter fertilizer and foliar nutritional program from Marco Fertilizer in a high management irrigated environment. This trial consisted of the following:

Treatments and Placement:


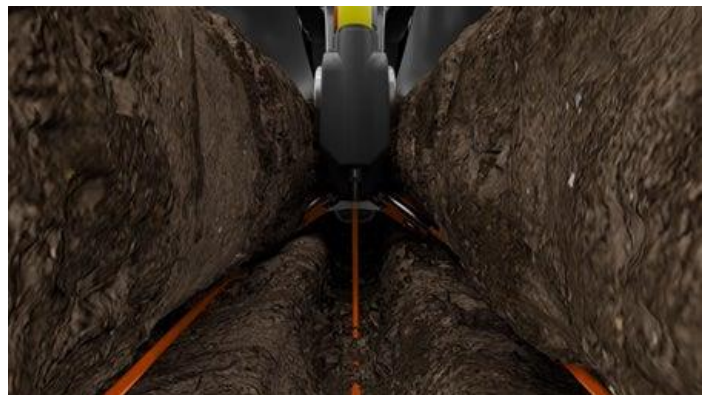
#1. Control:	Dryland, 100# 18-46-0, 100# 0-0-60
#2 At-Plant Fertility:	
Conceal® Dual Band (Figure 1.)	10 Gal/A. NutriStart BOOST 14-12-14-6S
FurrowJet® Wings: (Figure 2.)	3 Gal/A. NutriStart Complete, 3 Gal/A. Water Carrier
#3 Foliar Applications:	
	V3: 1# Foliar Complete 8-12-40, 1oz Poseidon, 1Pt Energizer, 0.5 Pt Iron Plus
	R2: 2# Foliar Complete 8-12-40, 2oz Poseidon, 1Pt Energizer
	R4: 2# Foliar Complete 8-12-40, 1 Pt Energizer

Figure 1. Conceal® Placement



Figure 2. FurrowJet® Placement

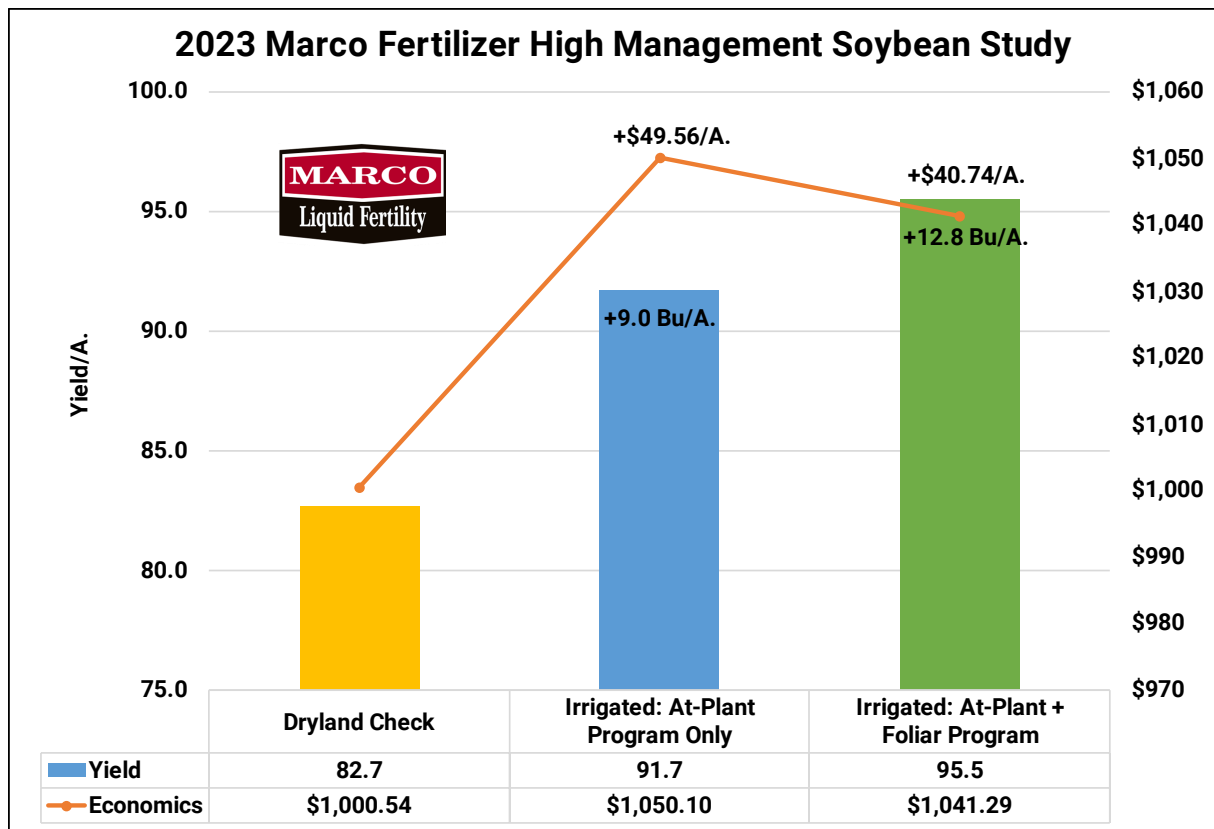


Marco Fertilizer High Management Soybean Study Continued

Irrigated treatments received 5.00" of rain throughout the growing season, and all treatments received fungicide applications of 13.7oz/A. Miravis® Top at R1 and 13.7oz/A. of Miravis®Neo at R3 growth stages. Control treatments received 100# DAP and 100# Potash for its dry fertility program.

Results: At-Plant FurrowJet® and Conceal® treatments resulted in yields of 91.7 Bu/A., +9 Bu/A. over the control. At-plant + foliar combination treatments pushed yield to 95.5 Bu/A., +12.8 Bu/A. over the control.

After all costs, at-plant nutritional treatments proved economic gains of +\$49.56/A. Adding the foliar treatments to at-plant applications tallied economic gains of +\$40.74/A.



Planting Date: April 20th Variety Asgrow 33FX3 Population: 120K Row Width: 30" Rotation: BAC SB Price: \$13.09 Irrigation: \$40/A.

FurrowJet® Wings: \$29.25/A. Conceal® Program: \$41/A. Foliar Program: \$58.56/A. 100# DAP,100# Potash: \$82/A.

Stoller® USA Fertilizer High Management Soybean Study

Objective: To evaluate the yield and economic impact of a soybean liquid starter fertilizer and foliar nutritional program from StollerUSA in a high management irrigated environment. This trial consisted of the following:

Treatments and Placement:


#1. Control:	Dryland, 100# 18-46-0, 100# 0-0-60
#2 At-Plant Fertility:	
FurrowJet® Center: (Figure 1.)	4oz/A. Fortified Stimulate Yield Enhancer® Plus + 4oz/A. BioForge Advanced™, 3 Gal/A. water carrier
FurrowJet® Wings: (Figure 1.)	8oz Energy Power®
Conceal® Dual Band: (Figure 2.)	32oz/A. Harvest Plus™, 8 Gal/A. water carrier
#3 Foliar Applications:	
	V3: 8oz Xcyte™, 8oz Bio-Forge® Advanced, 32oz Harvest Plus®
	R1: 2oz/A. Stimulate®RC, 16oz/A. Energy Power®
	R2: 8oz Xcyte™, 2.5#/A. Harvest More® UreaMate, 1 Qt/A. Sugar Mover®
	R3: 8oz/A. Xcyte™, 2.5#/A. Harvest More® UreaMate
	R4: 1 Qt/A. Harvest Plus™, 8oz/A. Xcyte™
	R5: 8oz/A. Xcyte™ 2.5#/A. Harvest More® Urea Mate

Figure 1. FurrowJet® Placement



Figure 2. Conceal® Dual Band Placement

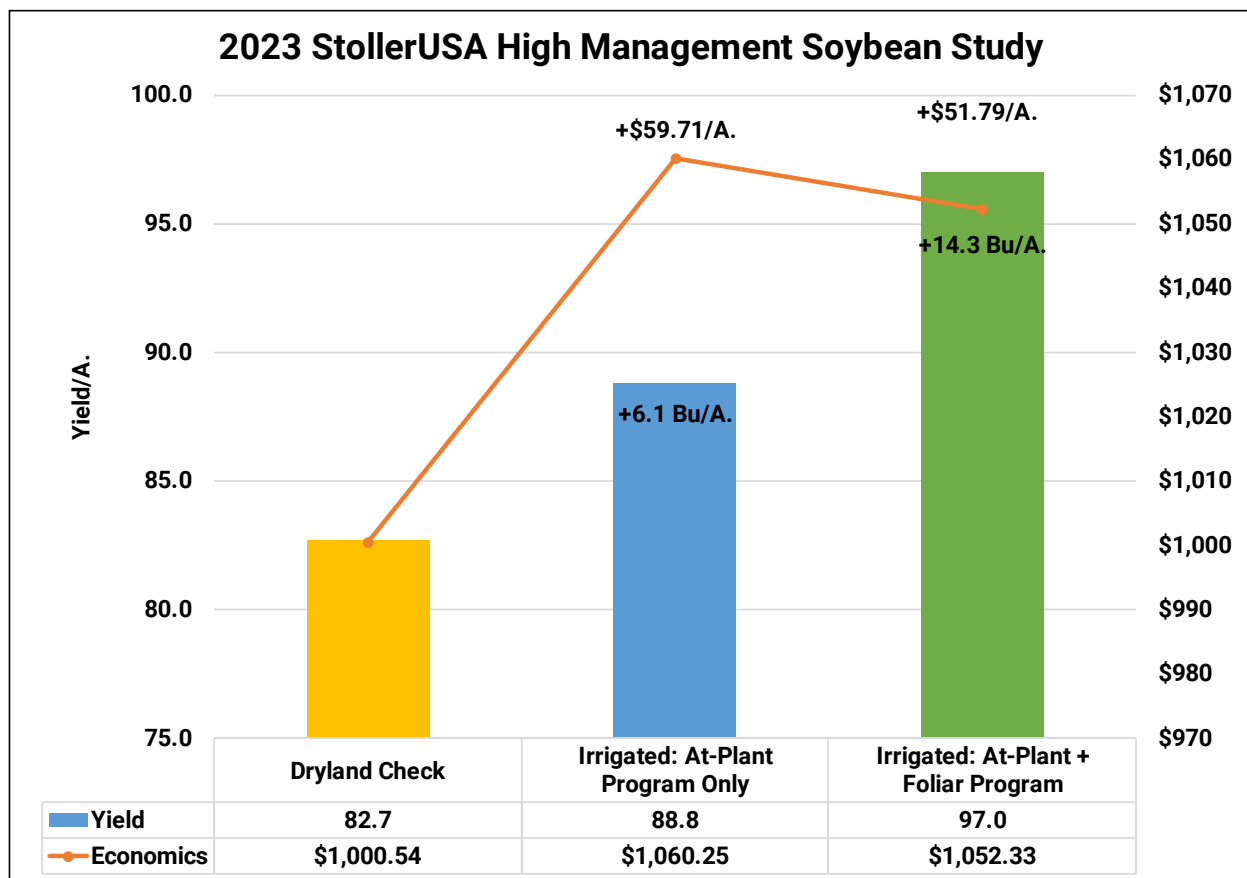


Stoller® USA Fertilizer High Management Soybean Continued

All treatments received 5.00" of rain throughout the growing season as well as fungicide applications of 13.7oz/A. Miravis® Neo at R1 and 13.7oz/A. of TrivaPro® at R3 growth stages.

Results: At-Plant treatments resulted in yields of 88.8 Bu/A., +6.1 Bu/A. over the control. At-plant + foliar combination treatments pushed yield to 97.0 Bu/A., +14.3 Bu/A. over the control.

After all costs, at-plant nutritional treatments proved economic gains of +\$59.71/A., while the foliar/at-plant combination treatments tallied returns of +\$51.79/A.



Planting Date: April 20th Variety Asgrow 33FX3 Population: 120K Row Width: 30" Rotation: BAC SB Price: \$13.09 Irrigation: \$40/A.

FurrowJet® Wings: \$21.14/A. Conceal® Program: \$41/A. Foliar Program: \$115.26/A. 100# DAP,100# Potash: \$82/A.

NewFields Ag™/NMS High Management Soybean Study

Objective: To evaluate the yield and economic impact of a soybean liquid starter fertilizer and foliar/biological nutritional program from NewFields Ag and Nutrient Management Specialists (NMS) in a high management non-irrigated environment. This trial consisted of the following:

Treatments and Placement:

#1. Control:	200# DAP, 200# 0-0-60, Less R3 Fungicide, Less 40# N	
#2 At-Plant Fertility:	Terrasym 401 + DUST: Hopper Box Treatment	
FurrowJet® Center: (Figure 1.)	16oz/A. Rizosphere:	Microbial Fermentation Manure/Kelp
	16oz/A. Phenom®:	Endophyte Bacterial N Efficiency
	16oz/A. SoyFx™:	Bacteria, Archaea, and Fungi
	NMS Mix:	Fish, Kelp, Sea Crop
FurrowJet® Wings: (Figure 1.)	16oz/A. Frenzy™:	Antioxidant Enzyme/Stress Mitigation
	NMS Mix:	Moly, Biologicals, Zn/Mn SO4 32%
Conceal® Dual Band: (Figure 2.)	NMS Mix:	20 Gal/A. 9-45-16 w/micros
#3 Foliar Applications:	16oz/A. V4:	DB25 Frenzy
	NMS Mix: VT+R3:	26-8-16 w/micros + biologicals

Figure 1. FurrowJet® Placement



Figure 2. Conceal® Dual Band Placement

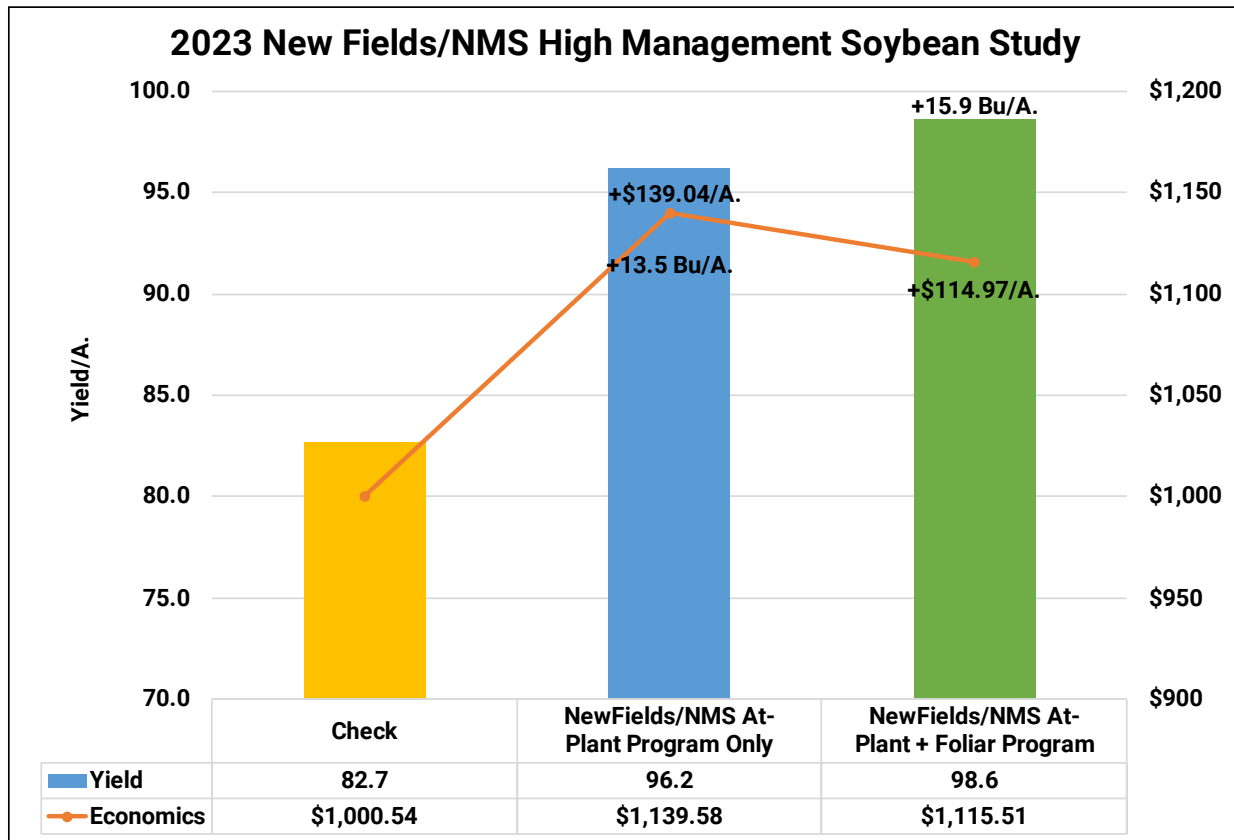


NewFields Ag™/NMS High Management Soybean Study

All treatments received 5.00" of rain throughout the growing season as well as fungicide applications of 13.7oz/A. Miravis® Neo at R1 and 13.7oz/A. of TrivaPro® at R3 growth stages.

Results: At-Plant treatments resulted in yields of 96.2 Bu/A., +13.5 Bu/A. over the control. At-plant + foliar combination treatments pushed yield to 98.6 Bu/A., +15.9 Bu/A. over the control.

After all costs and application, at-plant nutritional treatments proved economic gains of +\$139.04/A., while the foliar/at-plant combination treatments tallied returns of +\$114.97/A.



Planting Date: April 20th Variety Asgrow 33FX3 Population: 120K Row Width: 30" Rotation: BAC SB Price: \$13.09 Irrigation: \$40/A.

At-Plant Program: \$79.68/A. Foliar Program: \$135.16/A. 100# DAP,100# Potash: \$82/A.

Ocean Blue Ag Soybean High Management Study

Objective: To evaluate the yield and economics of Ocean Blue Ag’s soybean nutrition program. This high management fertility study implements the use pre-plant dry calcium, sea salt, at-plant FurrowJet® and Conceal® liquid nutrition, as well as foliar liquid applications at V3, VT, and R1 growth stages.

Sea-90™ by SeaAgri, Inc are natural salt crystals produced from sea water mined from the Sea of Cortez in Mexico. It is dehydrated seawater in its purest state containing 75-80 percent sodium chloride containing 90 plus elements including sodium, potassium, calcium, and magnesium and balanced with trace elements including copper, chromium, zinc, manganese, selenium, cobalt, molybdenum.

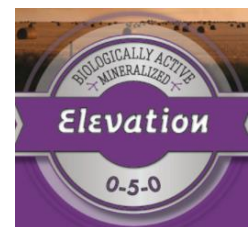


Elevation 0-5-0 is an early V3 foliar feed that contains long lasting bio-stimulated catalyst and phosphoric acid that helps pollination, blossom retention and fruiting.

IPS 100 is a superior non-ionic, surfactant, spreader sticker, and soil penetrant mixed in a proprietary nutrient complex base performing various functions in agriculture. It is also a superior penetrant to help loosen tight soils allowing better aeration and water movement in the root zone.



Nutri-Shield 0-7-0 is applied in-furrow and contains vitamin hormone enzymes, rooting acids, chelated trace minerals, and humic acids. It helps provide for immediate growth energy, promotes stronger roots and suppresses insect feeding.



Ocean Blue Ag Fertility High Management Study

The following treatments were made as a part of a sequential step-up program to help evaluate single applied programs as well as combination programs:

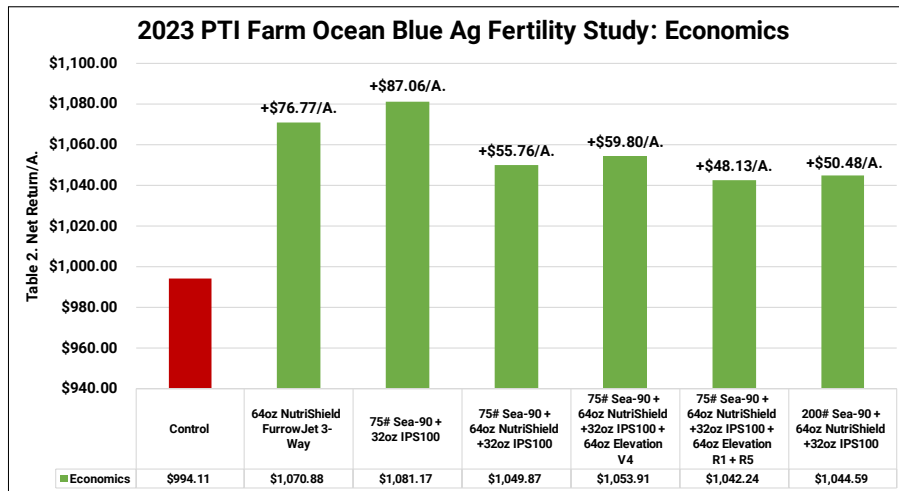
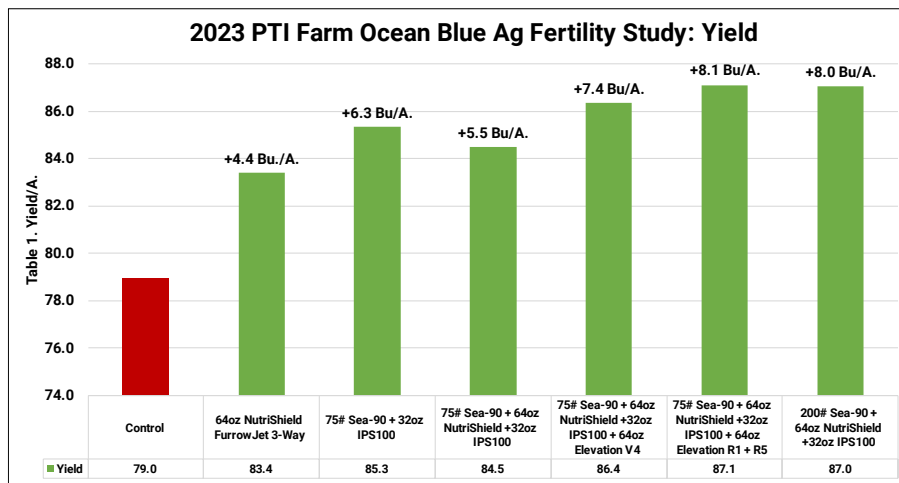
<u>Program</u>	<u>Treatment</u>	<u>Application Timing</u>	<u>Placement of Fertilizer</u>
1	Control	None	None
2	64oz Nutri-Shield FurrowJet®	At-Plant in Furrow	FurrowJet® Tri-Band
3	75# Sea-90 32oz IPS 100	Pre-Plant Pre-Plant	Broadcast Spinner Pre-Broadcast Spray
4	64oz Nutri-Shield FurrowJet® 75# Sea-90 32oz IPS 100	At-Plant In-Furrow Pre-Plant Pre-Plant	FurrowJet® Tri-Band Broadcast Spinner Pre-Broadcast Spray
5	64oz Nutri-Shield FurrowJet® 75# Sea-90 32oz IPS 100 64oz Elevation	At-Plant In-Furrow Pre-Plant Pre-Plant V4	FurrowJet® Tri-Band Broadcast Spinner Pre-Broadcast Spray Foliar Broadcast Spray
6	64oz Nutri-Shield FurrowJet® 75# Sea-90 32oz IPS 100 64oz Elevation	At-Plant In-Furrow Pre-Plant Pre-Plant R1, R5	FurrowJet® Tri-Band Broadcast Spinner Pre-Broadcast Spray Foliar Broadcast Spray
7	64oz Nutri-Shield FurrowJet® 200# Sea-90 IPS 100	At-Plant In-Furrow Pre-Plant Pre-Plant	FurrowJet® Tri-Band Broadcast Spinner Pre-Broadcast Spray

*All treatments received foliar treatment of fungicide at R3 growth stage.

Ocean Blue Ag Fertility High Management Study Continued

Results: Table 1. summarizes all Ocean Blue Ag products proved positive yield gains ranging from +4.4 to +8.1 Bu/A. Between all 6 of the treatments, there was only a 3.5Bu/A. spread, thus having similar yields across the different programs.

Table 2. illustrates the telling story around the economics of the treatments. While all treatments provided positive yield gains, they all provided positive net return on investment as well. The first two treatments proved high net returns of +\$76.77/A., and +\$87.06/A. respectively. This was due to the lower cost of the product being used in those treatments. The last 4 treatments resulted in yield gains like those of the first 2, but due to a higher cost of overall product, they resulted in a little lower net return. Those being +\$55.76/A, +\$59.80/A, +\$48.13/A., and +\$50.48/A respectively.



Planting Date: May 18th Variety: GH 3724XF Population: 120K Row Width: 30" Rotation: BAC SB Price: \$13.09 \$40 Fertilizer Reallocation

SandyCal Aragonite: \$31.86/A. IPS: \$12.41/A. NutriShield: \$20.83/A IPS 100: \$12.41/A. Elevation: \$20.83/A. Sea-90: \$610/Ton

Marco Fertilizer NutriStart BOOST 14-12-4-6S Study

Objective: This trial evaluates the yield and net return of Conceal® system dual band treatments of NutriStart BOOST 14-12-12-4-6S at 10, 15, and 20 Gal/A. rates. This liquid fertilizer is a 70% polyphosphate and 30% orthophosphate formula designed for non-in furrow applications in soybeans. NutriStart products are manufactured with Marco 10-34-0, Potassium - soluble potash (K2O), Sulfur - Ammonium Thiosulfate.



Conceal® is an ideal placement for this product as its far enough away from the seed furrow to prevent seed injury, yet close enough to enable access to seedling nutrition (Figure 1).

Results: Table 1. illustrates that all rates of 14-12-4-6S proved positive yield gains from +4.6 to +5.5 Bu/A., however 10 Gal/A. provided the economic optimum rate resulting in a positive return on investment of +\$56.15/A.

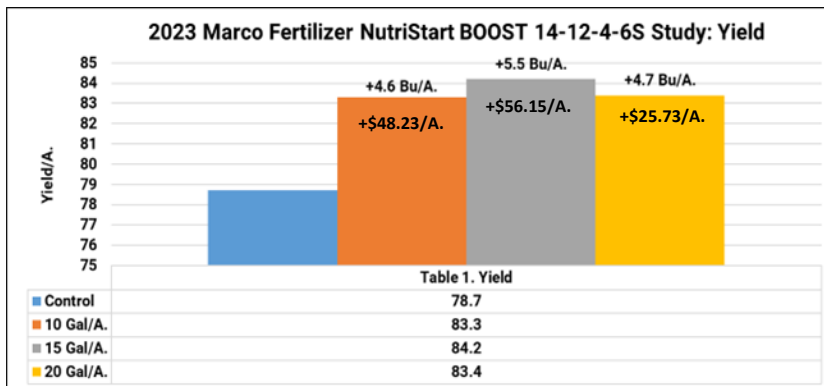


Table 2. reveals long-term multi-year economics during 2018-2023. Over this 6-year period, economic optimum has occurred at the 15 Gal/A. rate of NutriStart BOOST with an average return on investment of +\$46.88/A. 10Gal/A. has also provided gains of +\$43.70/A.

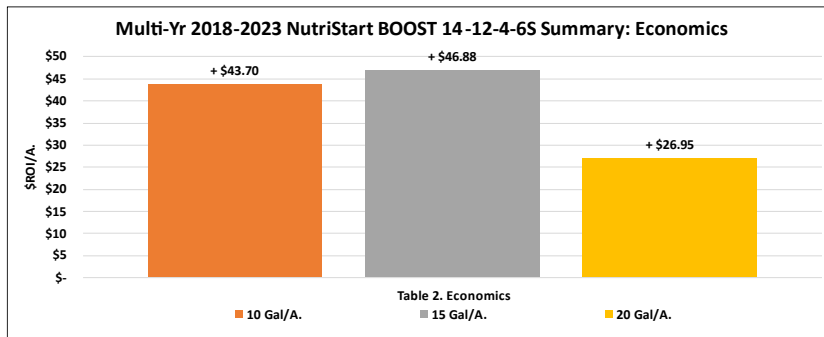


Figure 1. Conceal® Dual Placement



Planting Date: April 24th Variety: AG 35FX3 Population: 120K Row Width: 30" Rotation: BAC SB Price: \$13.09

BOOST 14-12-4-6: \$4.10/Gal

Fert Reallocation: \$30

Aqua-Yield® NanoCS® FurrowJet® Study

Objective: To evaluate yield and economics of NanoCS® by AQUA-YIELD. NanoCS® is a starter fertilizer enhancer with a robust combination of NanoShield® Technology, balanced NPK, Zinc, and Bio Stimulant. Aqua-Yield products contain nanoparticles that penetrate cell walls and creates a nano-sized shield around nutrient/molecules/ions. This technology delivers essential nutrients into the seed for rapid germination and growth.

This trial aims to establish the efficiency of Aqua-Yield’s NanoCS® nano-liquid based fertility product in tandem with NACHURS® Triple Option® (3-10-13-1S-0.01Zn) in-furrow starter fertilizer. Performance of a 50% rate reduction (2 Gal/A.) of Triple Option is then compared to the 100% rate (4 Gal/A).

NanoCS® was applied in-furrow at planting in a FurrowJet® center only application (Figure 1).

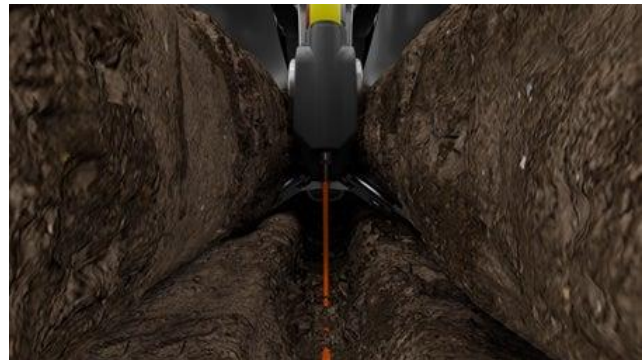
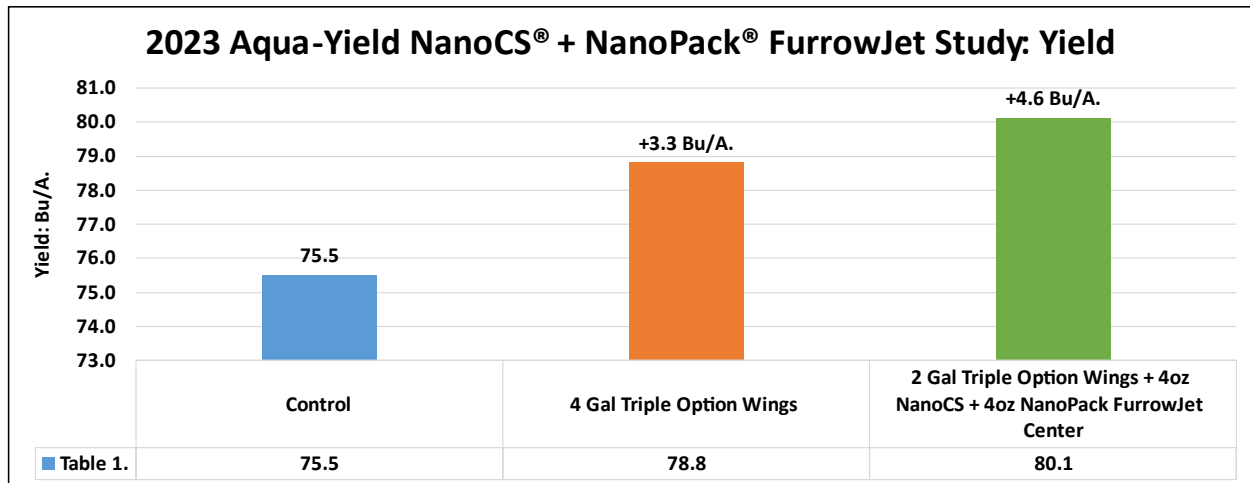


Figure 1: FurrowJet® In-Furrow Application



AQUA-YIELD®

NanoCS™

Aqua-Yield® NanoCS® FurrowJet® Study Continued

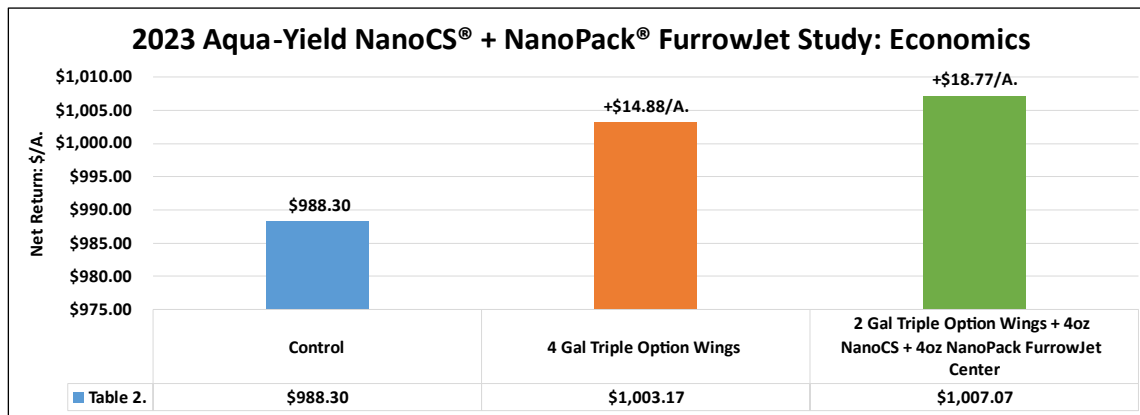
Results: Table 1. illustrates yield results of all treatments. The control treatment brought yields of 75.5 Bu/A. The 100% rate treatment at 4 Gal/A. of Triple Option resulted in yields of +3.3 Bu/A.

Aqua-Yield’s NanoCS® tank-mixed with 50%(2Gal) Triple Option rates resulted in +4.6 Bu/A. yield improvement over the control treatment.



Table 2. illustrates the overall economics of the fertility study. Reducing in-furrow applications by 50% and tank-mixing NanoCS® resulted in economic gains of +\$18.77/A.

As farmers, we are always interested in the ability to reduce fertilizer rates without sacrificing yield or profitability and we look forward to testing this product for a fourth year in 2024.



NACHURS® Triple Option® FurrowJet® Trial

Objective: To evaluate the effect on yield and economics when NACHURS Triple Option® 4-13-17-1S starter fertilizer (Figure 2.) is placed at 2 and 4 Gal/A. in FurrowJet® **wing** only configurations (Figure 1). NACHURS Triple Option® is a premium 100% orthophosphate in-furrow liquid fertilizer that contains NACHURS bio-K® technology.

Figure 1. FurrowJet® Placement

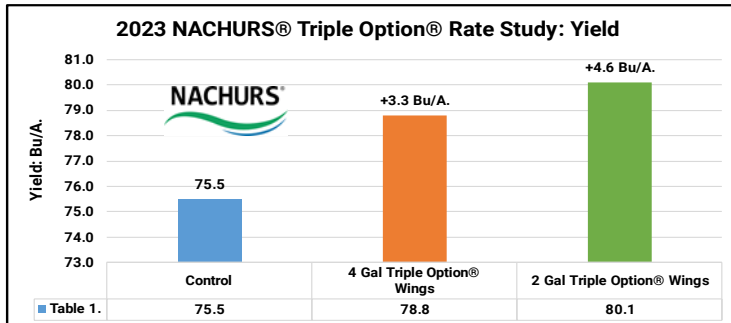
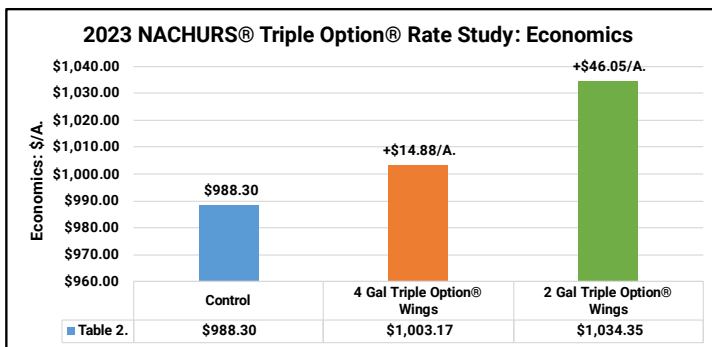



Figure 2. Nachurs Triple Option® Starter





NUTRIENTS SUPPLIED (pounds per gallon):

Total Nitrogen (N).....0.45
 Available Phosphate (P₂O₅).....1.46
 Soluble Potash (K₂O).....1.91
 Sulfur (S).....0.11

Derived from: Urea, Ammonium Hydroxide, Ammonium Thiosulfate, Phosphoric Acid, Potassium Hydroxide, and Potassium Acetate.

PRODUCT PROPERTIES:

Analysis:.....4-13-17-1S
 Weight:.....11.25 lbs. per gallon
 Specific gravity:.....1.35 kg/L
 pH:.....7.0–7.6
 Appearance:.....Nearly colorless

Results: Table 1. illustrate rates of Nachurs Triple Option® 4-13-17-1S at 2 Gal/A. achieved agronomic optimum rate with yield gains of +4.6 Bu/A. The 4 Gal/A. rate achieved a yield increase of +3.3 Bu/A.

Table 2. illustrates economics of this study, the 2 Gal/A. rate was the economic optimum, with a return on investment of +\$46.05/A. 4 Gal/A rate also proved profitable, with a return on investment of +\$14.88/A.

Xyway® LFR® FurrowJet® Study

Objective: To evaluate the yield and economic return of Xyway® LFR®, a fungicide with the active ingredient Flutriafol (Figure 1). Xyway® LFR® fungicide is promoted as a revolutionary at-plant fungicide formulation that provides season-long disease protection from the inside out, root, stalk, and leaf.



Figure 1.

EPA Reg. No. 279-9638	EPA Est. No. 279-DE-001
Active Ingredient:	By Wt.
Flutriafol	26.4%
Other Ingredients:	73.6%
TOTAL:	100.0%

Contains 2.5 pounds per gallon of the active ingredient flutriafol. Suspension Concentrate.

This study evaluates Xyway® LFR® applied in various soil applied situations. First, Xyway® LFR® is evaluated as an in-furrow treatment applied through FurrowJet®, a planter fertilizer attachment that enables placement of fertilizer on the seed as well as 3/4" on each side of the seed (Figure 2-3). To achieve this dual-band placement, the wings on FurrowJet® system angle downward to cut into the sidewall and place fertilizer alongside the seed in a dual-band. By doing this, lifting and fracturing can occur that potentially could remove soil smearing or compaction created by disc openers.

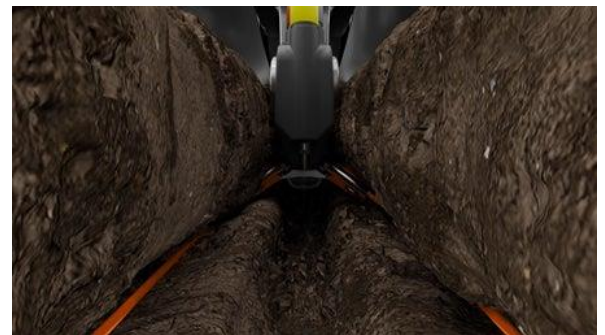


Figure 2. FurrowJet® Wing Placement

In this study, Xyway® LFR® is evaluated in one FurrowJet® placement consisting of: FurrowJet® Wings only (Figure 2.) Secondly, to focus on applications of Xyway® LFR® further away from the seed, a second treatment was also evaluated with Conceal®. A Conceal® system is a unique planter attachment that allows growers to place product in a high concentration dual or single band positioned 3" away from the seed trench (Figure 5.) in depths near 1.5". The Conceal® system uses existing planter space, utilizing a backswept knife located within the center of the planter's gauge wheels (Figure 4). As product is applied, it is sealed within the soil profile by the gauge wheels.

Figure 3. FurrowJet® In-Furrow Planter Attachment



Figure 4. Conceal Knife Design within Gauge Wheel

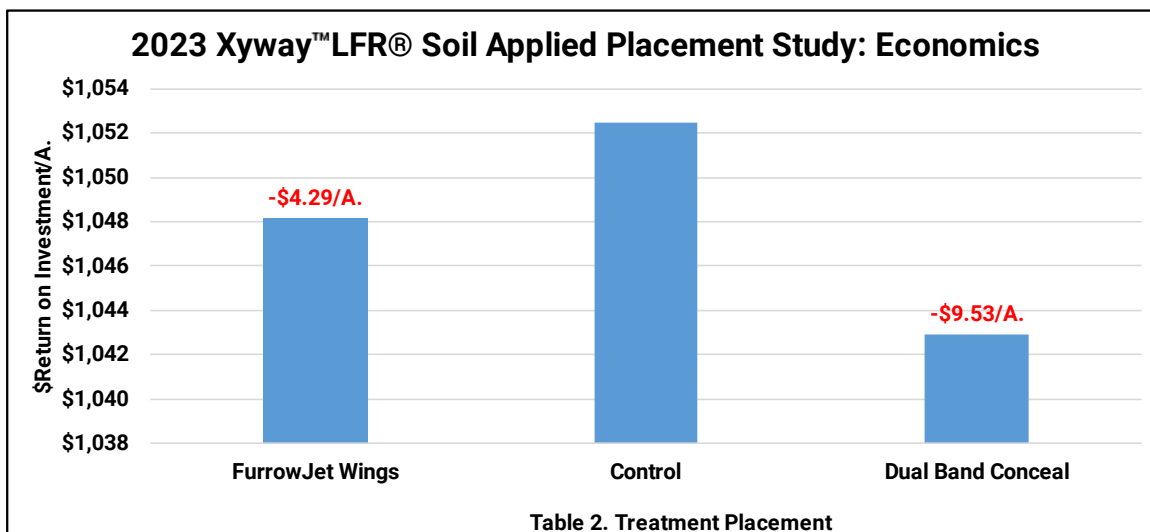
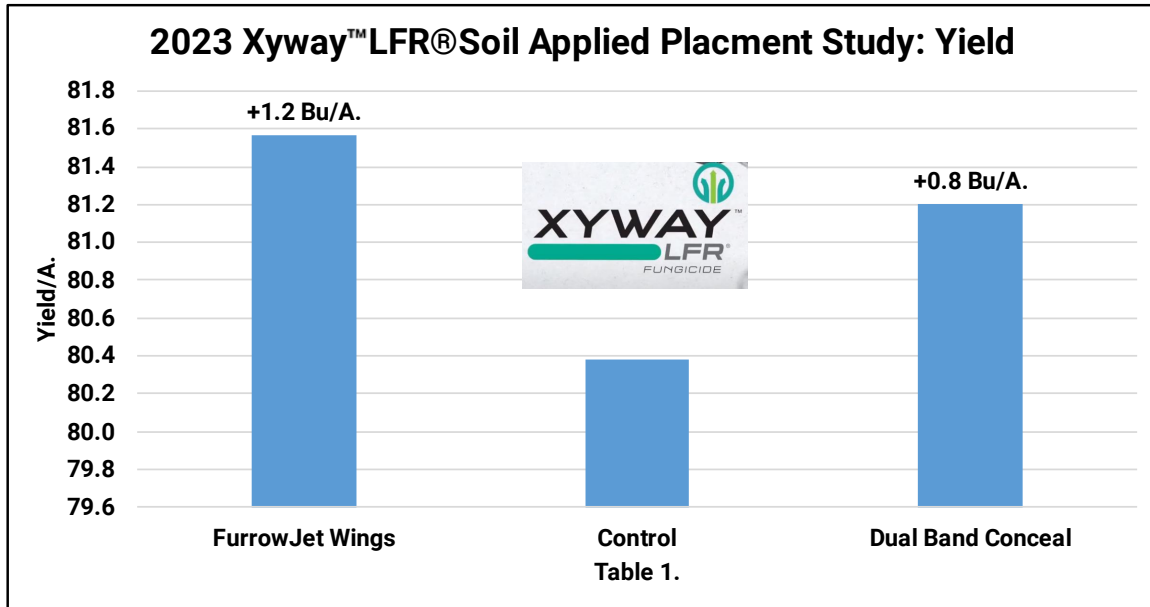


Figure 5. Conceal Dual Placement 3" from Seed Trench



Xyway® LFR® FurrowJet® Study Continued

Results: Table 1. illustrates all treatments did in fact result in positive yield gains. As flutriafol was placed outside of the seed trench, FurrowJet® wings offered the trial’s highest yield gains at +1.2 Bu/A. and Conceal® placements resulted in gains of +0.8 Bu/A. Although these treatments had higher yield, they did result in an overall return on investment of **-\$4.29/A.** and **-\$9.53/A.**



Zironar™ FurrowJet® Study

Objective: To evaluate the yield and economic return of Zironar™. Zironar™ bio fungicide is promoted as a season long root colonizing biological that protects against crucial fungal diseases and soil nematodes.



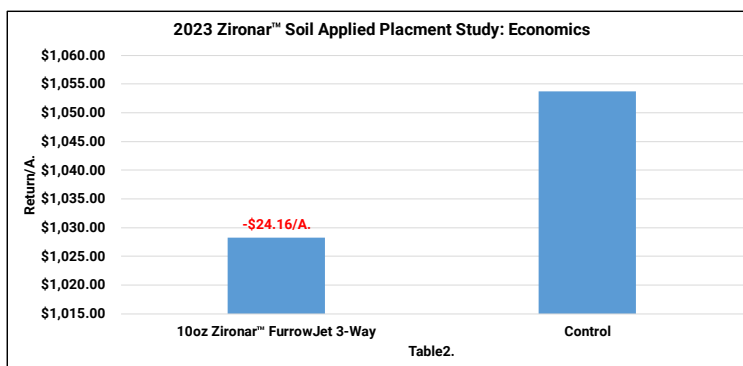
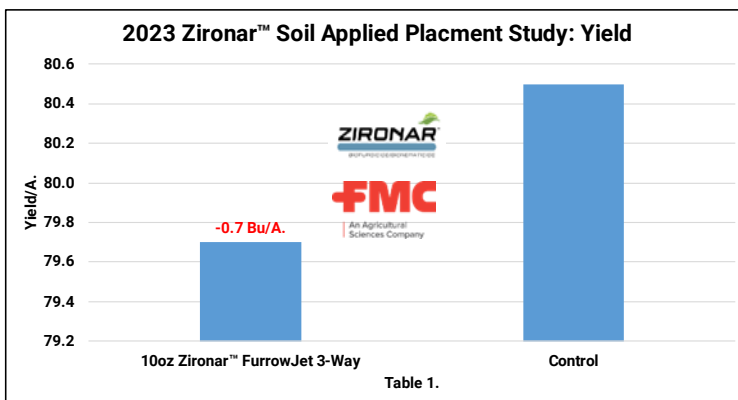
A biological fungicide/nematicide for in-furrow use for early season protection against listed fungal diseases and soil nematodes.

This study evaluates Zironar™ applied in various soil applied situations. First, Zironar™ is evaluated as a in-furrow treatment applied through FurrowJet®, a planter fertilizer attachment that enables placement of fertilizer on the seed as well as 3/4" on each side of the seed (Figure 1). To achieve this dual-band placement, the wings on FurrowJet® system angle downward to cut into the sidewall and place fertilizer alongside the seed in a dual-band.

EPA Reg. No. 279-3618	EPA Est. No. 279-NY-1
ACTIVE INGREDIENTS:	By Wt.
Bacillus licheniformis strain FMCH001*	3.50%
Bacillus subtilis strain FMCH002**	4.00%
OTHER INGREDIENTS:	92.50%
	100.00%

*Contains a minimum of 2.3 X 10¹⁰ colony-forming units (cfu) per milliliter of product.
 **Contains a minimum of 2.3 X 10¹⁰ colony-forming units (cfu) per milliliter of product.
 This product contains a total of 0.73 pound of active ingredients per gallon.

Results: Table 1. illustrates that when Zironar™ was applied in FurrowJet® wings it resulted in yield losses of **-0.7 Bu/A.** and economic losses of **-\$24.16/A.**



Zironar™ FurrowJet® PTI Partner Study

Objective: To evaluate the yield and economic return of Zironar™. Zironar™ bio fungicide is promoted as a season long root colonizing biological that protects against crucial fungal diseases and soil nematodes.

This study evaluates Zironar™ applied in various soil applied situations. First, Zironar™ is evaluated as a in-furrow treatment applied through FurrowJet®, a planter fertilizer attachment that enables placement of fertilizer on the seed as well as 3/4" on each side of the seed (Figure 1). To achieve this dual-band placement, the wings on FurrowJet® system angle downward to cut into the sidewall and place fertilizer alongside the seed in a dual-band.

Results: Table 1. illustrates that when Zironar™ was applied in FurrowJet® wings it resulted in yield gains of +0.5 Bu/A. but economic losses of **-\$8.45/A.**

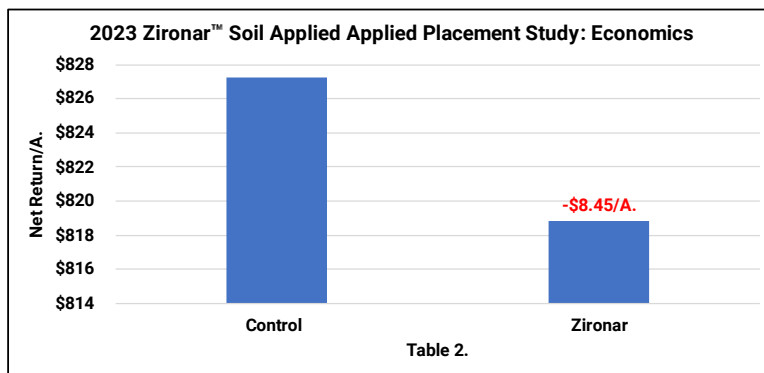
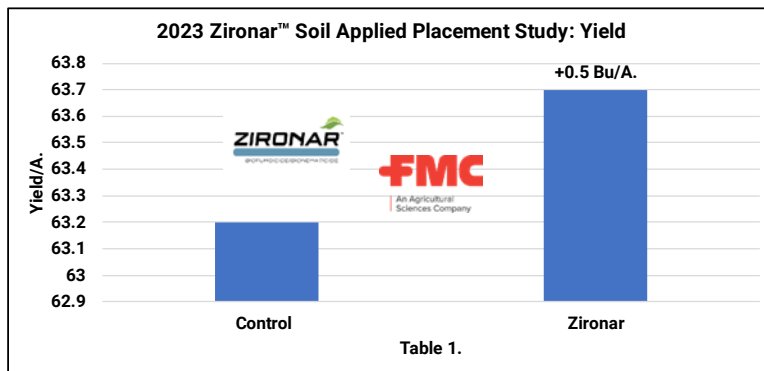
This trial was done as a PTI partner trial, implemented by Pfiefer Farms in Mazon, IL.



A biological fungicide/nematicide for in-furrow use for early season protection against listed fungal diseases and soil nematodes.

EPA Reg. No. 279-3618	EPA Est. No. 279-NY-1	By Wt.
ACTIVE INGREDIENTS:		
<i>Bacillus licheniformis</i> strain FMCH001*		3.50%
<i>Bacillus subtilis</i> strain FMCH002**		4.00%
OTHER INGREDIENTS:		92.50%
		100.00%

*Contains a minimum of 2.3 X 10¹⁰ colony-forming units (cfu) per milliliter of product.
 **Contains a minimum of 2.3 X 10¹⁰ colony-forming units (cfu) per milliliter of product.
 This product contains a total of 0.73 pound of active ingredients per gallon.



FurrowJet® Side-Wall Study

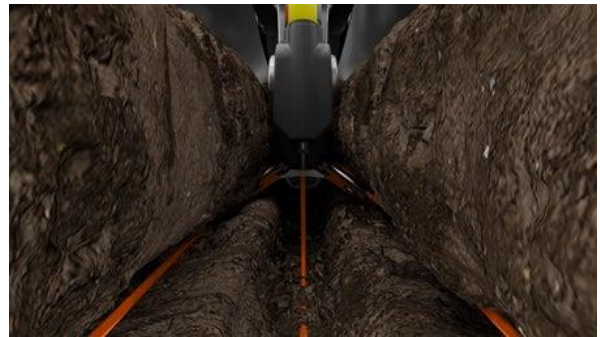
Objective: FurrowJet® system is a planter fertilizer attachment (Figure 1.) that enables placement of not only an in-furrow starter fertilizer, but also a dual-band of fertilizer 3/4" on each side of the seed. To achieve this dual-band placement, the wings on FurrowJet® system angle downward to cut into the sidewall and place fertilizer alongside the seed in a dual-band. By doing this, lifting and fracturing can occur that potentially could remove soil smearing or compaction created by disc openers. Additionally, closing wheel systems following FurrowJet® wings have a better opportunity to close the seed trench, remove air pockets, and allow for good seed-to-soil contact.



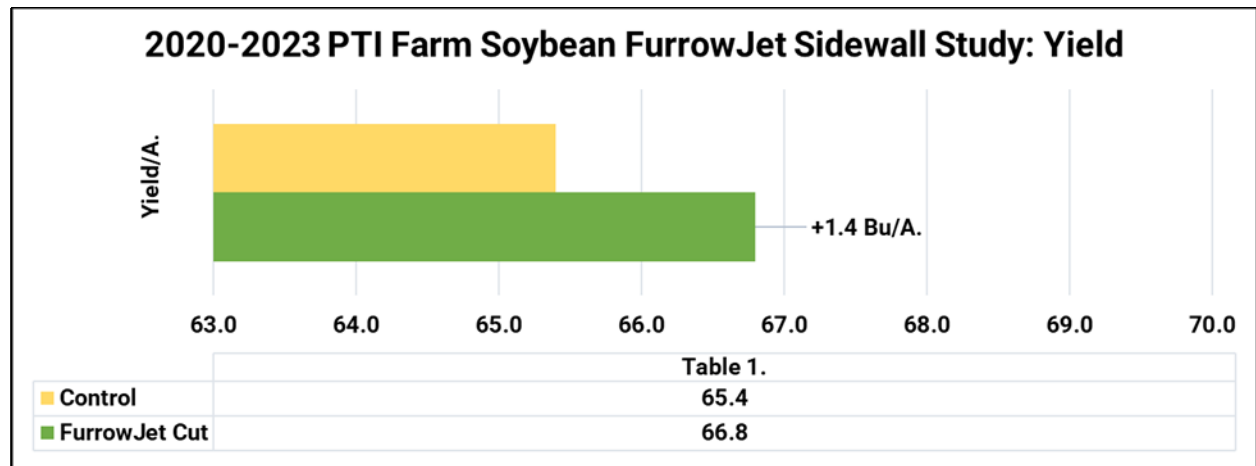
Figure 1. FurrowJet®

This study evaluates FurrowJet® dual-band wings offering the ability to cut, lift and remove side-wall compaction in the seed furrow (Figure 2). For this study, no liquid fertilizer was applied.

Figure 2: FurrowJet® Dual-Band Wings Fracturing Sidewalls



Results: In 2023, FurrowJet® alleviating sidewall density resulted in +1.0 Bu/A. average yield gains. Table 1. below illustrates multi-year data over 2020-2023 with average yield gain of +1.4 Bu/A. Using a soybean commodity price of \$13.09 and a cost of \$320/Row for FurrowJet® systems, break-even would occur on a 16-row planter with this scenario at 280 acres, not even considering any liquid fertilizer potential benefit.



Soybean Summary of 2023 FurrowJet® Applications

PTI Farm Study	Bu/A.	ROI\$/A.
Soybean Plant Date with Starter: April 13th	9.5	\$92.02
Soybean Plant Date with Starter: May 18th	9.5	\$92.02
Soybean Plant Date with Starter: March 30th	8.2	\$75.00
Soybean Plant Date with Starter: April 24th	6.3	\$50.13
2 Gal Triple Option	4.6	\$46.05
Aqua-Yield NanoCS + NanoPack + 2 Gal Triple Option	4.6	\$18.77
4 Gal Triple Option	3.3	\$14.88
FurrowJet Sidewall	1	\$13.09
Xyway	1.2	\$(4.29)
Zironar Pfiefer Farms	0.5	\$(8.45)
Zironar	-0.7	\$(24.16)
Soybean Plant Date with Starter: June 6th	-1.5	\$(51.98)

Soybean Summary of 2023 Conceal® Applications

PTI Farm Study	Bu/A.	ROI\$/A
Soybean Plant Date with Starter: April 13th	9.5	\$92.02
Soybean Plant Date with Starter: May 18th	9.5	\$92.02
Soybean Plant Date with Starter: March 30th	8.2	\$75.00
Marco 14-12-4-6S 15Gal	5.5	\$56.15
Soybean Plant Date with Starter: April 24th	6.3	\$50.13
Marco 14-12-4-6S 10Gal	4.6	\$48.23
Marco 14-12-4-6S 20Gal	4.7	\$25.73
Xyway	0.8	\$(9.53)
Soybean Plant Date with Starter: June 6th	-1.5	\$(51.98)

Soybean Rolling Study

Objective: To study the yield and economic impact of rolling soybeans. A Brandt® roller (Figure 1.) was used in replicated strips at the growth stage V3.

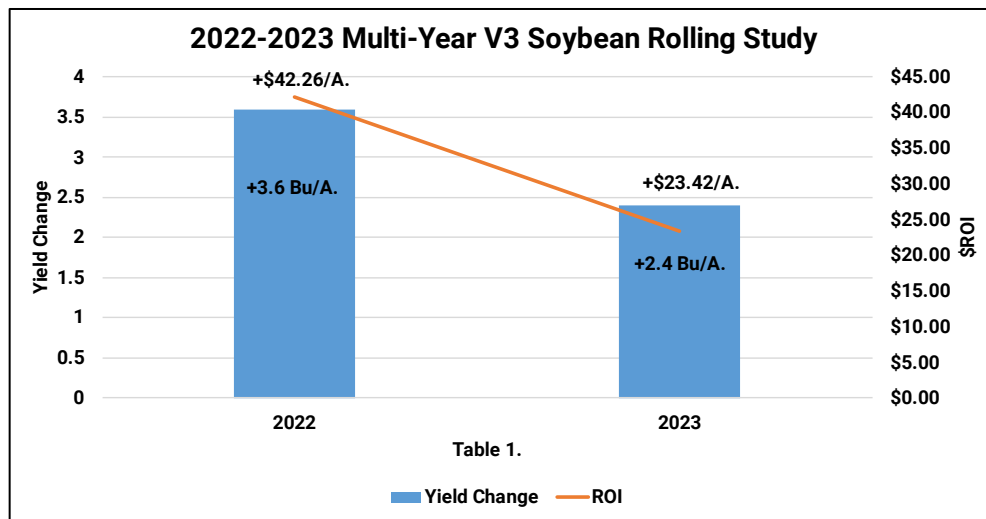
The benefits of using a roller in soybeans include the following:

- Pushing or pressing rocks into soil to avoid harvest issues
- Lays corn residue flat to aid in cleaner seed at harvest
- Stimulate reproductive growth after rolling damage occurs



Figure 1. Brandt® Roller

Results: Table 1. Illustrates multi-year soybeans rolled at the V3 growth stage resulted in yield gains of +3.6 Bu/A. in 2022 and 2.4Bu/A.in 2023. These yield advantages equated to a positive return on investment of +\$42.26/A. in 2022 and +\$23.42 in 2023.



Soybean Strip Planting Study

Objective: This study evaluates the yield and economic advantages of planting soybeans in alternate 40' and 20' strips, between corn. The PTI team first evaluated this system in 2020 to harvest more sunlight on outside rows with the intention of trying to stimulate higher corn yield. It is quite common to have higher corn yield on the outside field edges, due to corn being able to harvest more sunlight. However, most often after the first few rows this yield advantage decreases due to more shading of corn biomass.

However, to increase corn yield with this strip cropping system, soybeans are used as a “sacrificial lamb” to help introduce a sunlight

corridor as a short crop to help increase corn yield. This great for corn, but not so much for soybeans. Corn being the taller crop, competes and shades soybean rows at various times of the early morning and later evening hours (Figure 2). This study is intended to measure the associated economics of this system.

In order to understand the agronomics of this strip cropping system, we split our trial design into four segments:

- 40' Soybean Blocks (16 rows 30") planted in North/South rows
- 40' Soybean Blocks (16 rows 30") planted in East/West rows
- 20' Soybean Blocks (8 rows 30") planted in North/South rows
- 20' Soybean Blocks (8 rows 30") planted in East/West rows



Figure 1. 40' Alternate Strips of Corn and Soybeans



Figure 2. 40' North/South vs. East/West Planting Formation

Soybean Strip Planting Study Continued

Figure 3. illustrates soybean strips in a 40' or 16 row 30" block formation. These soybean blocks were planted alternatively with 30" corn in both a North to South and East to West planting row to allow the ability to study the differences in sunlight shading. In corn, we have also implemented the use of "shorter" stature corn being planted on the outside 4 rows of each 40' or 16 row blocks in an attempt to minimize shading of the soybeans from the corn.



Figure 4. illustrates soybean strip planting in a 20' or 8 row 30" block formation. These soybeans were also planted alternatively with 30" corn in both a North to South, as well as an East to West planted row to allow the ability to study the differences in sunlight shading and overall yield differences between wide and narrower soybean blocks. In the past, both "shorter" stature corn and a tall hybrid implemented in the 20' blocks, but only independently and not within the same block.

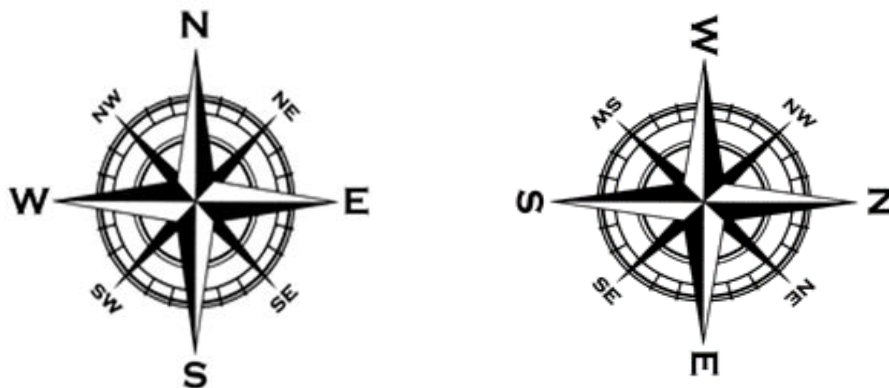


Soybean Strip Planting Study Continued

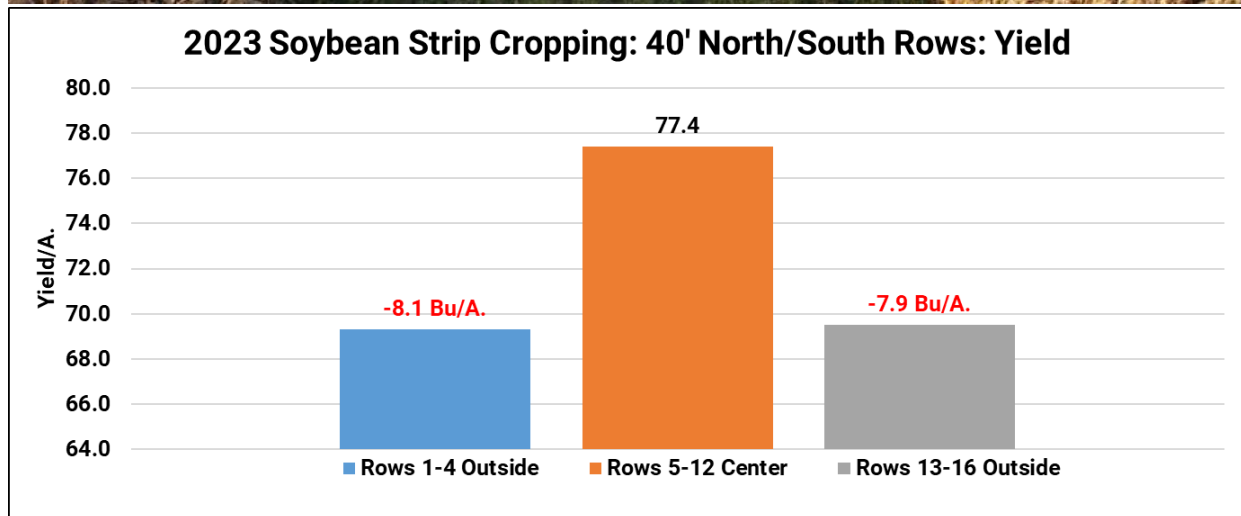
In order to understand the agronomics of the 40' or 16 row blocks, we split our 16-row planter into three individual segments to evaluate soybean yield performance:



These three individual segments were then planted in both North to South and East to West directional planting formations to evaluate the yield and economics on planter row direction.



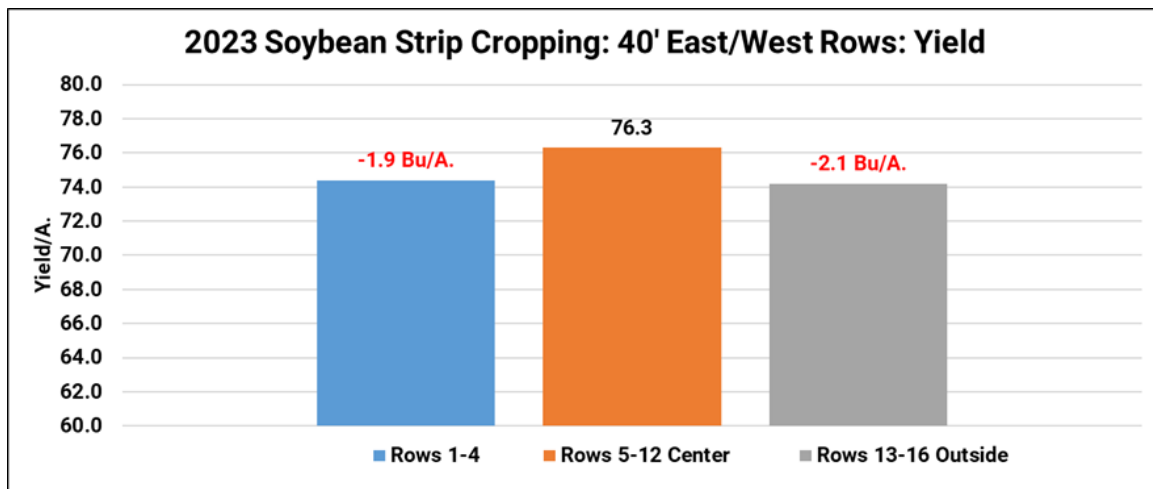
Soybean Strip Planting Study Continued



The above graph illustrates the yield response of each planter row segment in the 40' alternate strips planted in a North/South formation. Compared to the center six planter rows, the outside five rows of the planter rows 1-5 and 12-16 offered average yield losses of **-7.9 Bu/A. to -8.1 Bu/A.** Status quo full field planting would equate to 77.4 Bu/A. soybean yield (center 6 rows), while this crop stripping experiment decreased soybean yield to 69.3 Bu/A. and 69.5 Bu/A. on the "solar corridor" rows next to the corn.

Overall, north/south row strips planted in 40' (16 row) blocks offered **average** yield losses of **-8.0 Bu/A.** resulting in revenue losses of **-\$104.72/A.**

Soybean Strip Planting Study Continued

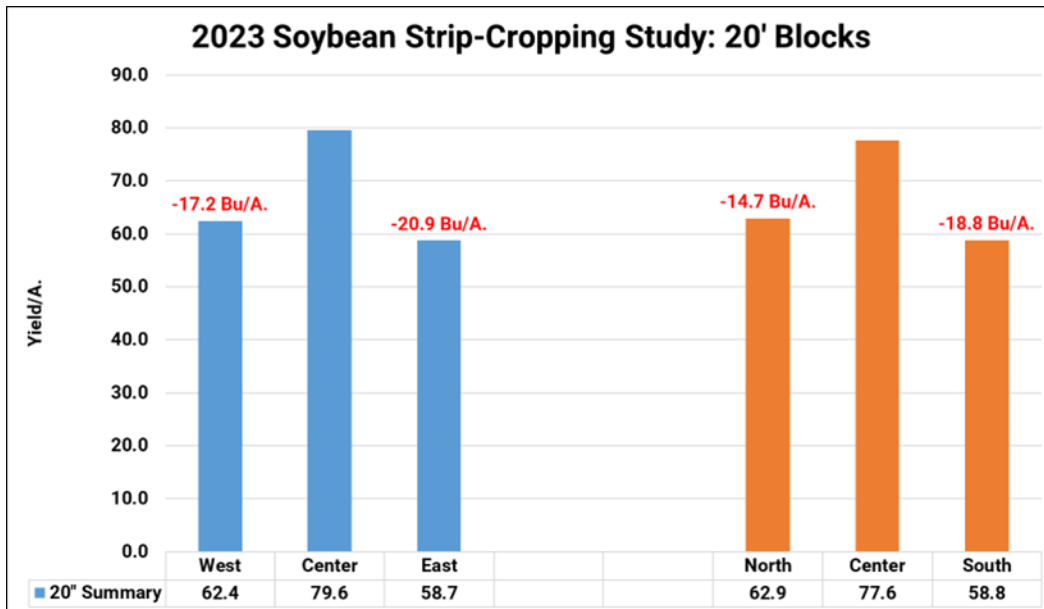


The above graph illustrates the yield response of each planter row segment in the 40' alternate strips planted in an East/West formation. Compared to the center six planter rows, the outside five rows of the planter (rows 1-5 and 12-16) offered average yield losses of **-1.9 Bu/A. to -2.1 Bu/A.** Status quo full field planting would equate to 76.3 Bu/A. soybean yield (center 6 rows), while this crop stripping experiment decreased soybean yield to 74.4 Bu/A. to 74.2 Bu/A. on the "solar corridor" rows next to the corn.

Overall, east/west row strips planted in 40' (16 row) blocks offered **average** yield losses of **-2.0 Bu/A.** resulting in revenue losses of **-\$26.18/A.,** a +78.54 Bu improvement compared to north/south planted rows.

Soybean Strip Planting Study Continued

To understand soybean yield in strips by block size, 20' (8 row) blocks were planted with a four-row planter. This smaller configuration allows for more "solar corridor" outside rows and reduces the 40' blocks to half the size. Due to the small size of the 20' strips, yield data was only harvested as a single strip.



20' blocks planted north/south offered yield losses of **-19.1 Bu/A.** and economic losses of **-\$250.02/A.**
 20' blocks planted in an east/west formation lightened the loss, but still lost **-16.8 Bu/A.** and revenue of **-\$219.91/A.**

Strip Crop Planting Summary

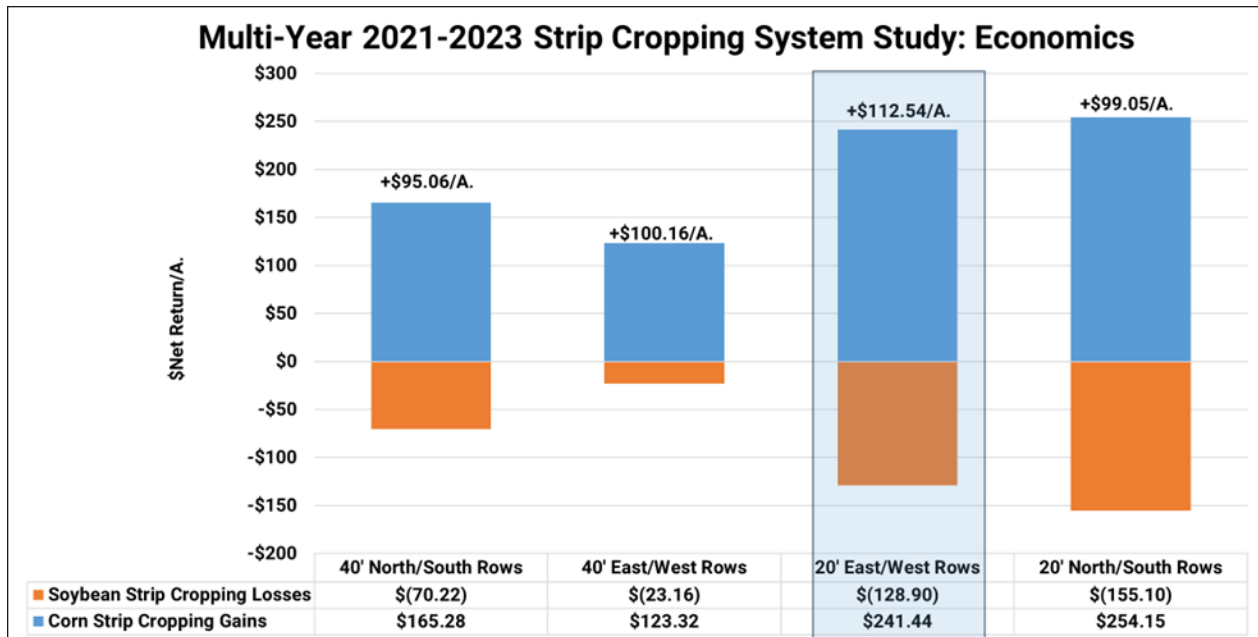
Objective: This summary evaluates the overall economic advantages of planting corn and soybeans as a system approach in alternate 40' and 20' strips.

Results: The graph below illustrates multi-year data from 2021-2023 on the overall economic gains and losses from the strip cropping system at the PTI Farm. Strip cropping as a system has proven additional returns varying from +\$95.06/A. to +\$112.54/A.



However, soybeans are the true sacrificial lamb in this cropping system. Soybeans in a strip cropping system incurred net yield and revenue loss in every block size and planting direction over the 3-yr period. Net revenue losses were realized from **-\$23.16/A.** to **-\$155.10/A.**, with the smaller 20' blocks planted north/south resulting in the highest soybean losses. For a strip-cropping system to work effectively with a short crop of soybeans next to a tall crop of corn, an east/west planting formation needs to be implemented to eliminate shading from corn.

However, even though soybeans resulted in large yield and revenue losses, it wasn't enough to negate the gains from corn. Yes, soybeans lost money, however it set the stage and allowed corn to flourish in strips. Strip-cropping in 20' blocks planted in east/west rows have dominated over the past three years and have offered the highest over economic return at +\$112.54/A.



Revytek™ Soybean Foliar Fungicide Study

Mefentrifluconazole	Group	3	Fungicide
Fluxapyroxad	Group	7	Fungicide
Pyraclostrobin	Group	11	Fungicide

Objective: To evaluate the yield and net return of a new triazole soybean fungicide introduced in 2020 called Revytek™. Revytek™ contains Revysol, which is a DeMethylation Inhibitor (DMI) fungicide that is part of the triazole group of fungicides. It was initially labeled for 17 crops, including corn and soybeans.

Revytek™ gives excellent control of frogeye leaf spot, septoria, target spot, and Asian soybean rust.

Results: Tables 1 illustrates foliar applications of Revytek™ resulted in yield gains of +3.1 Bu/A. at R1 and +4.8 Bu/A. at R3 growth stage applications. Combo R1/R3 resulted in +5.0 Bu/A. yield response.

After cost of application and fungicide, Revytek™ proved positive net returns of +\$10.58, +\$32.83, and +\$5.45/A. respectively (Table 2).



Revytek™
Fungicide

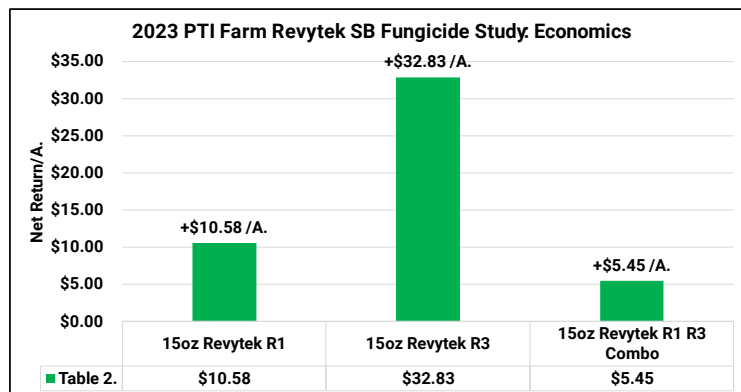
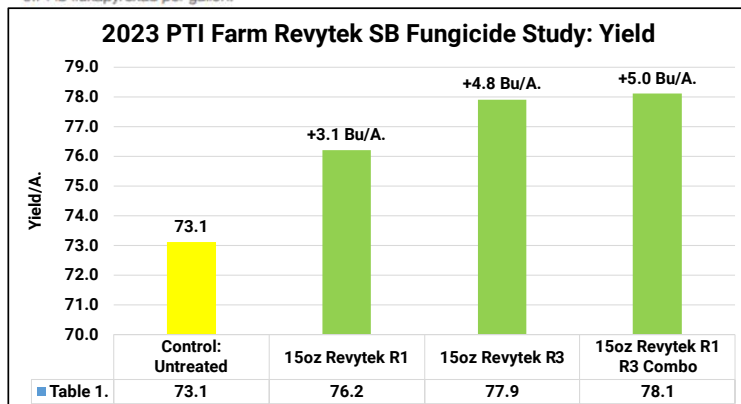


We create chemistry

Active Ingredients*:

mefentrifluconazole: 2-[4-(4-chlorophenoxy)-2-(trifluoromethyl)phenyl]-1- (1H-1,2,4-triazole-1-yl)propan-2-ol	11.61%
pyraclostrobin: (carbamic acid, [2-[[[1-(4-chlorophenyl)- 1H-pyrazol-3-yl]oxy]methyl]phenyl]methoxy-, methyl ester)	15.49%
fluxapyroxad: 1H-Pyrazole-4-carboxamide, 3-(difluoromethyl)- 1-methyl-N-(3',4',5'-trifluoro[1,1'-biphenyl]-2-yl)-	7.74%
Other Ingredients:	65.16%
Total:	100.00%

*Revytek™ fungicide contains 1.11 lbs mefentrifluconazole, 1.48 lbs pyraclostrobin, and 0.74 lb fluxapyroxad per gallon.



Planting Date: May 3rd Variety: Golden Harvest® 3724XF Population: 130K Row Width: 30" Rotation: BAC SB Price: \$13.96 Revytek+App: \$30/A.

Miravis® Neo™ Soybean Foliar Fungicide Study



Objective: To evaluate the yield and economics of a Miravis® Neo™ application in soybeans.



ADEPIDYN® Technology*

Active Ingredients:

Pydiflumetofen**	7.0%
Azoxystrobin***	9.3%
Propiconazole****	11.6%

Other Ingredients: 72.1%

Total: 100.0%

Miravis® Neo™ fungicide combines propiconazole, azoxystrobin and Adepidyn technology – one of the most powerful, broad spectrum SDHI molecules available, and delivers superior plant-health benefits and improved preventive and curative control of key such as Brown Spot, Pod and Stem Blight, Frogeye Leaf Spot, Anthracnose, Powdery Mildew and White Mold (suppression).

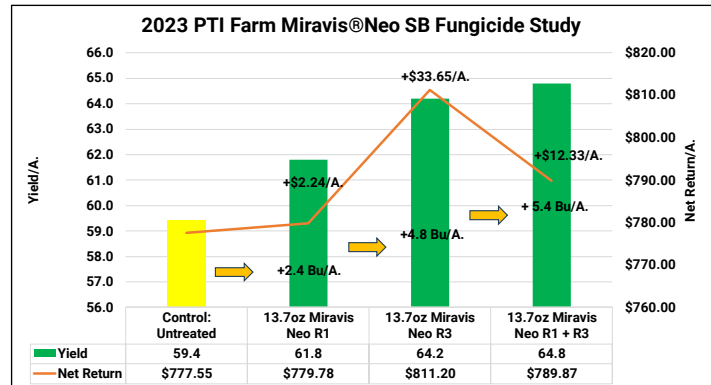


PYDIFLUMETOFEN	GROUP	7	FUNGICIDE
PROPICONAZOLE	GROUP	3	FUNGICIDE
AZOXYSTROBIN	GROUP	11	FUNGICIDE

Results: Early R1 applications of Miravis®Neo™ resulted in only +2.4 Bu/A. yield responses with economic gains at +\$2.24/A.

R3 individual treatments resulted in nice yield gains at +4.8 Bu/A. with positive economic gains of +\$33.65/A.

R1 + R3 sequential treatments achieved highest yield response at +5.4 Bu/A., however just broke even with returns of +\$12.33/A.



Fungicide Ground vs. UAV Foliar Spray Application Study

Objective: To evaluate the yield and net return of Trivapro® fungicide applied at R3 growth stage.

This study evaluates a traditional ground fungicide application with a Hagie® high-clearance sprayer, at a carrier rate of 15 Gal/A. Additionally, the use of a DJI™ AGRAS T40 spray UAV was also evaluated at carrier rates of 3 Gal/A. (Figure 1).

Trivapro® fungicide is a fungicide for corn, soybeans, and wheat. It contains three robust active ingredients including Solatenol® fungicide, azoxystrobin and propiconazole. Trivapro® is a fungicide product that offers both preventive and curative disease control.



SOLATENOL® Technology*

*Technology denotes the active ingredient, Benzovindiflupyr.

Active Ingredients:

Benzovindiflupyr** : 2.9%

Azoxystrobin*** : 10.5%

Propiconazole**** : 11.9%

Other Ingredients: 74.7%

Total: 100.0%

Figure 1. DJI™ AGRAS T40 UAV

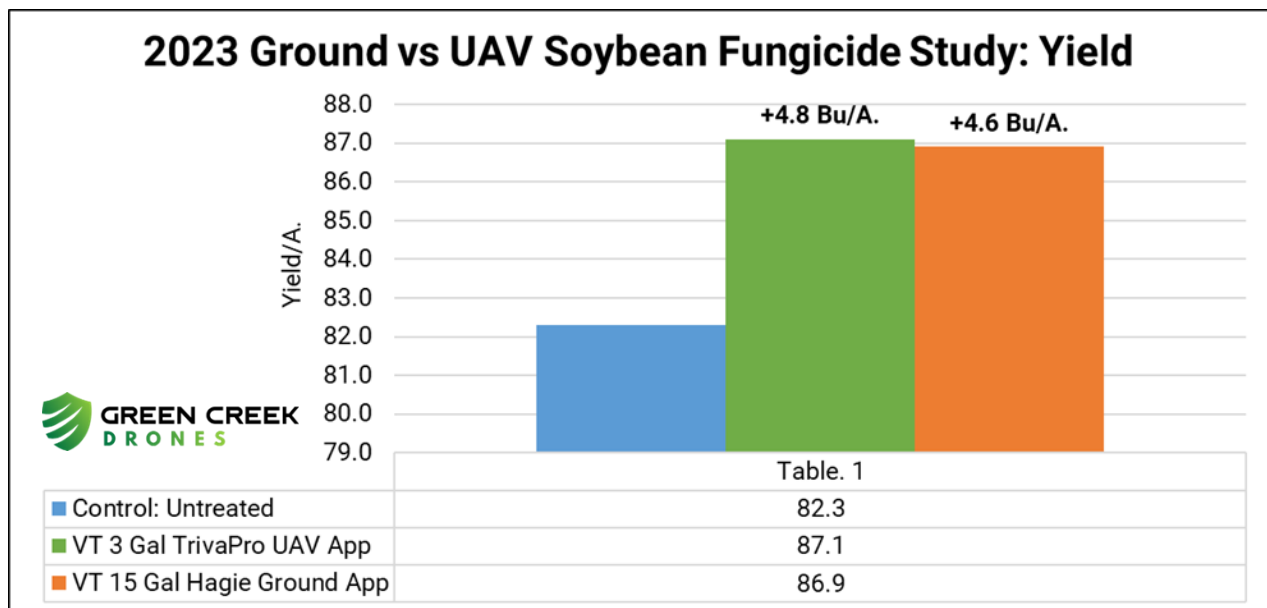


Fungicide Ground vs. UAV Spray Application Study Continued

Results: Table 1. illustrates that R3 foliar applications of Trivapro® resulted in yield gains of +4.6 to +4.8 Bu/A. The Hagie® high clearance sprayer and the T40 spray UAV offered similar yields, ranging within only 0.2 Bu/A. of each other. This yield gain equated to +\$2.62/A. additional return.

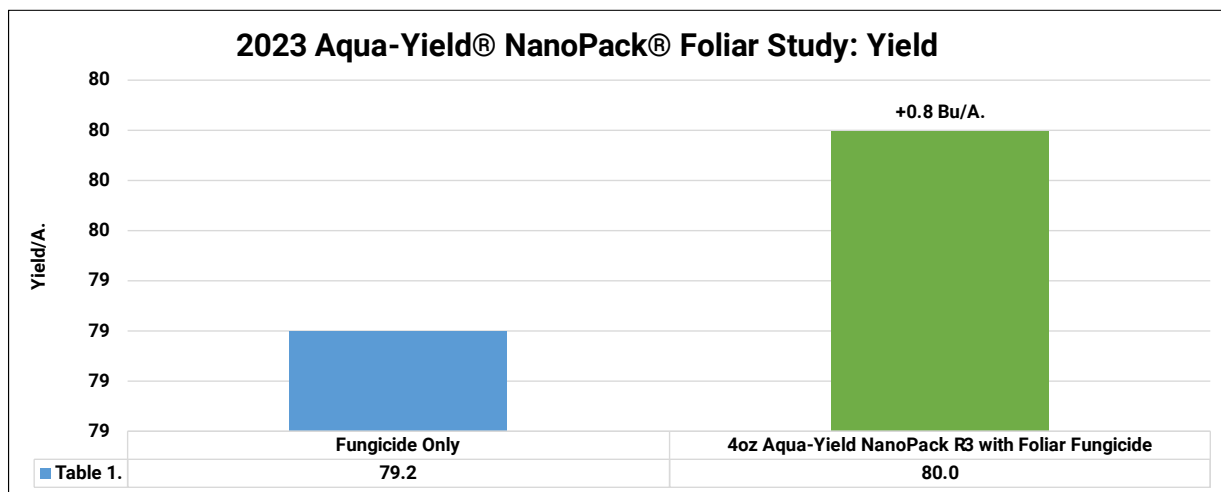
This data shows that UAV’s can provide an effective method for application of crop protection products. When used properly UAV technology can offer similar or better results than traditional ground application equipment.

Advantages to UAV technology include precise application due to downward propeller air movement, low carrier rates, the absence of ground or soil engagement, and the ability to spray in fields with topography challenges. Disadvantages include flight time duration, tank capacity, battery charge, and insurance/licensing.



Aqua-Yield® NanoPack® Foliar Study

Objective: To evaluate yield and economics of NanoPack® by AQUA-YIELD®. NanoPack® (0.5Cu-2Fe-1Mn-1Zn) is a micronutrient product that enhances crop yields and promotes plant health by delivering essential nutrients directly to the cellular level. NanoPack® delivers sulfur, copper, iron, manganese, and zinc through Aqua-Yield® nanoliquid technology. It brings critical micronutrients to plants when soil levels are low and prevents deficiencies that limit crop yield while boosting plant metabolism and overall health. Nanoliquid products effectively work as a deliver system for nutrients and protects molecules from environmental losses and delivers them them to plants at the cellular level. A process called endocytosis brings the nanoliquid particles into the cell where the payload is delivered. This trial aims to establish the efficiency of Aqua-Yield’s NanoPack® nano-liquid based fertility product in tandem with Fungicide. NanoPack® was applied at R3 in tandem with Foliar Fungicide.



AQUA-YIELD®

NanoPack®

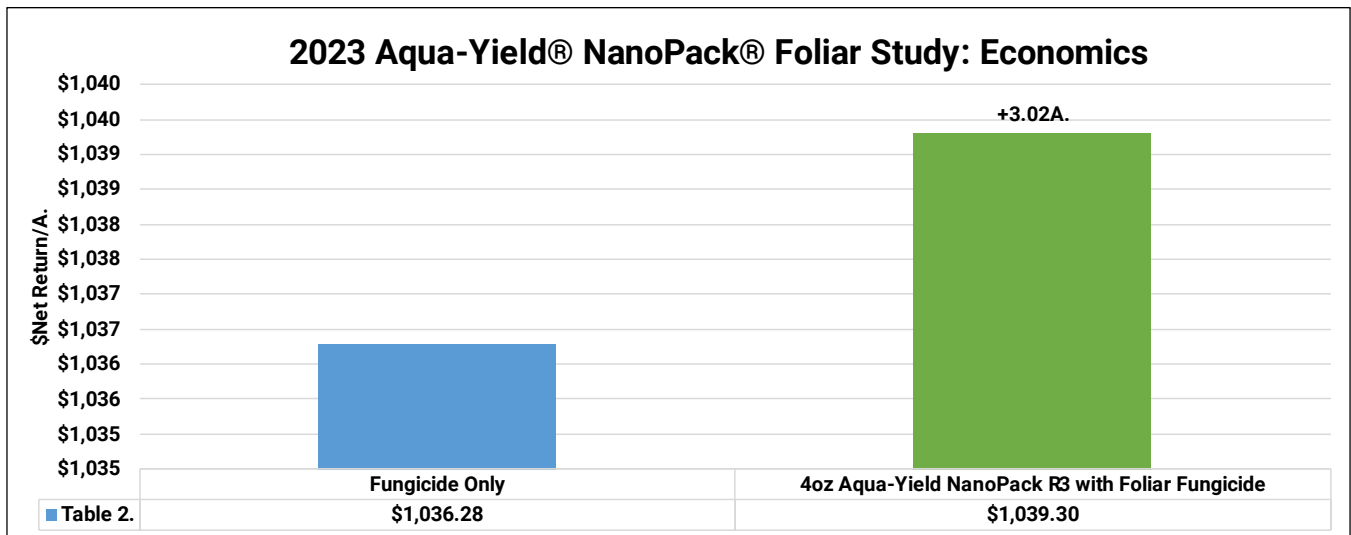
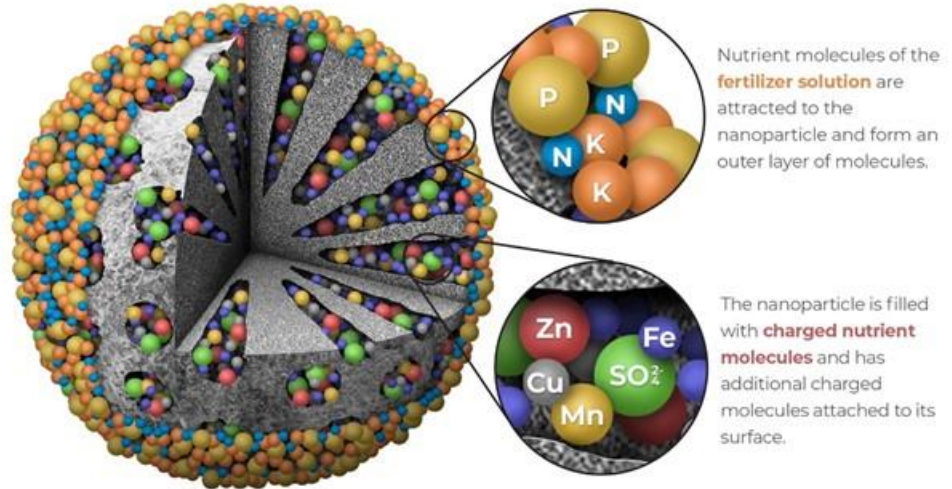
Aqua-Yield® NanoPack® Foliar Study Continued

Results: Table 1. illustrates yield results of all treatments. Aqua-Yield's NanoPack® tank-mixed with fungicide resulted in +0.8 Bu/A. yield improvement over the control.

Table 2. illustrates the overall economics of the foliar study where NanoPack® resulted in economic gains of +\$3.02/A.

THE ANATOMY OF AN Aqua-Yield® NanoPack® Particle

A **nanoparticle** is between 1-100 nanometers (nm) in size, providing room for thousands of nutrient molecules.



Soybean Tillage Study

Objective: To evaluate the yield and economic impacts of various tillage programs in a soybean after corn rotation. Tillage programs include conventional till, strip-till, vertical till, no-till and in-line rip.

Figure 1. KUHN® Krause Gladiator®



Figure 2. Sunflower® 4630 Disc



Soybean Tillage Study Continued

Figure 6. Univ. of IL Machinery Cost Estimates

Tillage Practice	Category	Cost
Conventional Till	Ripper	\$36.40
	Soil Finisher	\$14.60
	Plant	\$21.40
	Total:	\$72.40
Strip Till	Strip	\$25.90
	Burndown	\$10.00
	Plant	\$21.40
	Total:	\$57.30
Vertical Till	Vertical	\$17.60
	Burndown	\$10.00
	Plant	\$21.40
	Total:	\$49.00
No Till	Plant	\$21.40
	Burndown	\$10.00
	Total:	\$31.40
In-Line Ripper	V-Ripper	\$33.70
	Soil Finisher	\$14.60
	Plant	\$21.40
	Total:	\$69.70

Figure 4. Planting in No-Till



Figure 1. Kuhn® EXCELERATOR® XT 8010 Vertical Tillage



Figure 5. Sunflower® 4608 In-Line Ripper



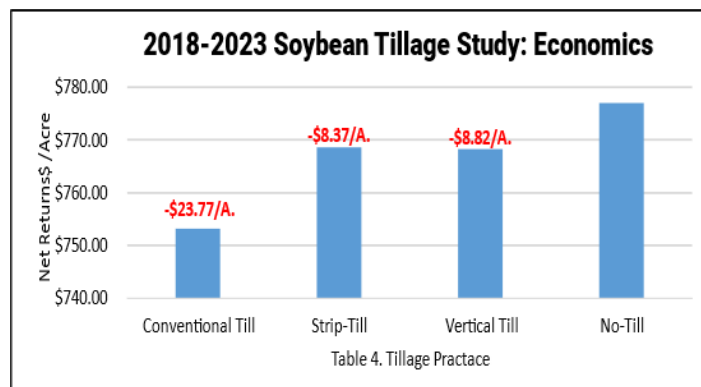
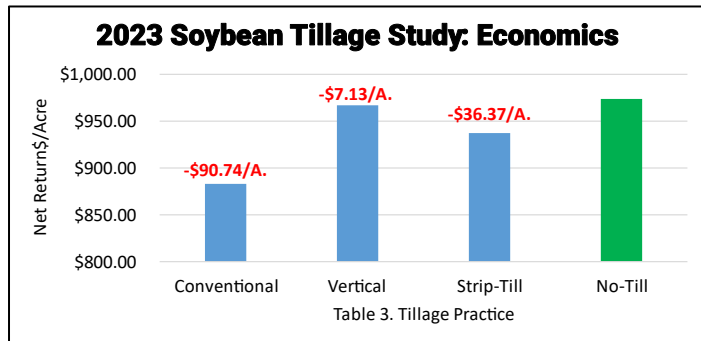
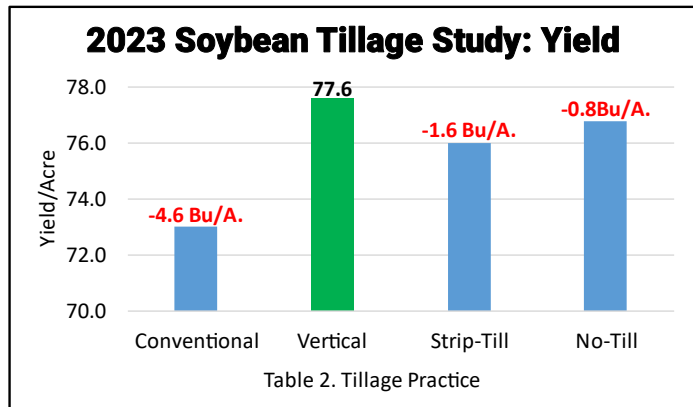
Soybean Tillage Study Continued

Results: To understand both yield and economics, the University of Illinois Machinery Cost Estimate Summary is used to calculate individual cost of each tillage program (Table 1). For the three reduced tillage programs, an extra \$10/A. burn-down is also included due to higher herbicide costs in 2023.

Table 2. illustrates the overall yield for each tillage segment. The yields varied less than 5.0 Bu/A. between all tillage programs with vertical tillage offering the highest yield of 77.6 Bu/A.

After applying all appropriate costs to each individual tillage segment, no-till offered the highest overall revenue in this tillage system study in 2023. Compared to no-till, strip-till offered losses of **-\$36.37/A.**, vertical tillage **-\$7.13/A.** and due to higher equipment cost, conventional tillage with the highest losses of **-\$90.74/A.** (Table 3.)

Table 4. illustrates multi-year data from the PTI Farm over the time period of 2018-2023. Over this time frame, no-till has provided economic gains of **+\$8.37/A.** over strip-till, **+\$23.77/A.** over conventional till and **+\$8.82/A.** over vertical tillage.



Soybean Pre-Strip Vertical Tillage Study

Objective: To evaluate the yield and economic benefit of implementing a vertical tillage (Figure 1.) in corn stalks before a fall strip-till application (Figure 2.) to aid stalk decomposition.

Results: Vertical tillage made pre-strip-till proved to be beneficial with a +0.6 Bu/A. yield contribution. As a result of the extra pass, net economic losses occurred of **-\$9.75/A.**



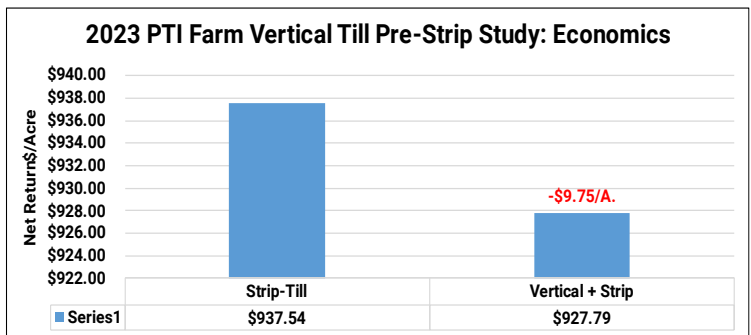
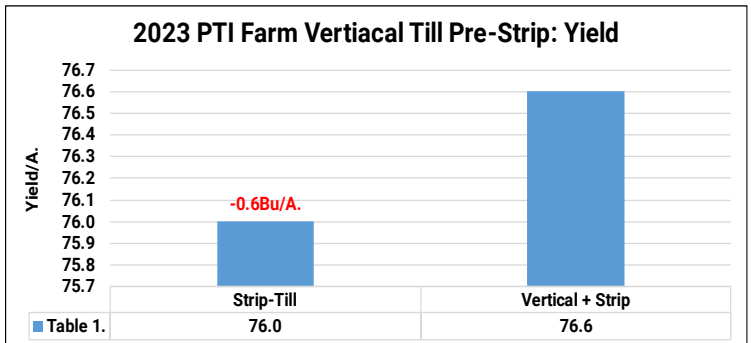
Figure 1. Kuhn® EXCELERATOR® XT 8010 Vertical Tillage Before Strip-Till



Figure 2. Kuhn® Krause Gladiator



Tillage Practice	Category	Cost
Conventional Till	Ripper	\$36.40
	Soil Finisher	\$14.60
	Plant	\$21.40
	Total:	\$72.40
Strip Till	Strip	\$25.90
	Burndown	\$10.00
	Plant	\$21.40
	Total:	\$57.30
Vertical Till	Vertical	\$17.60
	Burndown	\$10.00
	Plant	\$21.40
	Total:	\$49.00
No Till	Plant	\$21.40
	Burndown	\$10.00
	Total:	\$31.40

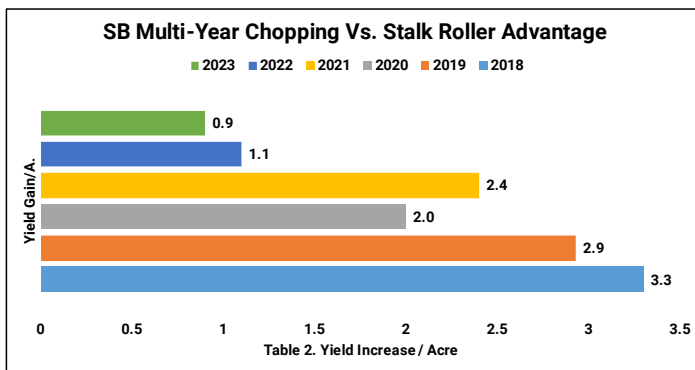


Soybeans Chopping Corn Head Study

Objective: To study the yield impact of utilizing a chopping corn head in a corn/soybean conventional tillage rotation. A Capello DIAMANT™ chopping head is used to create replicated strips of chop and non-chop residue management trials. The goal of this trial is to evaluate sizing of residue, allowing heavy stalks and residue to break down faster to advance the degradation process and in turn, reducing the carbon penalty associated with continuous corn environment.

Results: Table 1. illustrates that chopping corn residue improved soybean yields by +0.9 Bu/A. At a soybean commodity price of \$13.09/Bu, this resulted in additional gross revenue of +\$11.78/A.

Multi-year data from 2018-2023 indicates yield advantages of +0.9 to +3.3 Bu/A.



Wrap Up

Precision Planting is excited to share our 2023 PTI research farm results and findings. We hope they provide useful insights that help drive thoughtful consideration around future crop management. The PTI Farm is working diligently to continue with long-term studies that provide multi-year data analysis for decision-making purposes. We will continue to work with our Precision Planting Premier Dealers to identify opportunities to find new research objectives, driving innovation and development of new solutions in the field. Precision Planting continues to find new ways to provide commitment to the development of innovations and insights that allow for the highest yield and ROI opportunities for your farm and family.

One of our goals at the PTI Farm is to continue to bring new, fresh, and unique ideas, so that when growers visit the farm they see and experience new technology. “Challenging the Status Quo” is an important concept to us and we always want to offer the opportunity for growers to experience, compare, and challenge their traditional ways of farming to other means. We all know that change is inevitable, but knowing what and when to change is critical to a business. At the PTI farm, we are excited about all of the agronomic trials slated for 2024 and you will not want to miss our upcoming field days. We look forward to seeing you throughout July-September at the Precision Planting Precision Technology Institute at Pontiac, IL.

Precision Planting would like to extend our sincere gratitude to the support and dedication of our Precision Planting Premier Dealers. Precision Planting Premier Dealers are world-class certified precision agriculture experts, with rigorous training and knowledge of the industry and issues facing farmers today. Our Premier Dealers are experienced professionals helping you know more, and ultimately creating more yield and profitability.

The ability to provide unbiased and objective insights into the agronomic research is important to us and we appreciate all Premier Dealers who scheduled and invited growers to the farm in 2023. If you are interested in visiting the PTI Farm in 2024, please contact a Precision Planting Premier Dealer to schedule your visit to the PTI Farm. For your convenience, click here to use our Dealer Locator to find the Precision Planting Premier Dealer nearest you.

http://www.precisionplanting.com/#dealer_locator/



Premier Dealer

PRECISION TECHNOLOGY INSTITUTE

All the research summarized here, was conducted as part of multiple research plots, by a team of experienced staff at the Precision Technology Institute research farm in Pontiac, Illinois. PTI is committed to challenging the status quo, to give growers agronomic insights and the tools that can help provide improved yield and economic bottom line on your own farm.

One of the questions that you may be asking after reviewing the extensive data and results from our 2022 research plots, is why? Why implement over 100 research plots, over 400 acres, with daily on-farm visits and agronomic discussions, through this time of uncertainty and so many new unknowns. The answer is what it has always been; we must continue to challenge the status quo. We must find better, smarter, and higher return on investment solutions for the growers and their farms. Precision Planting created the Precision Technology Institute in Pontiac, Illinois to provide a place for growers to meet and learn, while providing results of research plots that illustrate the practical value of their products in real world situations. The research we are sharing is designed by Precision Planting to better understand what solutions, in combination with real-world scenarios can actually provide, both a yield and economic benefit. These are learnings that we will continue to develop, implement, study and share, to provide our growers with the tools to help improve their bottom line.

Precision Technology Institute feels the best way to serve this goal to growers is as simple as having conversations. As part of this vision of having an on-going dialogue with growers, there are many ways to become part of the learnings and findings throughout the year, including an exciting new opportunity to visit PTI's new state of the art facility.



Become an Insider

A simple way to stay informed, as well as up to date on the research we are collecting here at the PTI Farm, is to become an Insider. Subscribe to the InsidePTI weekly videos at insidepti.com for all your agronomic needs.



Come Experience Field Days at PTI

So what can you expect when attending summer field days at PTI? Whether you are a frequent visitor or looking forward to your first visit, PTI field days are a high energy, information packed, learning experience. Here are some of the one of a kind experiences you can choose to take advantage of all provided by Precision Planting at the Precision Technology Institute.

- **The Driver’s Seat**

In our 27-acre sandbox, you take the wheel. Here, we hand YOU the keys to different tractor/planter combinations and allow you to run the equipment in real time, learning more in depth about how each piece works and the technology behind it. Precision Planting Support Technicians will be co-piloting in the buddy seat at this time, to answer any questions that may come about throughout your experience.

- **Core Principles and Planting Fundamentals**

This hands-on demo is led by the Precision Planting Regional Managers walking the growers through the importance of planter maintenance and furrow creation. Growers can see in person correct and incorrect furrow creation from two different planter row units. During this time, growers can interactively measure and correct the furrow created throughout the different planting conditions.

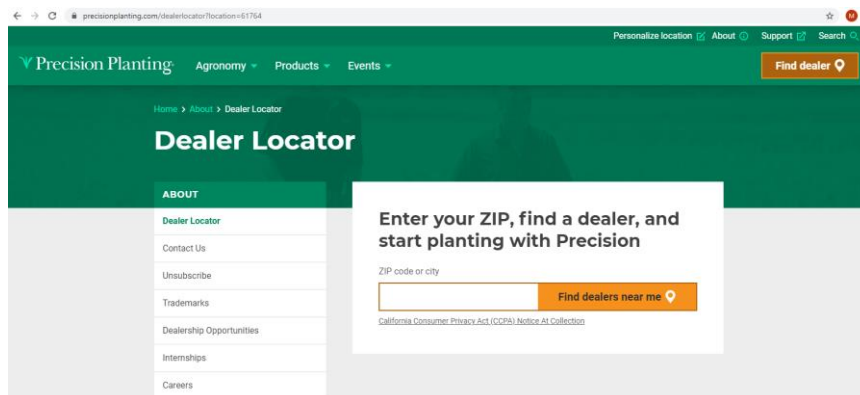
- **Agronomy Tour**

Lead Agronomist and PTI Farm Director, Jason Webster, takes you out into the field to dive deeper into the innovative agronomy and technology that we use each season throughout the different plots. You will learn about our new water recycling and tile drainage system, research tools, and technology/products available to implement on your farm.

- **Industry Days**

Each year, we invite industry partners to use PTI as an avenue to showcase their products and technology during the year. These customer focused field days are led by the industry partner’s employees. If you are interested in hosting an industry day or becoming an industry partner of Precision Planting, contact the PTI Team at ptipontiac@precisionplanting.com.

For more information regarding attendance of a PTI Field Day or Industry Day, reach out to your Precision Planting Premier Dealer or visit our website at precisionplanting.com/events to schedule a visit.



Acknowledgements and Legal Statement

vSet®, SmartFirmer®, Keeton®, CleanSweep®, SpeedTube®, DeltaForce®, vDrive®, FurrowJet®, Conceal®, mSet®, 20|20®, SmartDepth®, FurrowForce®, Reveal™, Pump Stack®, EM Flowsense™, EMHD® and WaveVision® are all Trademarks of Precision Planting, LLC. imPulse®, Triple Option®, Face Off®, K-Fuse®, Finish line®, Start2Finish®, bio-K®, Throwback®, First Down®, Rhyzo-Link®, Humi-Flex®, SideSwipe®, K-Flex® Max, Humi-Flex® FA, K-Fuel®, Balance®, Aqua Tech®, Nachurs® 10% Boron and Nachurs® 10% Molybdenum are trademarks of Nachurs Alpine Solutions. Wholeshot, Compost Tea, Macrosorb RZT, Pacific Gro, Yucca, Sea Crop, High Energy Fish, Big Shot are products of Nutrient Management Specialists LLC. Charge12%™, Harvest Plus™, Stimulant Yield Enhancer®, Sugar Mover®, Harvest More®, Bio-Forge®, Energy Power® and X-Cyte™ are trademarks of Stoller®USA. Pro-Germinator®, AccesS™, FertiRain®, Sure-K®, Springup®, Micro 500®, eNhance™, LiberateCa™, Nresponse® Kalibrate® are trademarks of AgroLiquid LLC. MicroAZ-IF Liquid™ and MicroAZ-ST Dry™ are trademarks of TerraMax Ag inc. NutriStart™, Foliar Complete, Boost and QuickGrow LTE, Poseidon, Energizer, Foliar Complete, Iron Plus are all products of Marco N.P.K. Inc. QLF™, Boost™ and Amino-15™, TripleThreatOption 5-5-5, K-Ferm 0-0-12 are trademarks of QLF™. REVLIN® HOPPER THROTTLE™ are registered trademarks of Meristem Crop Performance Group LLC. Mosaic®, Nutriform®, Aspire®, and MicroEssentials® SZ® are registered trademarks of The Mosaic Company the Andersons®, MicroMark® DG B are trademarks The Andersons, Inc. Nano-CS™, NanoN+™, NanoN™, Nano-K®, NanoPack®, Nano Pro® are trademarks of Aqua Yield operations. PhycoTerra® is a registered trademark of Heliae Development, LLC. Ascent® is a trademark of Winfield United. SeedRight BundleDrop is a registered trademark of Seed Right. STRIDEBIO® is a trademark of Rosens. Rootella® is a trademark of Groundwork BioAg. Terrasym® 450 + Dust™ + TS201™, Rizosphere, Phenom®, ionFx™, Frenzy™ are registered trademarks of NewFields Ag. Envita® is a trademark of Engage Agro Corporation. Sandy-Cal, Nutri-shield, Power Pro II, IPS 100, Sea-90™, Elevation and Aragonite are products of Ocean Blue Ag. Proven®40 and ProvN®40 OS is a trademark of Pivot Bio. NETAFIM™ is a Trademark of Netafim LLC. NutriDrip System is a product from Kurt Grimm. fCrusher and 2nd Stage Closer closing wheels are a product from Martin-till®. DJI and AGRAS are trademarks of DJI. GERMINATOR® a product of Farm Shop MFG, LLC. Sunflower®, Fendt®, and Momentum® are trademarks of AGCO. DIAMANT™ and Quasar® are trademarks of Capello Inc. KUHN®, Krause®, Excelerator® and Gladiator® are trademarks of KUHN North America Inc. Montag® is a trademark of Montag Mfg. ADI™ is a trademark of Ag Drainage Inc. Walkabout® Mother Bins is a trademark of Walkabout Mother Bin, Inc. Twister® a trademark of YETTER Manufacturing CO., INC. John Deere® and John Deere 1770 Planter are trademarks of Deere & Company. CaseIH and Case 2150S are registered trademarks of CNH Industrial N.V. Hagie® is a trademark of Hagie Manufacturing Company LLC. Treffler precision tine harrow is a product of Treffler Maschinenbau GmbH & Co. KG. NutriMax® Single Coulter, NutriMax® Double Coulter, NutriMax® Dual Delivery System, Brent® V1000 Auger Cart, NutriMax® 1400 Side-Dress Applicator are trademarks of Unverferth Manufacturing. Nitrogen Sealing Systems is a product of Nitrogen Sealing Systems. Velytma® and Revytek® are trademarks of BASF. Source™ is a trademark of Sound Agriculture. Miravis® Neo and Triva Pro® are all trademarks of Syngenta Corp. S04™ and 98G™ are trademarks of Calcium Products. Capture®, LFR®, Ethos® XB, Xyway®, Zironar™, and Top Guard® are trademarks of FMC Agricultural Solutions. Brandt® Auger Cart 820XT and Brandt 51' Land Roller are trademarks of Brandt®. Renegade® and iControl™ is a trademark of Summers Manufacturing, Inc. Case IH® and Early Riser® 2150 are trademarks of CNH Industrial America LLC. Harvest International® Ultra™ Series 40 20" planter is a trademark of Harvest International. Pioneer® is a Trademark of Pioneer Hi-Bred International Inc. ProHarvest Seeds® is a trademark of ProHarvest Seeds. Dekalb® and Asgrow®, are trademarks of Monsanto Technology, LLC. Golden Harvest® is a trademark of Syngenta Corp. Integra Fortified Seed™ is a registered trademark of Wilbur-Ellis. WYFFELS HYBRIDS® is a registered trademark of Wyffels Hybrids. Channel® and BAYER® are registered trademarks of Bayer AG.

The University of Illinois Machinery Cost Estimates provided by The University of Illinois Farm Business
The Iowa State University Tillage Rate provided by the Iowa State University Extension and Outreach.